

# SUMMARY OF QUANTITIES

CONSTRUCTION CODE: 1000

| ROUTE                     | SECTION        | COUNTY | Total Sheets | Sheet No. |
|---------------------------|----------------|--------|--------------|-----------|
| FAS 450                   | 03-00125-00-RS | WARREN | 3            | 2         |
| PROJECT NO. RS - 450(109) |                |        |              |           |

CONTRACT NO. 89388

## ENTRANCE DETAIL

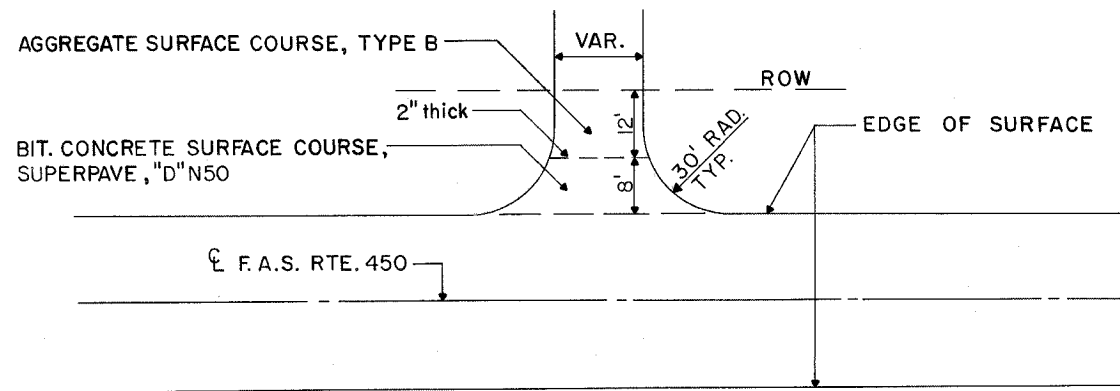

18 ENTRANCES AT 5 TONS = 90 TONS AGG. SURF. CSE., TY. B  
 18 ENTRANCES AT 5 TONS = 90 TONS SUPERPAVE, "D" N50  
 4 MAILBOX TURNOUTS AT 3 TONS = 12 TONS SUPERPAVE, "D" N50

## PAVEMENT DESIGN DATA

### PCC PAVEMENT SECTION

S.D.T. (2014) 1083 v.p.d. 15 Yr D.P.  
 T.F. 0.500  
 SN 2.87  
 IBV 2.0  
 (P.V. 95%, S.U. 3.5%, M.U. 1.5%)

### BITUMINOUS SECTION

S.D.T. (2014) 1083 v.p.d. 15 Yr D.P.  
 T.F. 0.080  
 SN 3.15  
 IBV 2.0  
 (P.V. 95%, S.U. 3.5%, M.U. 1.5%)

| CODE NO.  | ITEM  | UNIT    | QUANT.   |
|-----------|---|---------|----------|
| 40200800  | AGGREGATE SURFACE COURSE, TYPE B                            | TON     | 90.0     |
| 40600100  | BITUMINOUS MATERIALS (PRIME COAT)                           | GALS.   | 2,148.0  |
| 40600300  | AGGREGATE (PRIME COAT)                                      | TON     | 79.0     |
| 48101200  | AGGREGATE SHOULDERS, TYPE B                                 | TON     | 912.0    |
| 63000005* | STEEL PLATE BEAM GUARDRAIL, TYPE B                          | FOOT    | 2,812.5  |
| 63200710  | STEEL PLATE BEAM GUARDRAIL REMOVAL, TYPE A                  | FOOT    | 1,900.0  |
| 70101700  | TRAFFIC CONTROL AND PROTECTION                              | L. SUM  | 1.0      |
| 70300100  | SHORT-TERM PAVEMENT MARKING                                 | FOOT    | 2,713.0  |
| 70301000  | WORK ZONE PAVEMENT MARKING REMOVAL                          | SQ. FT. | 905.0    |
| 78008210* | POLYUREA PAVEMENT MARKING, TYPE 1 - LINE 4"                 | FOOT    | 37,841.0 |
| LR631020* | TRAFFIC BARRIER TERMINAL, TYPE 1                            | EACH    | 10.0     |
| X4066424  | BITUMINOUS CONCRETE SURFACE COURSE, SUPERPAVE, MIX "D", N50 | TON     | 2,971.0  |
| X4066765  | LEVELING BINDER (MACHINE METHOD), SUPERPAVE, N50            | TON     | 2,005.0  |
| X4080020  | INCIDENTAL BITUMINOUS SURFACING, SUPERPAVE, N50             | TON     | 142.0    |
| XX000405  | BUTT JOINTS, SPECIAL  | SQ. YD. | 294.0    |
| 67100100  | MOBILIZATION  | L. SUM  | 1.0      |

### Rate of application for Prime Coat

On Existing Pavement: 0.05 Gal/Sq. Yd.  
 On Cold Milled Surface: 0.10 gals./sq. yd.  
 On New Binder: 0.03 Gal/Sq. Yd.

### Rate of application for Aggregate (Prime Coat)

On Existing Pavement: 4 lbs./sq. yd.  
 On Cold Milled Surface: 4 lbs./sq. yd.  
 On New Binder: 2 lbs./sq. yd.

### BITUMINOUS MIXTURE REQUIREMENTS

| Mixture Use(s)      | Surface Course | Leveling Binder |
|---------------------|----------------|-----------------|
| AC/PG               | 64-22          | 64-22           |
| RAP%                | 15%            | 15%             |
| Design Air Voids    | 4.2% @ N = 50  | 4.2% @ N = 50   |
| Mixture Composition | IL 9.5         | IL 9.5          |
| Friction Aggregate  | Mixture "D"    | N/A             |

### Steel Plate Beam Guardrail Stations

| Left                | to | Right    | Total Feet    |
|---------------------|----|----------|---------------|
| 19+06.25            | to | 23+43.75 | 437.5         |
| 42+91.5             | to | 51+66.5  | 875.0         |
| 45+17               | to | 53+04.5  | 787.5         |
| 85+81               | to | 89+93.5  | 412.5         |
| 85+41               | to | 88+41    | 300.0         |
| <b>TOTAL LENGTH</b> |    |          | <b>2812.5</b> |

### Traffic Barrier Terminal, Type 1 Stations

|       |          |    |          |
|-------|----------|----|----------|
| Left  | 18+81.25 | to | 19+06.25 |
| Left  | 23+43.75 | to | 23+68.75 |
| Right | 42+66.5  | to | 42+91.5  |
| Right | 51+66.5  | to | 51+91.5  |
| Left  | 44+92    | to | 45+17    |
| Left  | 53+04.5  | to | 53+29.5  |
| Left  | 85+56    | to | 85+81    |
| Left  | 89+93.5  | to | 90+18.5  |
| Right | 85+16    | to | 85+41    |
| Right | 88+41    | to | 88+66    |

### POLYUREA PAVEMENT MARKING BREAKDOWN

|                        |                    |
|------------------------|--------------------|
| 4" Yellow - Centerline | 16,436 Feet        |
| 4" White - Edge Stripe | 21,405 Feet        |
| <b>TOTAL</b>           | <b>37,841 Feet</b> |

\* SPECIALTY ITEMS

## BUTT JOINT DETAIL

Stations  
 0 + 00  
 108 + 50

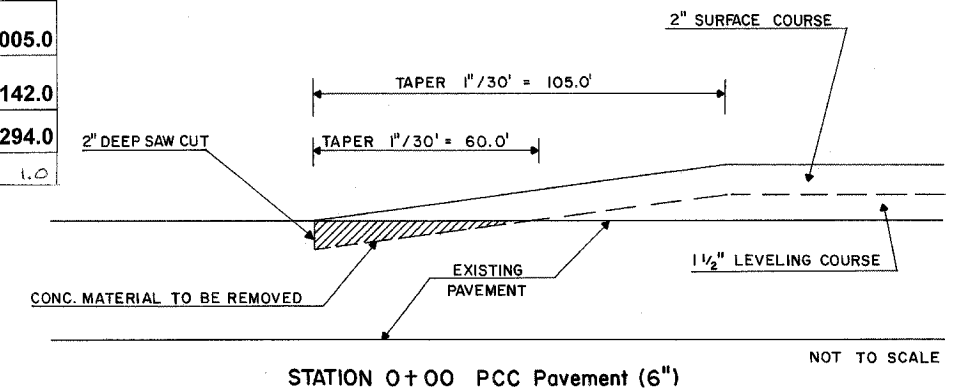

## INTERSECTION DETAIL

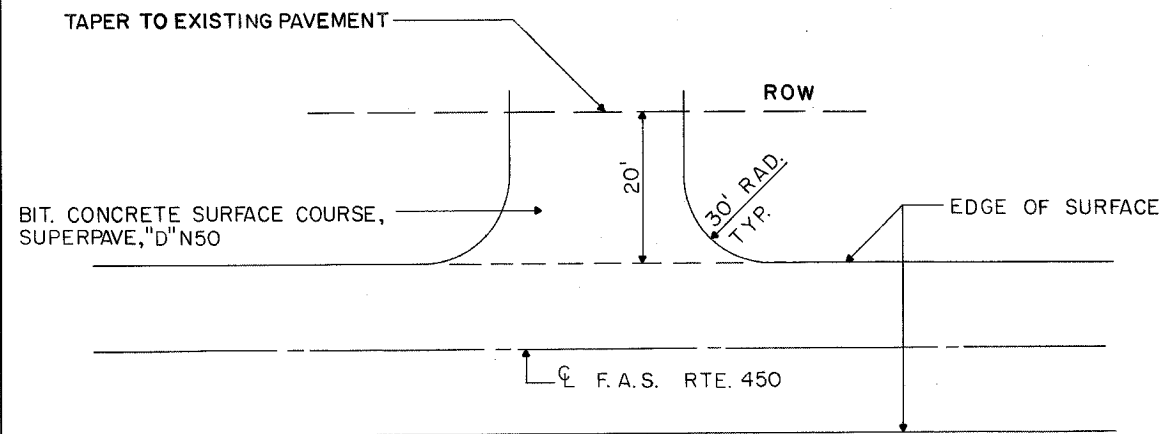

4 INTERSECTIONS AT 10 TONS  
 TOTAL = 40 TONS

