

ELEVATION

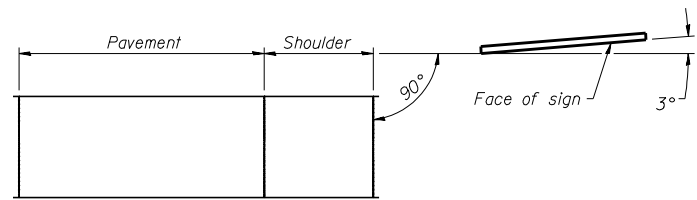

LOCATION SKETCH

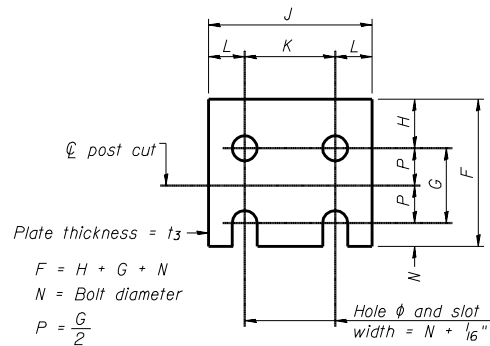

FUSE PLATE DETAIL  
(Install with notches down.)

FUSE PLATE DATA		
N = Bolt Diameter	G	H
1/2"	2"	1 1/8"
5/8"	2 1/4"	1 1/4"
3/4"	2 1/2"	1 3/8"
7/8"	2 3/4"	1 1/2"
1"	3"	1 5/8"
1 1/8"	3 1/4"	1 3/4"

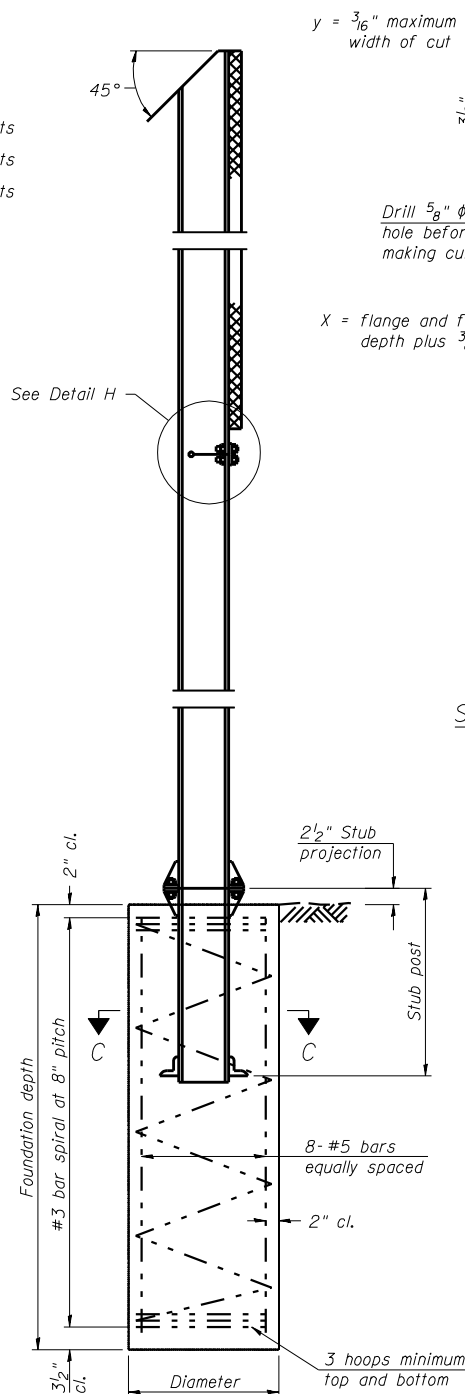

SECTION D-D

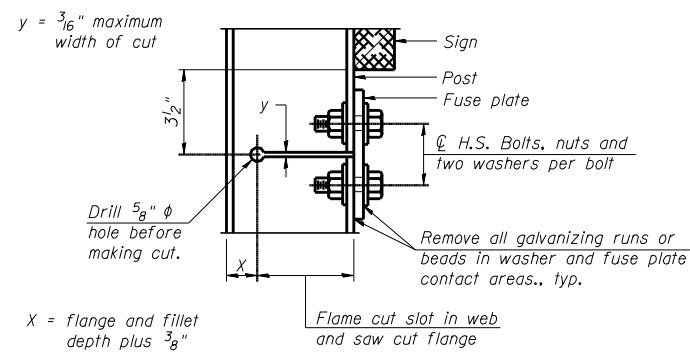

DETAIL H

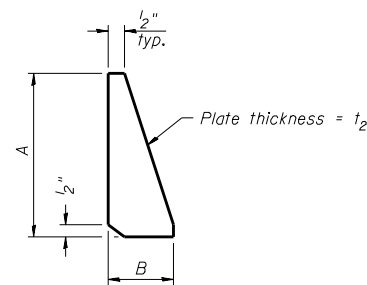

STIFFENER PLATE DETAIL  
(See table for dimensions.)

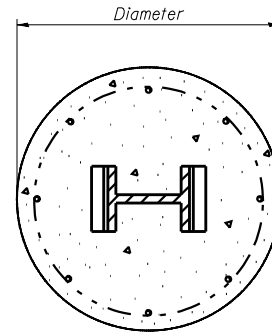

SECTION C-C

GENERAL NOTES

Posts shall be plumbed by using shims with post-to-stub post connection bolts snug tight only. Final tightening of all High Strength Bolts shall be in accordance with Article 505.04(f)(3), and threads at the junction of the bolt and nut shall be burred or center punched to prevent the nut from loosening.

LOADING: 80 m.p.h. wind with 30% gust factor, normal to sign.

DESIGN STRESSES:  
Structural steel - 20,000 p.s.i.  
Reinforcing steel - 20,000 p.s.i.  
Concrete - 1,400 p.s.i.  
Footing soil pressure - 2,000 p.s.f.

After fabrication, the post, fuse plate and upper 6", min. of the stub post shall be hot-dip galvanized in accordance with AASHTO M111. All bolts, nuts and washers shall be hot-dip galvanized in accordance with AASHTO M232.

Work this sheet with Base Sheet BAW-A-2.

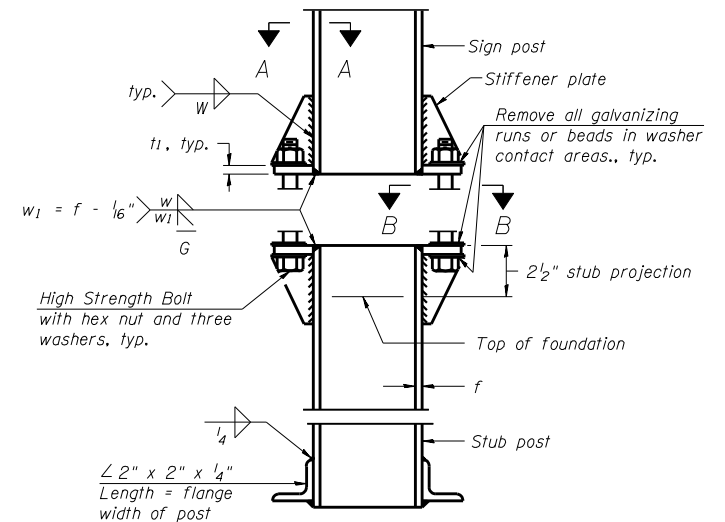

ELEVATION  
SIGN POST & STUB POST

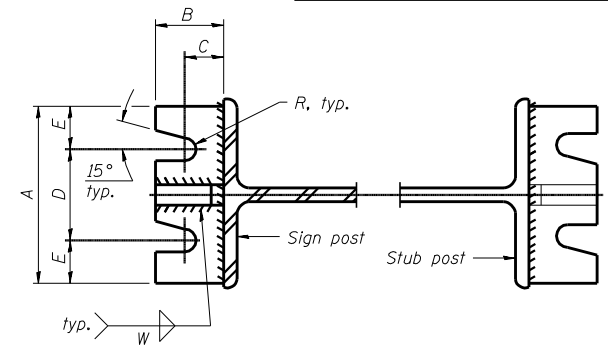

SECTION A-A

SECTION B-B

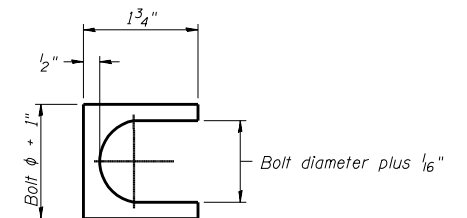

SHIM DETAIL

Furnish two 0.01" thick and two 0.03" thick stainless steel or brass (ASTM B36) shims per post.

BREAK-AWAY WIDE FLANGE  
STEEL SIGN POST DETAILS

DETAIL SHEET  
F.A.I. ROUTE. 57  
SECTION 10-32HB-3,K  
CHAMPAIGN COUNTY  
CONTRACT NO. 90758

NUMBER	REVISION	DATE