

CONTRACT NO. 97279

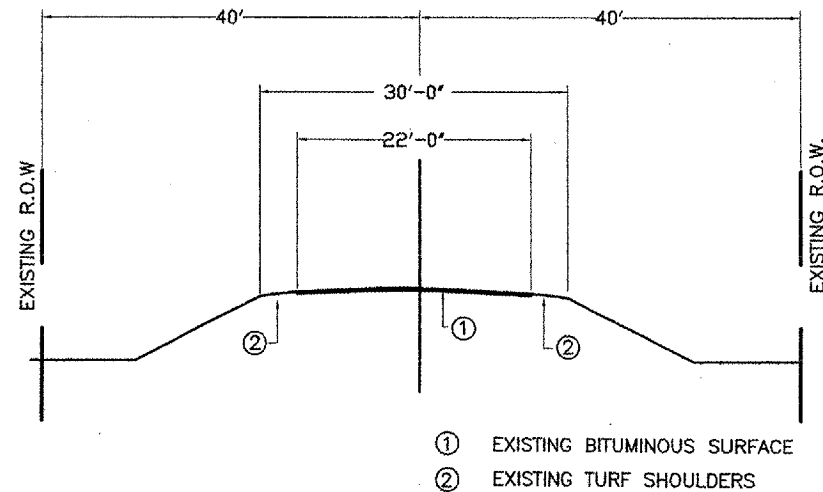

EXISTING TYPICAL SECTION

STA. 26+60 TO STA. 27+60.25
STA. 29+11.75 TO STA. 29+56.07

SCALE: 1"=10'

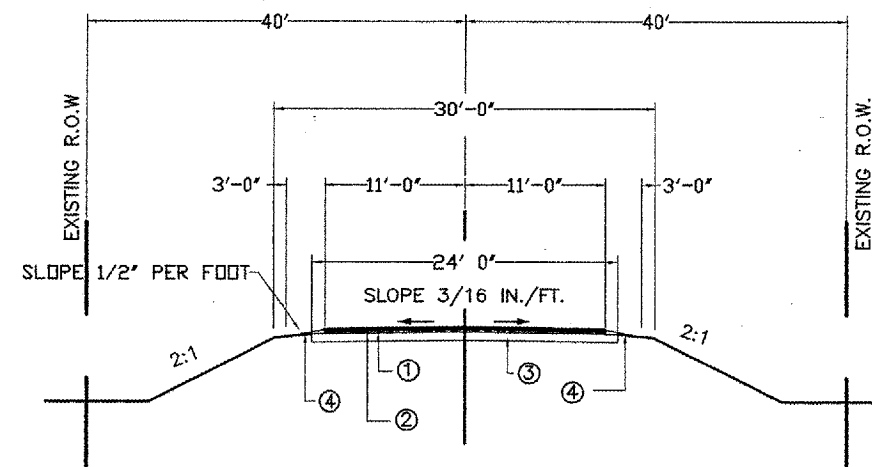

- ① Proposed 2" Bituminous Concrete Surface Course, Superpave, Mix "C", N50
- ② Proposed 2 1/2" Bituminous Concrete Binder Course, Superpave, IL-19.0, N50
- ③ Proposed 10" Aggregate Base Course, Type A
- ④ Proposed Aggregate Wedge Shoulder

PROPOSED TYPICAL SECTION

STA. 26+60 TO STA. 27+60.25
STA. 29+11.75 TO STA. 29+56.07

QUANTITIES USED FOR ESTIMATING

BITUMINOUS MATERIALS (PRIME COAT)

0.3 GAL/SQ.YD. (AGGREGATE BASE)
0.05 GAL/SQ.YD. (BITUMINOUS SURFACE)

SUMMARY OF QUANTITIES

BRIDGE CONSTR CODE - X081-2A

Quantity	Unit	Item	Item Number
50	TON	POROUS GRANULAR EMBANKMENT	20700110
204	TON	STONE DUMPED RIPRAP CLASS A4	28100807
22	TON	AGGREGATE BASE COURSE, TYPE A	35100100
18	GALLON	BITUMINOUS MATERIAL (PRIME COAT)	40600100
1	L SUM	REMOVAL OF EXISTING STRUCTURES	50100200
38	CU YD	CONCRETE STRUCTURES	50300225
4200	SQ FT	PRECAST PRESTRESSED CONCRETE DECK BEAMS (27" DEPTH)	50400505
4340	POUND	REINFORCEMENT BARS	50800105
300	FOOT	STEEL BRIDGE RAIL, TYPE SM	50901005
1591	FOOT	FURNISHING STEEL PILES HP10X42	51201400
1591	FOOT	DRIVING STEEL PILES	51202700
2	EACH	TEST PILE STEEL HP10X42	51203400
14.4	CU YD	CONCRETE ENCASEMENT	51204315
1	EACH	NAME PLATES	51500100
467	SQ YD	WATERPROOFING MEMBRANE SYSTEM	58100200
900	FOOT	PORTLAND CEMENT MORTAR FAIRING COURSE	58300100
4	EACH	REMOVE AND RE-ERECT TRAFFIC BARRIER TERMINAL, TYPE 1A	63301995
4	EACH	REMOVE AND SALVAGE Existing TRAFFIC BARRIER TERMINAL, TYPE 5A	63303700*
1	L SUM	MOBILIZATION	67100100
4	EACH	TERMINAL MARKER-DIRECT APPLIED	78201000
81	TON	BITUMINOUS CONCRETE SURFACE COURSE, SUPERPAVE, MIX "C", N50	X4066414
25	TON	BITUMINOUS CONCRETE BINDER COURSE, SUPERPAVE, IL-19.0, N50	X4066614
1	EACH	STRUCTURE EXCAVATION PROTECTION FOR PILE BENTS NO. 1	X5020301
1	EACH	STRUCTURE EXCAVATION PROTECTION FOR PILE BENTS NO. 2	X5020302
4	EACH	TRAFFIC BARRIER TERMINAL, TYPE 6A	63100087*

GENERAL NOTES

1. All advance warning signs shall be 48 in. Fluorescent Orange.
2. Pavement Marking to be done by others.

*Revised 5-25-06