

**STATE OF ILLINOIS**  
**DEPARTMENT OF TRANSPORTATION**  
**DIVISION OF HIGHWAYS**  
**PROPOSED**  
**HIGHWAY PLANS**

FOR INDEX OF SHEETS, SEE SHEET NO.2

ADT = 1,400 (2021)

**FAP ROUTE 821 (IL 15)**  
**SECTION (18BY)B**  
**PROJECT NHPP-0JVC(360)**  
**BRIDGE REPLACEMENT**  
**WAYNE COUNTY**  
**C-97-018-14**

F.A.P. RTE.	SECTION	COUNTY	TOTAL SHEETS	SHEET NO.
821	(18BY)B	WAYNE	53	1
		ILLINOIS	CONTRACT NO. 74651	

**D-97-010-14**

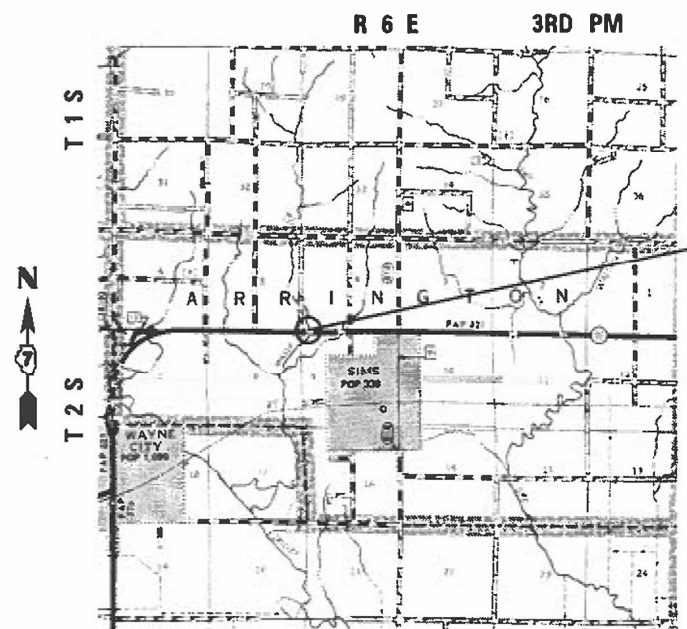
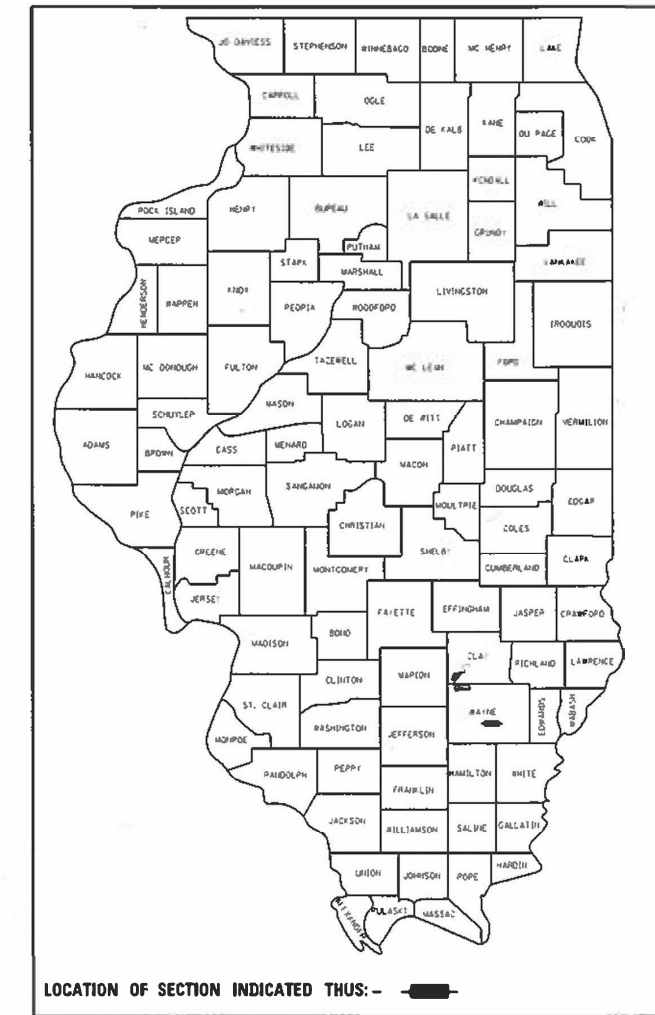

**PROPOSED STRUCTURE REPLACEMENT**  
**EX SN 096-0005**  
**PR SN 096-0076**

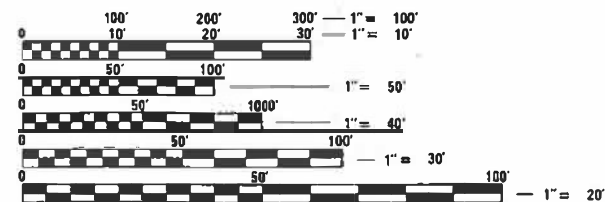

FULL SIZE PLANS HAVE BEEN PREPARED USING STANDARD ENGINEERING SCALES. REDUCED SIZED PLANS WILL NOT CONFORM TO STANDARD SCALES. IN MAKING MEASUREMENTS ON REDUCED PLANS, THE ABOVE SCALES MAY BE USED.

J.U.L.I.E.  
 JOINT UTILITY LOCATION INFORMATION FOR EXCAVATION  
 1-800-992-0123  
 OR 811

NET LENGTH OF IMPROVEMENT = 200.00 FEET = 0.038 MILES

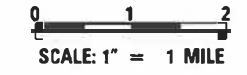

**PROJECT ENGINEER: MATT BOWER**  
**PROJECT MANAGER: KELLEN KOCHER**  
 217-342-8241  
**CONTRACT NO. 74651**

STATE OF ILLINOIS  
 DEPARTMENT OF TRANSPORTATION

SUBMITTED March 27 2023  
Jeffrey P. Myer REGIONAL ENGINEER  
 May 12, 2023 [Signature]  
 ENGINEER OF DESIGN AND ENVIRONMENT

May 12, 2023 [Signature]  
 DIRECTOR OF HIGHWAYS PROJECT IMPLEMENTATION

**PRINTED BY THE AUTHORITY OF THE STATE OF ILLINOIS**



80% FED  
20% STATE

80% FED  
20% STATE

SUMMARY OF QUANTITIES			TOTAL QUANTITIES	CONSTRUCTION TYPE CODE		
CODE NO	ITEM	UNIT		0010		
20200100	EARTH EXCAVATION	CU YD	50	50		
20300100	CHANNEL EXCAVATION	CU YD	488	488		
20400800	FURNISHED EXCAVATION	CU YD	121	121		
21101505	TOPSOIL EXCAVATION AND PLACEMENT	CU YD	235	235		
28000250	TEMPORARY EROSION CONTROL SEEDING	POUND	45	45		
28000305	TEMPORARY DITCH CHECKS	FOOT	45	45		
28000400	PERIMETER EROSION BARRIER	FOOT	1327	1327		
28100109	STONE RIPRAP, CLASS A5	SO YD	748	748		
28200200	FILTER FABRIC	SO YD	748	748		
35600724	HOT-MIX ASPHALT BASE COURSE WIDENING, 12"	SO YD	532	532		
40600290	BITUMINOUS MATERIALS (TACK COAT)	POUND	1784	1784		
40600990	TEMPORARY RAMP	SO YD	345	345		
40603085	HOT-MIX ASPHALT BINDER COURSE, IL-19.0, N70	TON	483	483		
40604052	HOT-MIX ASPHALT SURFACE COURSE, IL-9.5, MIX "C", N70	TON	187	187		

SUMMARY OF QUANTITIES			TOTAL QUANTITIES	CONSTRUCTION TYPE CODE		
CODE NO	ITEM	UNIT		0010		
40800050	INCIDENTAL HOT-MIX ASPHALT SURFACING	TON	3	3		
42000070	PAVEMENT CONNECTOR (HMA) FOR BRIDGE APPROACH SLAB	SO YD	80	80		
44000100	PAVEMENT REMOVAL	SO YD	193	193		
44004250	PAVED SHOULDER REMOVAL	SO YD	296	296		
48101500	AGGREGATE SHOULDERS, TYPE B 6"	SO YD	279	279		
48203029	HOT-MIX ASPHALT SHOULDERS, 8"	SO YD	179	179		
50100100	REMOVAL OF EXISTING STRUCTURES	EACH	1	1		
50200100	STRUCTURE EXCAVATION	CU YD	134	134		
50200300	COFFERDAM EXCAVATION	CU YD	96	96		
50201101	COFFERDAM (TYPE 1) (LOCATION - 1)	EACH	1	1		
50300100	FLOOR DRAINS	EACH	8	8		
50300225	CONCRETE STRUCTURES	CU YD	104.9	104.9		
50300255	CONCRETE SUPERSTRUCTURE	CU YD	188.3	188.3		

REV. - MS

MODEL: Default  
 FILE: \\pwwildcat-pw-bentley.com\PW\DOT\Documents\DOT\_Offices\District\_7\Projects\74651\CAD\Drawings\CAD\Drawings\74651-SPH-S00.dgn

USER NAME = Jessica.Hille	DESIGNED -	REVISED -
PLOT SCALE = 100.0000' / in.	DRAWN -	REVISED -
PLOT DATE = 3/29/2023	CHECKED -	REVISED -
	DATE -	REVISED -

STATE OF ILLINOIS  
DEPARTMENT OF TRANSPORTATION

SUMMARY OF  
QUANTITIES

SCALE: SHEET 1 OF 3 SHEETS STA. TO STA.

F.A.P. RTE.	SECTION	COUNTY	TOTAL SHEETS	SHEET NO.
821	(18BY)B	WAYNE	53	3
CONTRACT NO. 74651				
ILLINOIS FED. AID PROJECT				

80% FED  
20% STATE

80% FED  
20% STATE

SUMMARY OF QUANTITIES			TOTAL QUANTITIES	CONSTRUCTION TYPE CODE		
CODE NO	ITEM	UNIT		0010		
50300260	BRIDGE DECK GROOVING	SO YD	499	499		
50300300	PROTECTIVE COAT	SO YD	626	626		
50301350	CONCRETE SUPERSTRUCTURE ( APPROACH SLAB)	CU YD	105.9	105.9		
50800205	REINFORCEMENT BARS, EPOXY COATED	POUND	104160	104160		
50800515	BAR SPLICERS	EACH	542	542		
51201900	FURNISHING STEEL PILES HP14X89	FOOT	1044	1044		
51202305	DRIVING PILES	FOOT	1044	1044		
51500100	NAME PLATES	EACH	1	1		
52200010	TEMPORARY SHEET PILING	SO FT	1062	1062		
58600101	GRANULAR BACKFILL FOR STRUCTURES	CU YD	68	68		
59100100	GEOCOMPOSITE WALL DRAIN	SO YD	47	47		
60100060	CONCRETE HEADWALLS FOR PIPE DRAINS	EACH	4	4		
60146304	PIPE UNDERDRAINS FOR STRUCTURES 4"	FOOT	128	128		
* 63000001	STEEL PLATE BEAM GUARDRAIL, TYPE A, 6 FOOT POSTS	FOOT	159	159		

SUMMARY OF QUANTITIES			TOTAL QUANTITIES	CONSTRUCTION TYPE CODE		
CODE NO	ITEM	UNIT		0010		
* 63100085	TRAFFIC BARRIER TERMINAL, TYPE 6	EACH	4	4		
* 63100167	TRAFFIC BARRIER TERMINAL, TYPE 1 (SPECIAL) TANGENT	EACH	4	4		
63200310	GUARDRAIL REMOVAL	FOOT	330	330		
64200108	SHOULDER RUMBLE STRIPS, 8 INCH	FOOT	1352	1352		
67000400	ENGINEER'S FIELD OFFICE, TYPE A	CAL MO	6	6		
67100100	MOBILIZATION	LSUM	1	1		
70100405	TRAFFIC CONTROL AND PROTECTION, STANDARD 701321	EACH	1	1		
70100450	TRAFFIC CONTROL AND PROTECTION, STANDARD 701201	LSUM	1	1		
70100460	TRAFFIC CONTROL AND PROTECTION, STANDARD 701306	LSUM	1	1		
70106500	TEMPORARY BRIDGE TRAFFIC SIGNALS	EACH	1	1		
70107005	PAVEMENT MARKING BLACKOUT TAPE, 5"	FOOT	1006	1006		
70107025	CHANGEABLE MESSAGE SIGN	CAL DA	28	28		
70300100	SHORT TERM PAVEMENT MARKING	FOOT	270	270		
70300150	SHORT TERM PAVEMENT MARKING REMOVAL	SO FT	465	465		

\* SPECIALTY ITEM

REV. - MS

MODEL: Default  
 FILE: \\pww\illdot-pw-bentley.com\pww\illdot\Documents\DOT\_Offices\District\_7\Projects\74651\CAD\Drawings\CAD\Sheets\74651-rh-S00.dgn

USER NAME = Jessica.Hille	DESIGNED -	REVISED -
PLOT SCALE = 100.0000' / in.	DRAWN -	REVISED -
PLOT DATE = 3/29/2023	CHECKED -	REVISED -
	DATE -	REVISED -

STATE OF ILLINOIS  
DEPARTMENT OF TRANSPORTATION

SUMMARY OF  
QUANTITIES

SCALE: SHEET 2 OF 3 SHEETS STA. TO STA.

F.A.P. RTE. 821	SECTION (18BY)B	COUNTY WAYNE	TOTAL SHEETS 53	SHEET NO. 4
ILLINOIS FED. AID PROJECT			CONTRACT NO. 74651	

80% FED  
20% STATE

SUMMARY OF QUANTITIES			TOTAL QUANTITIES	CONSTRUCTION TYPE CODE		
CODE NO	ITEM	UNIT		0010		
70400100	TEMPORARY CONCRETE BARRIER	FOOT	438	438		
70400125	PINNING TEMPORARY CONCRETE BARRIER	EACH	59	59		
70400200	RELOCATE TEMPORARY CONCRETE BARRIER	FOOT	413	413		
70600250	IMPACT ATTENUATORS, TEMPORARY (NON-REDIRECTIVE), TEST LEVEL 3	EACH	2	2		
70600350	IMPACT ATTENUATORS, RELOCATE (NON-REDIRECTIVE), TEST LEVEL 3	EACH	2	2		
* 72501000	TERMINAL MARKER - DIRECT APPLIED	EACH	4	4		
* 78001110	PAINT PAVEMENT MARKING - LINE 4"	FOOT	1688	1688		
* 78100100	RAISED REFLECTIVE PAVEMENT MARKER	EACH	7	7		
* 78200005	GUARDRAIL REFLECTORS, TYPE A	EACH	16	16		
X0326440	SURFACE REMOVAL, VARIABLE DEPTH (SPECIAL)	SO YD	36	36		
X2501000	SEEDING, CLASS 2 (SPECIAL)	ACRE	0.4	0.4		
X4401198	HOT-MIX ASPHALT SURFACE REMOVAL, VARIABLE DEPTH	SO YD	2215	2215		
Z0004552	APPROACH SLAB REMOVAL	SO YD	107	107		

SUMMARY OF QUANTITIES			TOTAL QUANTITIES	CONSTRUCTION TYPE CODE		
CODE NO	ITEM	UNIT		0011		

\* SPECIALTY ITEM

REV. - MS

MODEL: Default  
 FILE: MainFile\_PlanUpload-cw\_bentley.com\_PWD001Documents\DOT\_Offices\District\_7\Projects\74651\CADDData\CAD\Sheets\74651-ph-SD00.dgn

USER NAME = jessica.hille	DESIGNED -	REVISED -
PLOT SCALE = 100.0000' / in.	DRAWN -	REVISIED -
PLOT DATE = 3/29/2023	CHECKED -	REVISIED -
	DATE -	REVISIED -

**STATE OF ILLINOIS  
DEPARTMENT OF TRANSPORTATION**

<b>SUMMARY OF QUANTITIES</b>	
SCALE:	SHEET 3 OF 3 SHEETS STA. TO STA.

F.A.P. RTE. 821	SECTION (18BY)B	COUNTY WAYNE	TOTAL SHEETS 53	SHEET NO. 5
ILLINOIS FED. AID PROJECT			CONTRACT NO. 74651	

**PROPOSED TYPICAL CROSS SECTION**  
 STATION 1094+50 TO STATION 1096+01  
 STATION 1101+00 TO STATION 1102+00

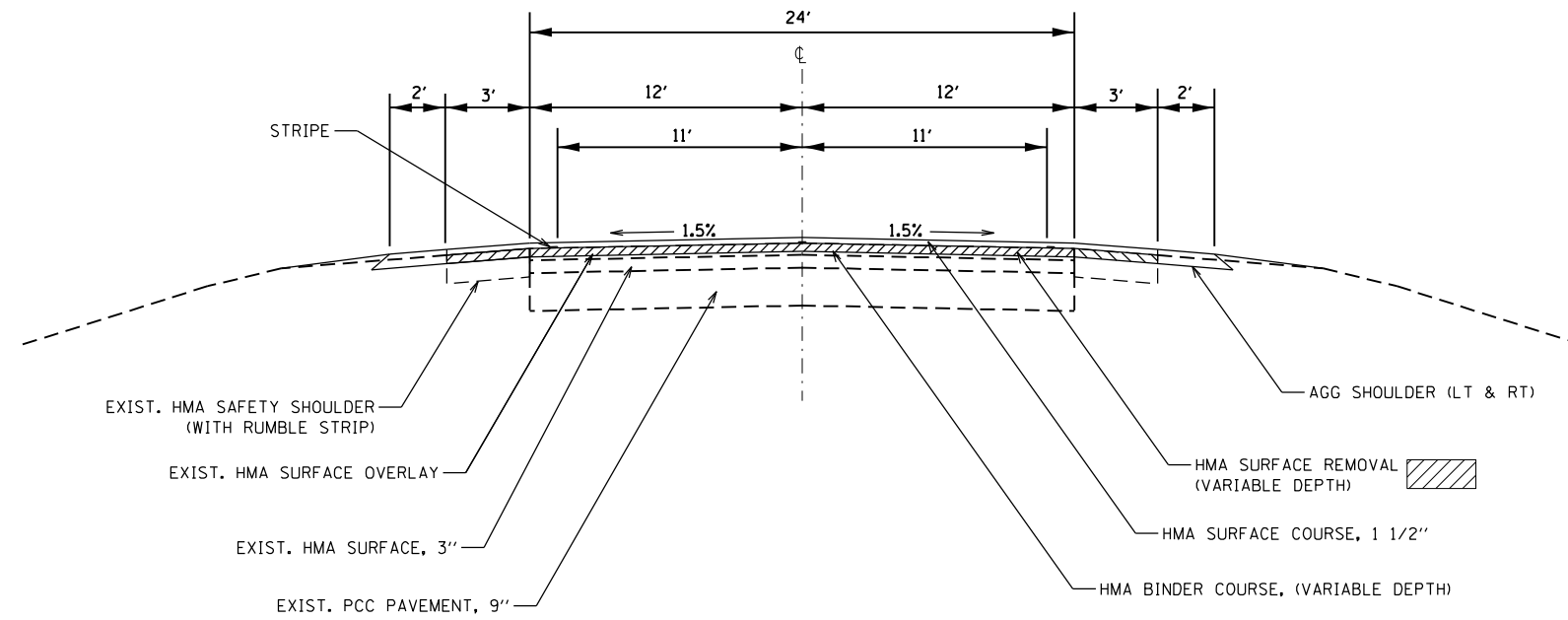

MODEL: Default  
 FILE: hmlr12.dwg  
 PROJECT: 74651\CAD\Drawings\CAD\Drawings\74651-188Y-188Y-188Y.dwg

USER NAME = Jessica.Hille	DESIGNED -	REVISED -
	DRAWN -	REVISED -
PLOT SCALE = 100,0000' / in.	CHECKED -	REVISED -
PLOT DATE = 3/29/2023	DATE -	REVISED -

**STATE OF ILLINOIS  
 DEPARTMENT OF TRANSPORTATION**

**PROPOSED TYPICAL  
 SECTIONS**

SCALE: SHEET 1 OF 2 SHEETS STA. TO STA.

F.A.P. RTE.	SECTION	COUNTY	TOTAL SHEETS	SHEET NO.
821	(188Y)B	WAYNE	53	6
CONTRACT NO. 74651			ILLINOIS FED. AID PROJECT	

PROPOSED TYPICAL CROSS SECTION

STATION 1096+01 TO STATION 1096+07  
STATION 1100+75 TO STATION 1101+00

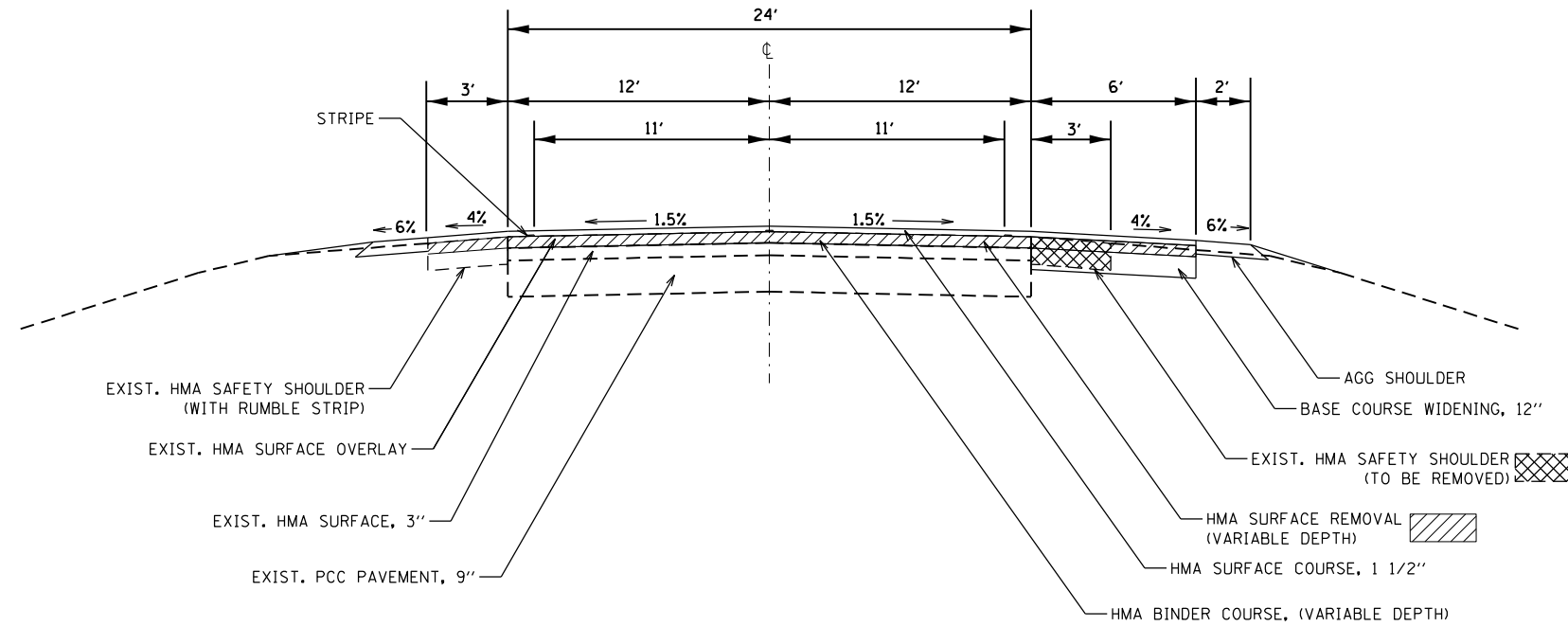

PROPOSED TYPICAL CROSS SECTION

STATION 1096+07 TO STATION 1098+22  
STATION 1098+62 TO STATION 1100+75

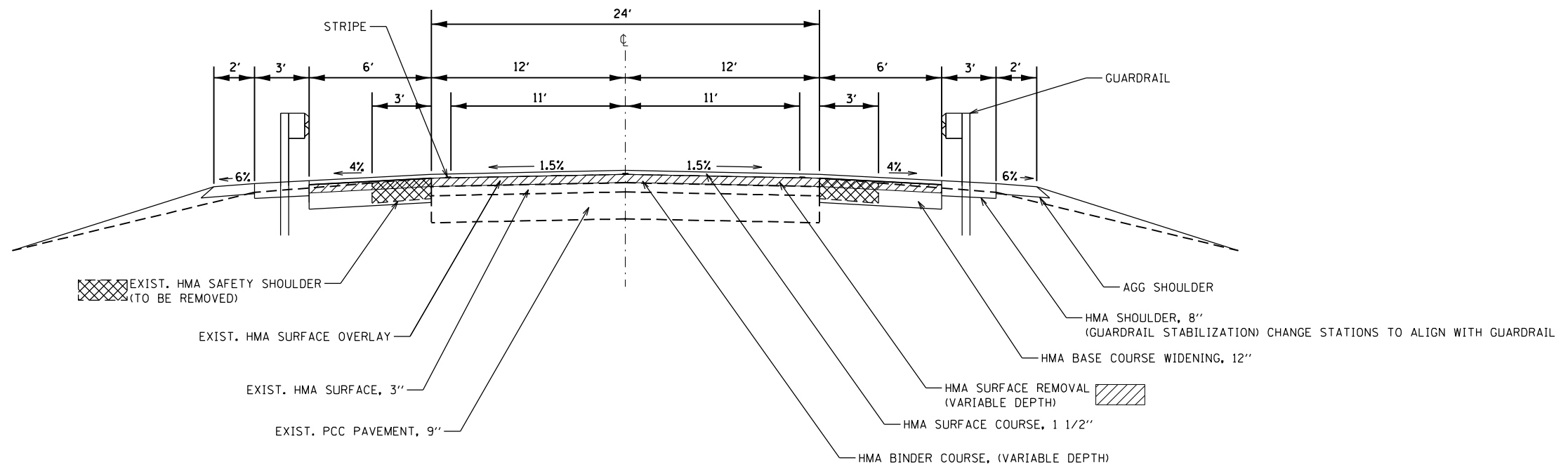

STATE OF ILLINOIS  
DEPARTMENT OF TRANSPORTATION

PROPOSED TYPICAL  
SECTIONS

USER NAME = Jessica.Hille	DESIGNED -	REVISED -
	DRAWN -	REVISED -
PLOT SCALE = 100,0000' / in.	CHECKED -	REVISED -
PLOT DATE = 3/29/2023	DATE -	REVISED -

SCALE: SHEET 2 OF 2 SHEETS STA. TO STA.

F.A.P. RTE. 821	SECTION (188Y)B	COUNTY WAYNE	TOTAL SHEETS 53	SHEET NO. 7
			CONTRACT NO. 74651	
ILLINOIS FED. AID PROJECT				

MODEL: Default  
FILE: h:\mfc\_projects\paw\_bentley.com\p\w\dot\Documents\DOT\_office\Director\_7\Project\74651\CADD\data\CAD\sheet\0774651\_sht-2\_typical.dgn

MODEL: Default  
 FILE: 304162\_304162-pw-bead-fwy.com\FWIDOT\Documents\DOT Office\Director\_T\Project\74651\CAD\Drawings\CAD\Sheet\074651-SP-Schedule\_Beg.dwg

PAVING SCHEDULE			35600724 HMA BASE COURSE WIDENING, 12"	40600290 BITUMINOUS MATERIALS (TACK COAT)	40600990 TEMPORARY RAMP	40603085 HOT-MIX ASPHALT BINDER COURSE, IL- 19.0, N70	40604052 HOT-MIX ASPHALT SURFACE COURSE, MIX "C", N70	40800050 INCIDENTAL HOT- MIX ASPHALT SURFACING	42000070 PAVEMENT CONNECTOR (HMA) FOR BRIDGE APPROACH SLAB	44000100 PAVEMENT REMOVAL	X0326440 SURFACE REMOVAL, VARIABLE DEPTH (SPECIAL)	X4401198 HOT-MIX ASPHALT SURFACE REMOVAL, VARIABLE DEPTH	Z0004552 APPROACH SLAB REMOVAL
STATION TO STATION			SQ YD	POUND	SQ YD	TON	TON	TON	SQ YD	SQ YD	SQ YD	SQ YD	SQ YD
RT	1096+00.7	1096+25.7	12.5	-	-	-	-	-	-	-	-	-	-
RT	1096+25.7	1100+74.5	299.2	-	-	-	-	-	-	-	-	-	-
RT	1100+74.5	1100+99.5	12.5	-	-	-	-	-	-	-	-	-	-
LT	1096+06.5	1096+31.5	12.5	-	-	-	-	-	-	-	-	-	-
LT	1096+31.5	1097+74.0	95.0	-	-	-	-	-	-	-	-	-	-
LT	1099+26.0	1100+50.0	82.7	-	-	-	-	-	-	-	-	-	-
LT	1100+50.0	1100+75.5	17.0	-	-	-	-	-	-	-	-	-	-
MAINLINE													
	1094+50.0	1096+00.7	-	339.1	-	-	-	-	-	-	-	-	-
	1096+00.7	1096+06.5	-	14.4	-	-	-	-	-	-	-	-	-
	1096+06.5	1097+74.0	-	452.3	-	-	-	-	-	-	-	-	-
	1096+50.0	1097+74.0	-	111.6	-	-	-	-	-	-	-	-	-
	1097+74.0	1097+84.0	-	27.0	-	-	-	-	-	-	-	-	-
	1099+16.0	1099+26.0	-	27.0	-	-	-	-	-	-	-	-	-
	1099+26.0	1100+00.0	-	66.6	-	-	-	-	-	-	-	-	-
	1099+26.0	1100+75.0	-	402.3	-	-	-	-	-	-	-	-	-
	1100+75.0	1100+99.5	-	60.6	-	-	-	-	-	-	-	-	-
	1100+74.5	1102+00.0	-	282.4	-	-	-	-	-	-	-	-	-
LT	1097+34.0	1097+74.0	-	-	80.0	-	-	-	-	-	-	-	-
LT	1099+26.0	1099+66.0	-	-	80.0	-	-	-	-	-	-	-	-
RT	1097+34.0	1097+74.0	-	-	80.0	-	-	-	-	-	-	-	-
RT	1099+26.0	1099+66.0	-	-	80.0	-	-	-	-	-	-	-	-
LT	1095+00.0		-	-	25.0	-	-	3.0	-	-	35.2	-	-
MAINLINE													
	1094+50.0	1095+00.0	-	-	-	14.0	14.0	-	-	-	-	-	-
	1095+00.0	1096+00.7	-	-	-	37.6	28.2	-	-	-	-	-	-
	1096+00.7	1096+06.5	-	-	-	2.4	1.8	-	-	-	-	-	-
	1096+06.5	1096+50.0	-	-	-	28.0	14.6	-	-	-	-	-	-
	1096+50.0	1097+00.0	-	-	-	58.8	16.8	-	-	-	-	-	-
	1097+00.0	1097+50.0	-	-	-	92.4	16.8	-	-	-	-	-	-
	1097+50.0	1097+74.0	-	-	-	53.8	8.1	-	-	-	-	-	-
	1099+26.0	1099+50.0	-	-	-	42.3	8.1	-	-	-	-	-	-
	1099+50.0	1100+00.0	-	-	-	64.4	16.8	-	-	-	-	-	-
	1100+00.0	1100+50.0	-	-	-	35.0	16.8	-	-	-	-	-	-
	1100+50.0	1100+75.0	-	-	-	11.2	8.4	-	-	-	-	-	-
	1100+75.0	1100+99.5	-	-	-	10.1	7.5	-	-	-	-	-	-
	1100+99.5	1101+50.0	-	-	-	18.9	14.1	-	-	-	-	-	-
	1101+50.0	1102+00.0	-	-	-	14.0	14.0	-	-	-	-	-	-
MAINLINE													
	1097+74.0	1097+84.0	-	-	-	-	-	-	40.0	-	-	-	-
	1099+16.0	1099+26.0	-	-	-	-	-	-	40.0	-	-	-	-
MAINLINE													
	1097+74.0	1098+02.1	-	-	-	-	-	-	-	74.9	-	-	-
	1098+81.8	1099+26.0	-	-	-	-	-	-	-	117.9	-	-	-
MAINLINE													
	1094+50.0	1097+74.0	-	-	-	-	-	-	-	-	-	1193.6	-
	1099+26.0	1102+00.0	-	-	-	-	-	-	-	-	-	1020.8	-
MAINLINE													
	1097+92.1	1098+22.1	-	-	-	-	-	-	-	-	-	-	53.3
	1098+61.8	1098+91.8	-	-	-	-	-	-	-	-	-	-	53.3
TOTALS:			532	1784	345	483	187	3	80	193	36	2215	107

STAGING SCHEDULE				70400100 TEMPORARY CONCRETE BARRIER	70400200 RELOCATE TEMPORARY CONCRETE BARRIER	70600250 IMPACT ATTENUATORS, TEMPORARY (NON- REDIRECTIVE), TEST LEVEL 3	70600350 IMPACT ATTENUATORS, RELOCATE (NON- REDIRECTIVE), TEST LEVEL 3	70400125 PINNING TEMPORARY CONCRETE BARRIER
STATION TO STATION				FOOT	FOOT	EACH	EACH	EACH
STAGE 1								
	TAPER: 4' LT TO 5' RT	1096+27.1	1097+39.3	112.5	-	-	-	-
	3.0/RT	1097+39.3	1099+51.8	212.5	-	-	-	-
	TAPER: 5' RT TO 4' LT	1099+51.8	1100+64.0	112.5	-	-	-	-
STAGE 2								
	TAPER: 4' RT TO 4' LT	1096+39.6	1097+39.3	-	100.0	-	-	-
	3.0/RT	1097+39.3	1099+51.8	-	212.5	-	-	-
	TAPER: 4' LT TO 4' RT	1099+51.8	1100+51.6	-	100.0	-	-	-
STAGE 1								
	4' LT	1096+27.1		-	-	1.0	-	-
	4' LT	1100+64.0		-	-	1.0	-	-
STAGE 2								
	4' RT	1096+39.6		-	-	-	1.0	-
	4' RT	1100+51.6		-	-	-	1.0	-
STAGE 1								
	2 SEGMENT TRANSITION	1097+39.3	1097+64.3	-	-	-	-	3.0
	TANGENT SECTION	1097+64.3	1099+26.8	-	-	-	-	39.0
	2 SEGMENT TRANSITION	1099+26.8	1099+51.8	-	-	-	-	3.0
STAGE 2								
	2 SEGMENT TRANSITION	1097+39.3	1097+64.3	-	-	-	-	3.0
	TANGENT SECTION	1097+64.3	1097+84.0	-	-	-	-	5.0
	BRIDGE	1097+84.0	1099+16.0	-	-	-	-	-
	TANGENT SECTION	1099+16.0	1099+26.8	-	-	-	-	3.0
	2 SEGMENT TRANSITION	1099+26.8	1099+51.8	-	-	-	-	3.0
TOTALS:				438	413	2	2	59

SHOULDER SCHEDULE			44004250 PAVED SHOULDER REMOVAL	48101500 AGGREGATE SHOULDER, TYPE B 6"	48203029 HMA SHOULDERS 8"
STATION TO STATION			SQ YD	SQ YD	SQ YD
LT	1096+06.5	1098+22.1	71.9	-	-
LT	1098+61.8	1100+75.0	71.1	-	-
RT	1096+00.7	1098+22.1	73.8	-	-
RT	1098+61.8	1100+99.5	79.2	-	-
LT	1094+50.0	1094+73.0	-	5.1	-
LT	1095+32.4	1098+02.9	-	60.1	-
LT	1098+96.9	1102+00.0	-	67.4	-
RT	1094+50.0	1098+03.0	-	78.4	-
RT	1098+96.9	1102+00.0	-	67.4	-
RT	1096+50.2	1096+60.2	-	-	2.2
RT	1096+60.2	1098+13.0	-	-	50.9
RT	1098+87.0	1099+88.6	-	-	33.9
RT	1099+88.6	1099+98.6	-	-	2.2
LT	1097+01.2	1097+11.2	-	-	2.2
LT	1097+11.2	1098+13.0	-	-	33.9
LT	1098+87.0	1100+39.8	-	-	50.9
LT	1100+39.8	1100+49.8	-	-	2.2
TOTALS:			296	279	179

SHOULDER RUMBLE STRIPS, 8 INCH			
LOCATION		SIDE	LENGTH FOOT
1094+50	1098+13	LT/RT	726.0
1098+87	1102+00	LT/RT	626.0
TOTAL =			1352.0

REV. - MS

USER NAME = Jessica.Hille	DESIGNED -	REVISED -
	DRAWN -	REVISED -
PLOT SCALE = 100,0000' / in.	CHECKED -	REVISED -
PLOT DATE = 3/29/2023	DATE -	REVISED -

STATE OF ILLINOIS  
 DEPARTMENT OF TRANSPORTATION

SCHEDULE OF  
 QUANTITIES

SCALE:	SHEET 1	OF 2	SHEETS	STA.	TO STA.
--------	---------	------	--------	------	---------

F.A.P. RTE.	SECTION	COUNTY	TOTAL SHEETS	SHEET NO.
821	(188Y)B	WAYNE	53	8
CONTRACT NO. 74651				
ILLINOIS FED. AID PROJECT				



MODEL: Default  
 FILE: \\blmfe-pw-bentley.com\P\INDOT\Documents\DOT Office\Director\_2\Projects\7465\ICAD\Drawn\CAD\sheet\0774651.rvt-ssched.dwg

STATION TO STATION		FOOT	EACH	EACH	EACH	EACH	FOOT
<b>GUARDRAIL SCHEDULE</b>							
		63000001 STEEL PLATE BEAM GUARDRAIL TYPE A, 6 FOOT POSTS	63100085 TRAFFIC BARRIER TERMINAL, TYPE 6	63100167 TRAFFIC BARRIER TERMINAL, TYPE 1 (SPECIAL) TANGENT	78200005 GUARDRAIL REFLECTORS, TYPE A	72501000 TERMINAL MARKER - DIRECT APPLIED	GUARDRAIL REMOVAL
<b>NORTHWEST QUADRANT</b>							
LT	1096+97.2	1097+47.2	-	-	1.0	1.0	-
LT	1097+47.2	1097+61.5	14.3	-	-	-	-
LT	1097+61.5	1097+99.0	-	1.0	-	-	-
<b>SOTHWEST QUADRANT</b>							
RT	1096+46.2	1096+96.2	-	-	1.0	1.0	-
RT	1096+96.2	1097+61.5	65.3	-	-	-	-
RT	1097+61.5	1097+99.0	-	1.0	-	-	-
<b>NORTHEAST QUADRANT</b>							
LT	1099+01.0	1099+38.5	-	1.0	-	-	-
LT	1099+38.5	1100+03.8	65.3	-	-	-	-
LT	1100+03.8	1100+53.8	-	-	1.0	1.0	-
<b>SOUTHWEST QUADRANT</b>							
RT	1099+01.0	1099+38.5	-	1.0	-	-	-
RT	1099+38.5	1099+52.6	14.1	-	-	-	-
RT	1099+52.6	1100+02.6	-	-	1.0	1.0	-
<b>REMOVAL</b>							
LT	1097+73.0	1099+38.0	-	-	-	-	165.0
RT	1097+47.0	1099+12.0	-	-	-	-	165.0
<b>TOTALS:</b>		<b>159</b>	<b>4</b>	<b>4</b>	<b>16</b>	<b>4</b>	<b>330</b>

EARTHWORK		20200100 EARTH EXCAVATION	EARTH EXCAVATION EMBANKMENT ADJUSTED FOR SHRINKAGE (25%)	EMBANKMENT	EARTHWORK BALANCE WASTE (+) OR SHORTAGE (-)	21101505 TOPSOIL EXCAVATION AND PLACEMENT	
	CU YD	CU YD	CU YD	CU YD	CU YD	CU YD	
LT	1094+50.00	1102+00.00	38	28.5	264	-235.5	133
RT	1094+50.00	1102+00.00	12	9	260	-251	102
CHANNEL EXCAVATION			488	366	0	366	0
<b>TOTALS:</b>		<b>50</b>	<b>403.5</b>	<b>524</b>	<b>-121</b>	<b>235</b>	

STATION TO STATION		28000250 TEMPORARY EROSION CONTROL SEEDING	X2501000 SEEDING, CLASS 2 (SPECIAL)	
	POUND	ACRE		
LT	1095+20.0	1098+50.0	10.4	0.10
RT	1096+00.0	1098+50.0	9.6	0.10
LT	1098+50.0	1102+00.0	13.2	0.13
RT	1098+50.0	1101+50.0	9.4	0.09
<b>TOTALS:</b>		<b>45</b>	<b>0.4</b>	

STATION TO STATION		70107005 PAVEMENT MARKING BLACKOUT TAPE, 5"	70300100 SHORT TERM PAVEMENT MARKING	70300150 SHORT TERM PAVEMENT MARKING REMOVAL	78001110 PAINT PAVEMENT MARKING LINE 4" - WHITE	78001110 PAINT PAVEMENT MARKING LINE 4" - YELLOW
	FOOT	FOOT	SQ FT	FOOT	FOOT	
STAGE 1	1094+50.0	1096+98.0	62.0	-	25.8	-
	1099+76.0	1102+00.0	56.0	-	23.3	-
	1096+15.0	1100+75.0	460.0	-	191.7	-
STAGE 2	1096+32.0	1100+60.0	428.0	-	178.3	-
<b>POST STAGE</b>						
EDGELINES	1094+50.0	1102+00.0	-	120.0	20.0	1500.0
CL SKIPS	1094+50.0	1102+00.0	-	150.0	25.0	188.0
<b>TOTALS:</b>		<b>1006</b>	<b>270</b>	<b>465</b>	<b>1688</b>	

REV. - MS

USER NAME = Jessica.Hille	DESIGNED -	REVISED -	<b>STATE OF ILLINOIS DEPARTMENT OF TRANSPORTATION</b>	<b>SCHEDULE OF QUANTITIES</b>		F.A.P. RTE.	SECTION	COUNTY	TOTAL SHEETS	SHEET NO.				
PLOT SCALE = 100,0000' / in.	DRAWN -	REVISED -		SCALE:	SHEET 2	OF 2	SHEETS	STA.	TO STA.	821	(188Y)B	WAYNE	53	9
PLOT DATE = 3/29/2023	CHECKED -	REVISED -		ILLINOIS		FED. AID PROJECT		CONTRACT NO. 74651						
	DATE -	REVISED -												

BM 462: STA. 1098+20, 23' LT. ELEV.=405.883  
CUT SQUARE IN THE NORTHWEST CORNER OF BRIDGE  
ON NORTHSIDE OF ILL 15.

BM 462A: STA. 1095+30, 50' LT. ELEV.=400.64  
CHISELED SQUARE ON THE EAST END OF A RCP IN THE  
NE QUADRANT OF IL 15 AND TR 815E.

PLAN	SURVEYED	DATE
	PLOTTED	BY
	ALIGNMENT CHECKED	
	GRADE CHECKED	
	STRUCTURE NOTATIONS CHECKED	
	NOTE BOOK NO.	
	CADD FILE NAME	

PROFILE	SURVEYED	DATE
	PLOTTED	BY
	GRADES CHECKED	
	STRUCTURE NOTATIONS CHECKED	
	NOTE BOOK NO.	
	CADD FILE NAME	

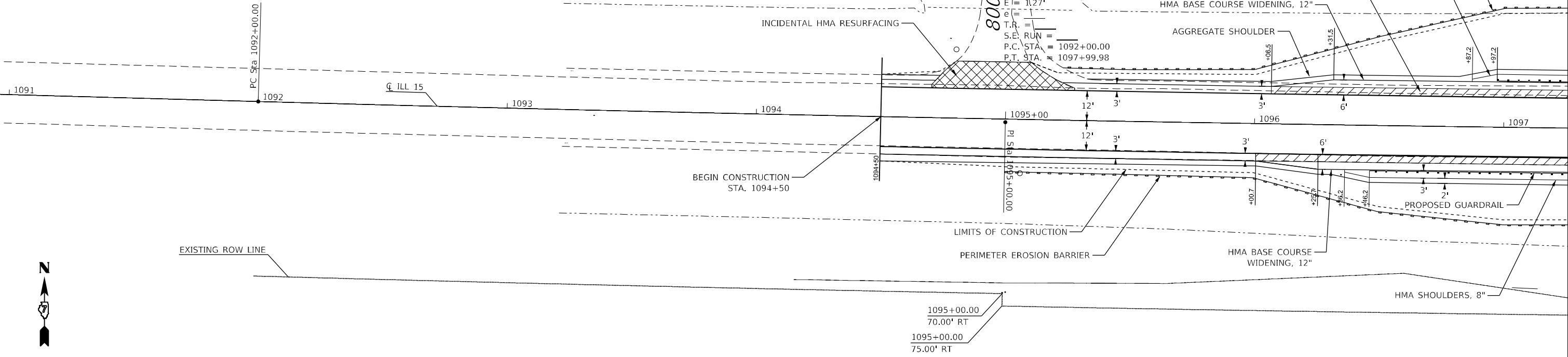
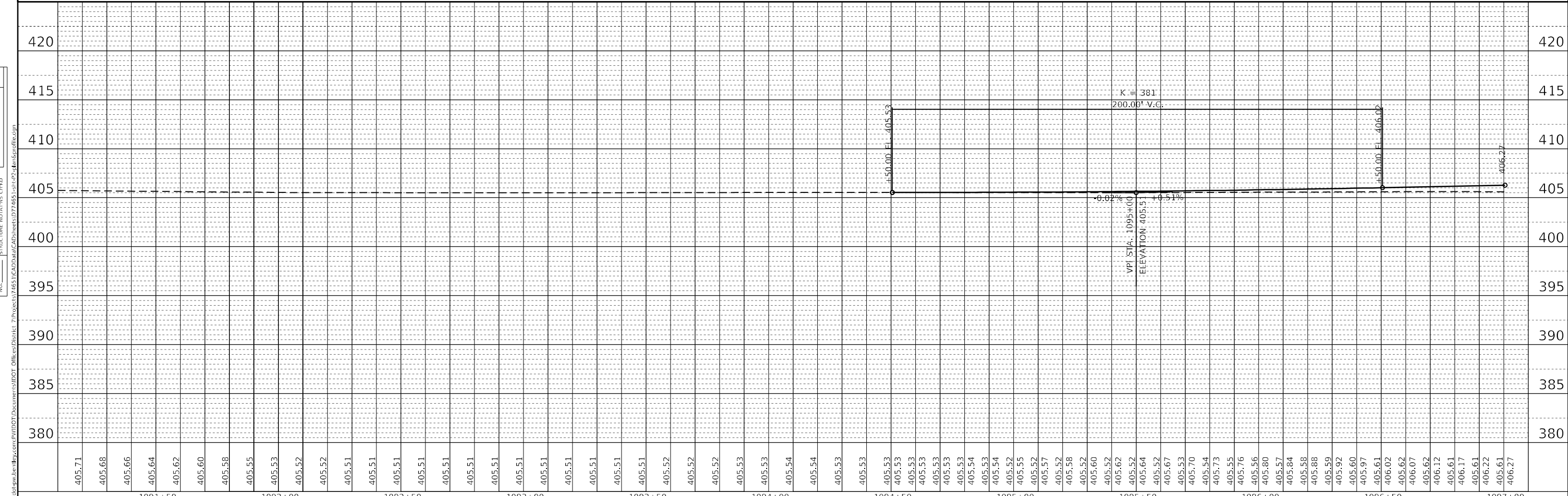

EXIST. CURVE C1  
PI STA. = 1095+00.00  
 $\Delta = 0^\circ 58' 15''$  (LT)  
 $D = 10^\circ 09' 42''$   
 $R = 35,411.97'$   
 $T = 300.00'$   
 $L = 999.99'$   
 $E = 11.27'$   
T.R. =  
S.E. RUN =  
P.C. STA. = 1092+00.00  
P.T. STA. = 1097+99.98



USER NAME = Jessica.Hille
PLOT SCALE = 40,0000 * / in.
PLOT DATE = 3/29/2023

DESIGNED -	REVISD -
DRAWN - R. Walker	REVISD -
CHECKED -	REVISD -
DATE -	REVISD -

**STATE OF ILLINOIS  
DEPARTMENT OF TRANSPORTATION**

**PLAN & PROFILE  
S.N. 096-0076**

SCALE: 5V:20H    SHEET 1 OF 2 SHEETS    STA. 1091+50 TO STA. 1097+00

F.A.P. RTE. 821	SECTION (18BY)B	COUNTY WAYNE	TOTAL SHEETS 53	SHEET NO. 10
CONTRACT NO. 74651				
ILLINOIS FED. AID PROJECT				



PLAN	SURVEYED	BY	DATE
	PLOTTED		
	ALIGNMENT CHECKED		
	GRADE CHECKED		
	STRUCTURE NOTATIONS CHECKED		
	NOTE BOOK NO.		
	CADD FILE NAME		

PROFILE	SURVEYED	BY	DATE
	PLOTTED		
	GRADES CHECKED		
	STRUCTURE NOTATIONS CHECKED		
	NOTE BOOK NO.		
	CADD FILE NAME		

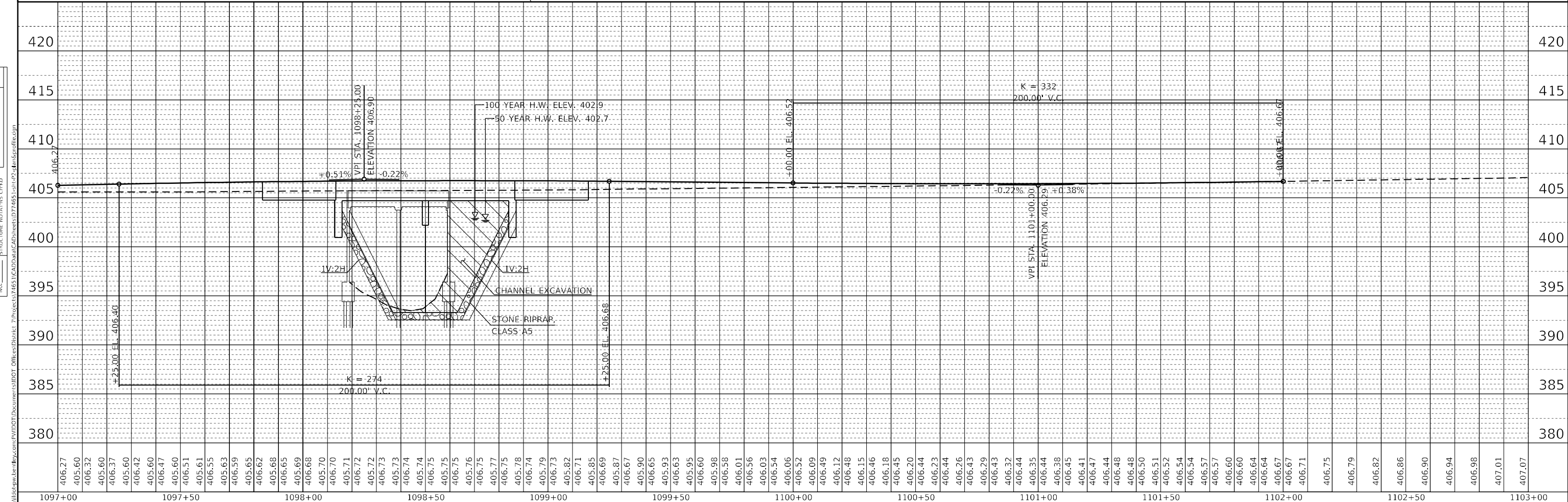
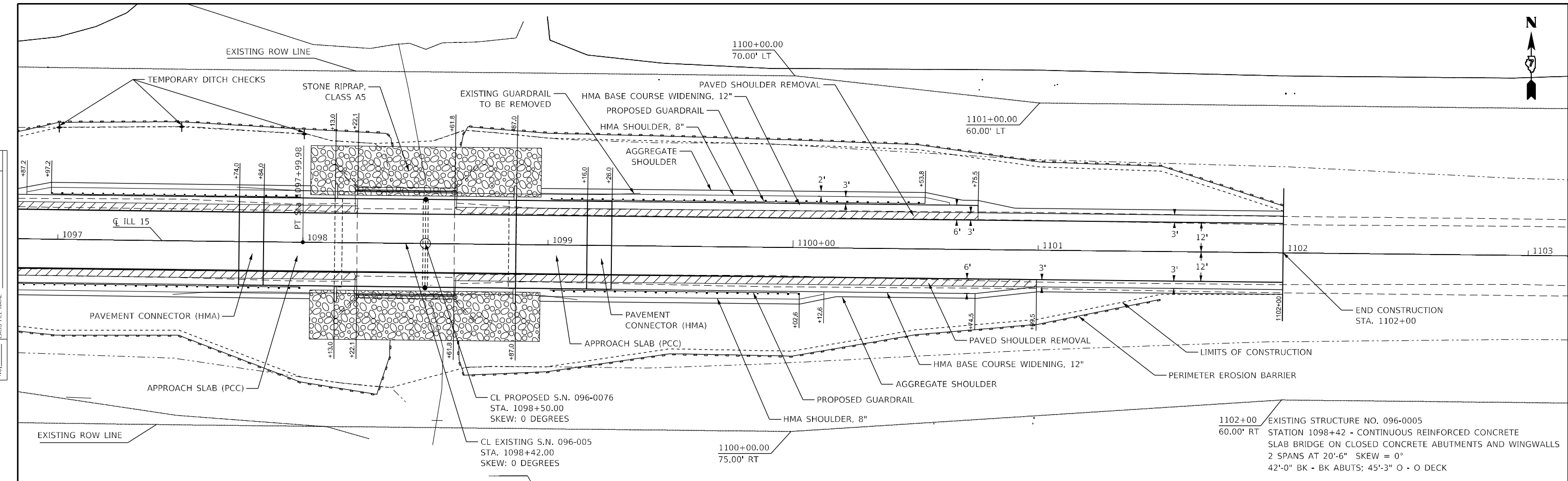

406.27	405.60	406.32	406.37	405.60	405.60	406.47	405.60	406.51	405.61	406.55	405.63	406.59	405.65	406.62	405.68	406.65	405.69	406.68	405.70	406.70	405.71	406.72	405.72	406.73	405.73	406.74	405.74	406.75	405.75	406.75	405.76	406.76	405.77	406.77	405.78	406.78	405.78	406.79	405.79	406.79	405.82	406.82	405.85	406.85	405.87	406.87	405.87	406.87	405.90	406.90	405.93	406.93	405.93	406.93	405.95	406.95	405.98	406.98	405.98	406.98	406.01	406.01	406.01	406.01	406.03	406.03	406.04	406.04	406.06	406.06	406.09	406.09	406.12	406.12	406.15	406.15	406.18	406.18	406.20	406.20	406.23	406.23	406.26	406.26	406.43	406.43	406.29	406.29	406.43	406.43	406.32	406.32	406.44	406.44	406.35	406.35	406.48	406.48	406.41	406.41	406.47	406.47	406.48	406.48	406.48	406.48	406.50	406.50	406.51	406.51	406.52	406.52	406.54	406.54	406.57	406.57	406.60	406.60	406.64	406.64	406.67	406.67	406.71	406.71	406.75	406.75	406.79	406.79	406.82	406.82	406.86	406.86	406.90	406.90	406.94	406.94	406.98	406.98	407.01	407.01	407.07	407.07	420	420	415	415	410	410	405	405	400	400	395	395	390	390	385	385	380	380	1097+00	1097+50	1098+00	1098+50	1099+00	1099+50	1100+00	1100+50	1101+00	1101+50	1102+00	1102+50	1103+00
--------	--------	--------	--------	--------	--------	--------	--------	--------	--------	--------	--------	--------	--------	--------	--------	--------	--------	--------	--------	--------	--------	--------	--------	--------	--------	--------	--------	--------	--------	--------	--------	--------	--------	--------	--------	--------	--------	--------	--------	--------	--------	--------	--------	--------	--------	--------	--------	--------	--------	--------	--------	--------	--------	--------	--------	--------	--------	--------	--------	--------	--------	--------	--------	--------	--------	--------	--------	--------	--------	--------	--------	--------	--------	--------	--------	--------	--------	--------	--------	--------	--------	--------	--------	--------	--------	--------	--------	--------	--------	--------	--------	--------	--------	--------	--------	--------	--------	--------	--------	--------	--------	--------	--------	--------	--------	--------	--------	--------	--------	--------	--------	--------	--------	--------	--------	--------	--------	--------	--------	--------	--------	--------	--------	--------	--------	--------	--------	--------	--------	--------	--------	--------	--------	--------	--------	--------	--------	--------	--------	--------	--------	--------	-----	-----	-----	-----	-----	-----	-----	-----	-----	-----	-----	-----	-----	-----	-----	-----	-----	-----	---------	---------	---------	---------	---------	---------	---------	---------	---------	---------	---------	---------	---------

USER NAME = Jessica.Hille	DESIGNED -	REVISED -
	DRAWN - R. Walker	REVISED -
PLOT SCALE = 40,0000 * / in.	CHECKED -	REVISED -
PLOT DATE = 3/29/2023	DATE -	REVISED -

<b>STATE OF ILLINOIS DEPARTMENT OF TRANSPORTATION</b>			
<b>PLAN &amp; PROFILE S.N. 096-0076</b>			
SCALE: 5V:20H	SHEET 2	OF 2 SHEETS	STA. 1097+00 TO STA. 1103+00

F.A.P. RTE. 821	SECTION (18BY)B	COUNTY WAYNE	TOTAL SHEETS 53	SHEET NO. 11
CONTRACT NO. 74651				
ILLINOIS FED. AID PROJECT				



EXIST. CURVE C1  
 PI STA. = 1095+00.00  
 $\Delta = 0^\circ 58' 15''$  (LT)  
 $D = 0^\circ 09' 42''$   
 $R = 35,411.97'$   
 $T = 300.00'$   
 $L = 599.99'$   
 $E = 11.27'$   
 $c =$   
 $T.R. =$   
 $S.E. RUN =$   
 $P.C. STA. = 1092+00.00$   
 $P.T. STA. = 1097+99.98$

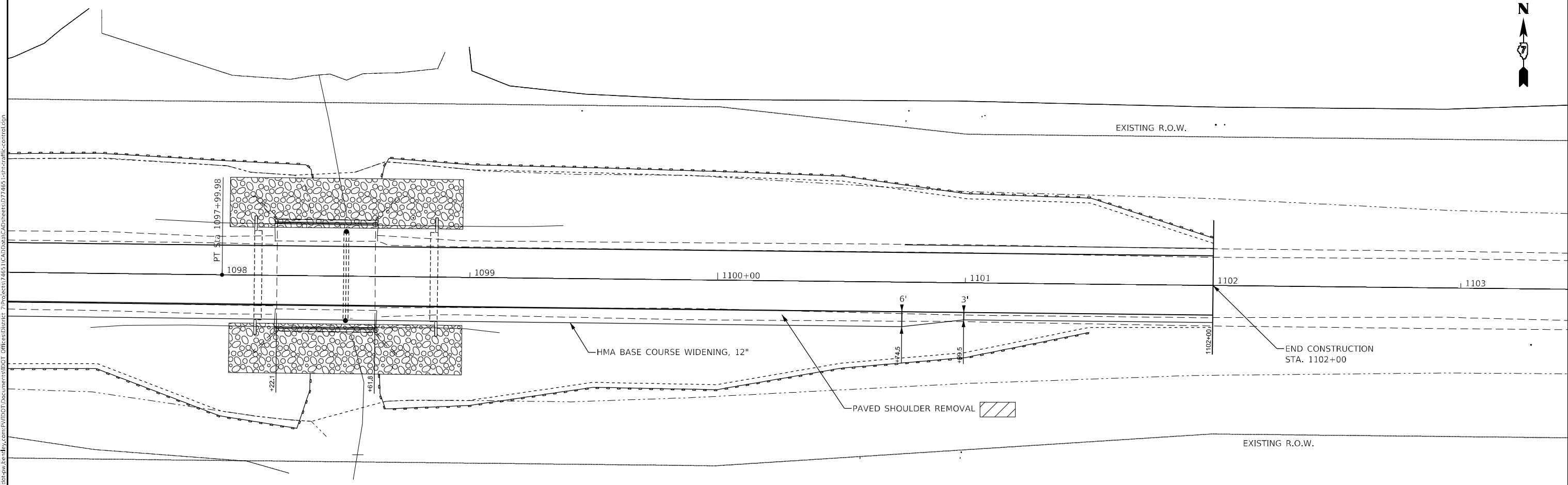
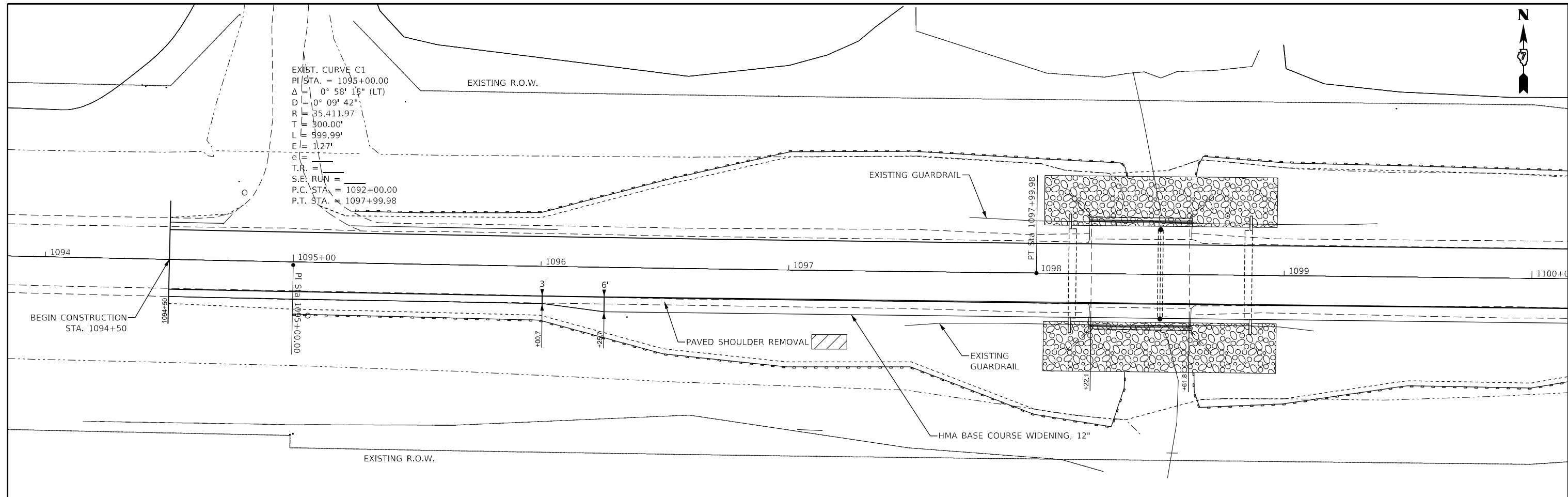

MODEL: Default  
 FILE: h:\mfc\_p\p\subject-cw\bea\mfc.com\PIV\DOT\Documents\DOT\_Offices\Director\_TrafficControl\Project\74651\CAD\Drawings\Drawings\TrafficControl.dgn

USER NAME = jessica.Hille	DESIGNED -	REVISED -
DRAWN -	REVISED -	
PLOT SCALE = 40,0000 * / in.	CHECKED -	REVISED -
PLOT DATE = 3/29/2023	DATE -	REVISED -

**STATE OF ILLINOIS  
DEPARTMENT OF TRANSPORTATION**

**TRAFFIC CONTROL PLAN  
PRE-STAGE**

SCALE: SHEET 1 OF 1 SHEETS STA. TO STA.

F.A.P. RTE.	SECTION	COUNTY	TOTAL SHEETS	SHEET NO.
821	(188Y)B	WAYNE	53	12
CONTRACT NO. 74651				
ILLINOIS FED. AID PROJECT				



EXIST. CURVE C1  
 PI STA. = 1095+00.00  
 $\Delta = 0^\circ 58' 15''$  (LT)  
 $D = 0^\circ 09' 42''$   
 $R = 35,411.97'$   
 $L = 300.00'$   
 $E = 599.99'$   
 $e = 1.27'$   
 T.R. =  
 S.E. RUN =  
 P.C. STA. = 1092+00.00  
 P.T. STA. = 1097+99.98

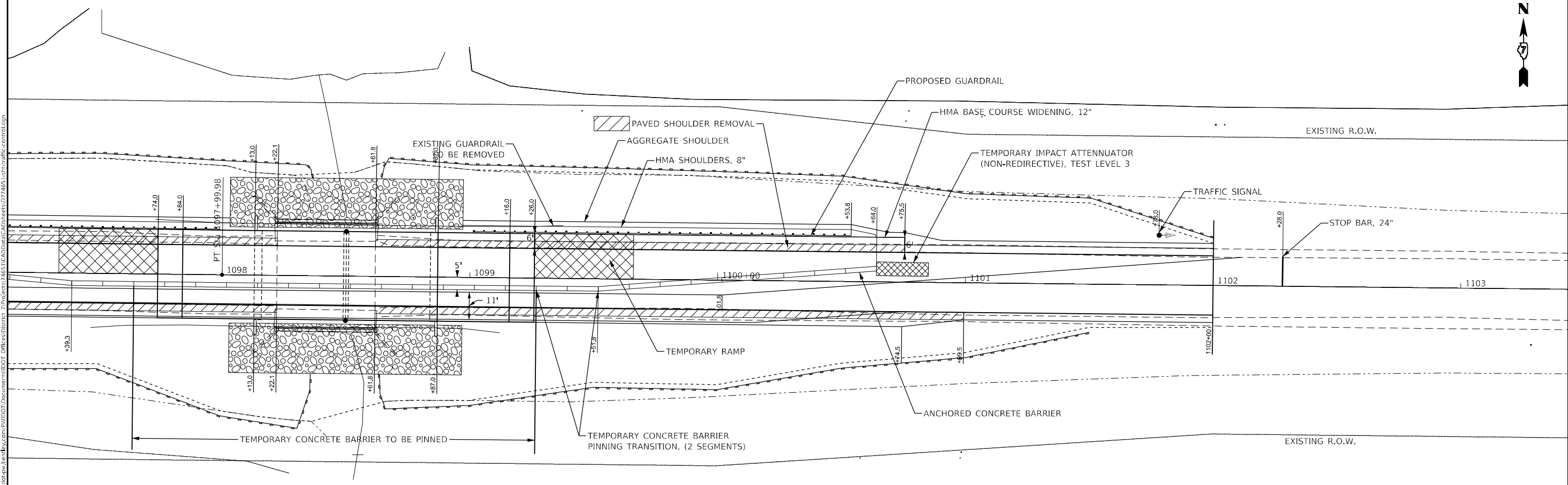
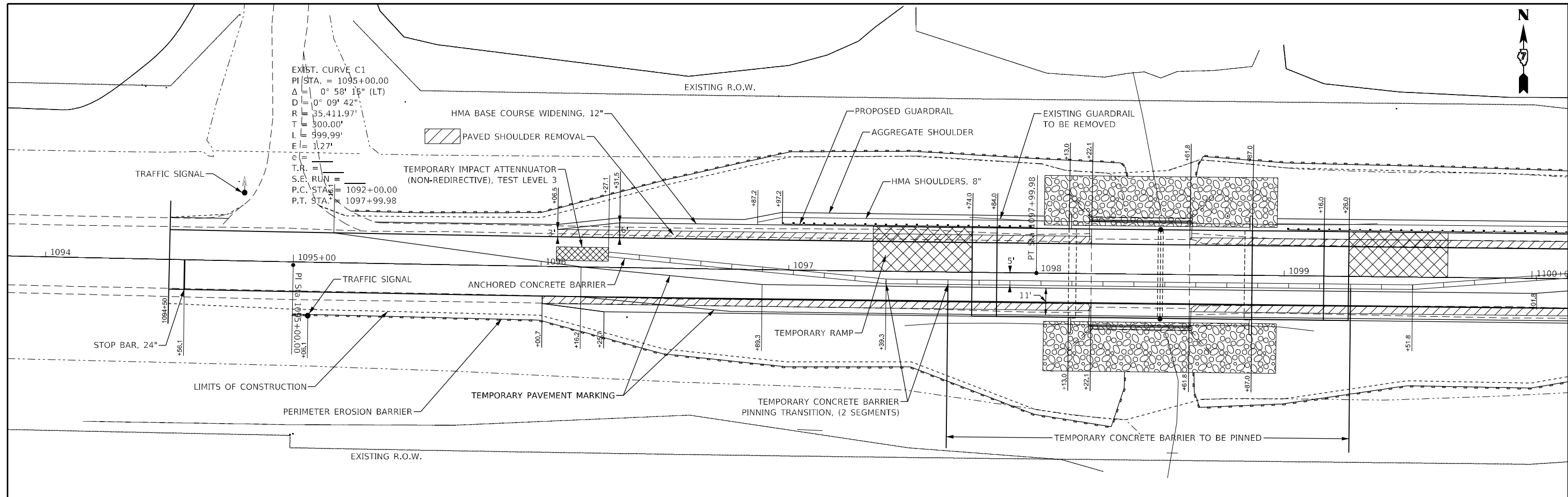

MODEL: Default  
 FILE: h:\mifc\p\h\h\dot\documents\DOT Office\Director\_2\Projects\74651\UCAD\Drawings\Drawings\74651-PT-Traffic-control.dwg  
 PLOT DATE = 3/29/2023

USER NAME = Jessica.Hille	DESIGNED -	REVISED -
PLOT SCALE = 40,0000 * / in.	DRAWN -	REVISED -
PLOT DATE = 3/29/2023	CHECKED -	REVISED -
	DATE -	REVISED -

**STATE OF ILLINOIS  
 DEPARTMENT OF TRANSPORTATION**

**TRAFFIC CONTROL PLAN  
 STAGE 1**

SCALE: SHEET 1 OF 1 SHEETS STA. TO STA.

F.A.P. RTE. 821	SECTION (188Y)B	COUNTY WAYNE	TOTAL SHEETS 53	SHEET NO. 13
CONTRACT NO. 74651				
ILLINOIS FED. AID PROJECT				



EXIST. CURVE C1  
 PI STA. = 1095+00.00  
 $\Delta = 0^\circ 58' 15''$  (LT)  
 $D = 0^\circ 09' 42''$   
 $R = 35,411.97'$   
 $L = 300.00'$   
 $E = 599.99'$   
 $C = 1.27'$   
 T.R. =  
 S.E. RUN =  
 P.C. STA. = 1092+00.00  
 P.T. STA. = 1097+99.98

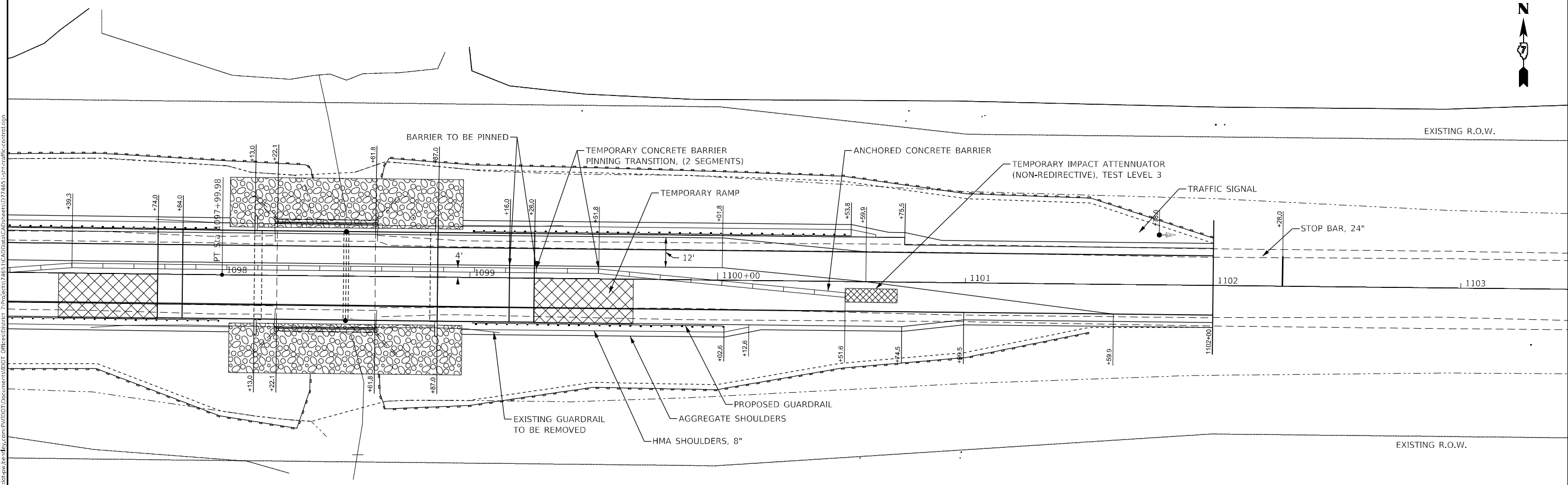
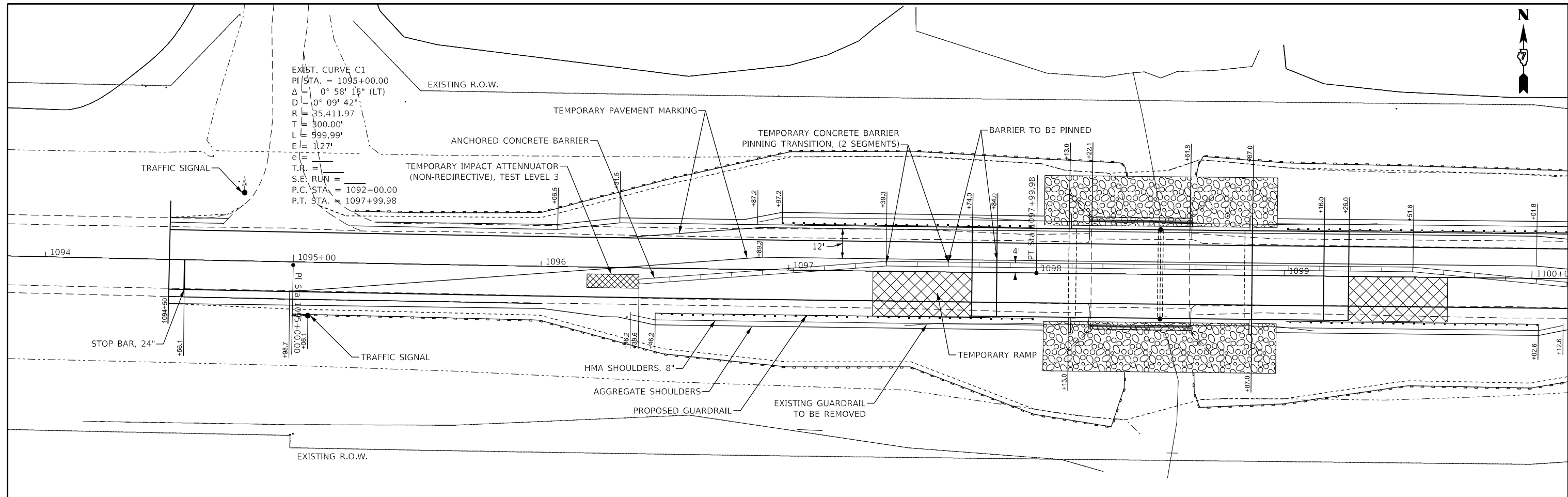

MODEL: Default  
 FILE NAME: p:\project\new\bea\p\p\DOT\Documents\DOT Office\Director\_2\Project\74651\CAD\Drawings\74651-PT-Traffic-control.dwg  
 PLOT DATE = 3/29/2023

USER NAME = Jessica.Hille	DESIGNED -	REVISED -
PLOT SCALE = 40,0000 * / in.	DRAWN -	REVISED -
PLOT DATE = 3/29/2023	CHECKED -	REVISED -
	DATE -	REVISED -

**STATE OF ILLINOIS  
DEPARTMENT OF TRANSPORTATION**

**TRAFFIC CONTROL PLAN  
STAGE 2**

SCALE: SHEET 1 OF 1 SHEETS STA. TO STA.

F.A.P. RTE. 821	SECTION (188Y)B	COUNTY WAYNE	TOTAL SHEETS 53	SHEET NO. 14
CONTRACT NO. 74651				
ILLINOIS FED. AID PROJECT				



EXIST. CURVE C1  
 P.I. STA. = 1095+00.00  
 $\Delta = 0^\circ 58' 15''$  (LT)  
 $D = 0^\circ 09' 42''$   
 $R = 35,411.97'$   
 $T = 300.00'$   
 $L = 599.99'$   
 $E = 1.27'$   
 $C =$   
 $T.R. =$   
 $S.E. RUN =$   
 P.C. STA. = 1092+00.00  
 P.T. STA. = 1097+99.98

 SURFACE REMOVAL, VARIABLE DEPTH (SPECIAL) AND INCIDENTAL HMA

 HMA SURFACE REMOVAL, VARIABLE DEPTH AND MAINLINE HMA COURSES

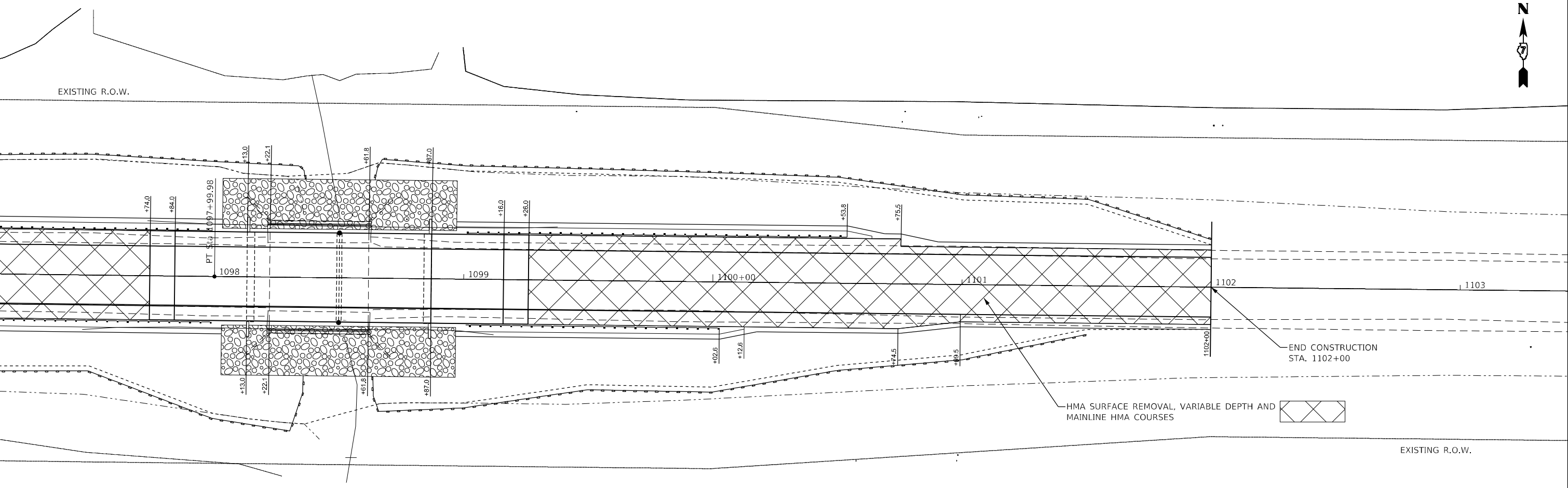
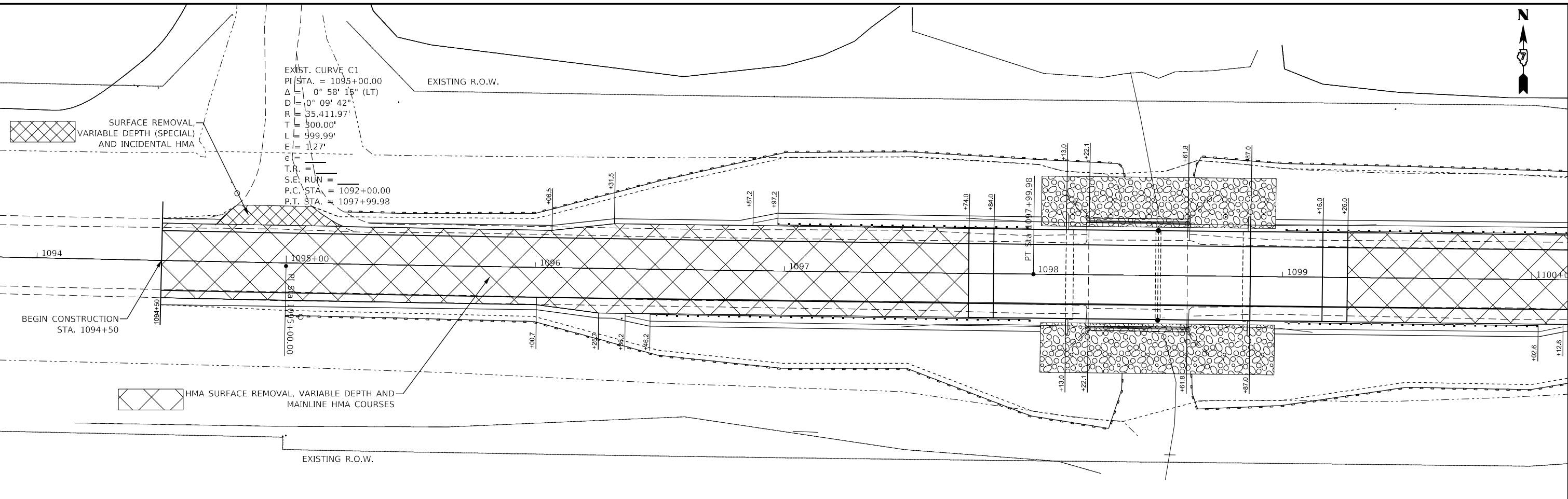

MODEL: Default  
 FILE NAME: p:\projects\new\bea\p\p\DOT\Documents\DOT Office\Director\_2\Projects\74651\CAD\data\CAD\sheet0774651-ct-traffic-control.dgn

USER NAME = Jessica.Hille	DESIGNED -	REVISED -
PLOT SCALE = 40,0000 * / in.	DRAWN -	REVISED -
PLOT DATE = 3/29/2023	CHECKED -	REVISED -
	DATE -	REVISED -

**STATE OF ILLINOIS  
 DEPARTMENT OF TRANSPORTATION**

**TRAFFIC CONTROL PLAN  
 POST-STAGE**

SCALE: SHEET 1 OF 1 SHEETS STA. TO STA.

F.A.P. RTE. 821	SECTION (188Y)B	COUNTY WAYNE	TOTAL SHEETS 53	SHEET NO. 15
CONTRACT NO. 74651				
ILLINOIS FED. AID PROJECT				

Bench Mark: BM 462 Chiseled "□" on northwest corner of existing structure 096-0005; 23' L. Sta. 1098+20; Elev. 405.883

Existing Structure- S.N. 096-0005 Built in 1920 as F.A.P. Rte. 821, Section 18B at Sta 1098+42. The single span structure was reconstructed in 1956 with a new reinforced concrete slab superstructure bridge supported on the existing closed abutments and untreated timber piles. The existing abutments were widened in-kind and a new center pier with precast piles was built as part of the reconstruction. The two-span slab bridge has an out-to-out width of 45'-4" and a back-to-back abutment length of 42'-0" with no skew. Existing structure to be removed and replaced. Traffic to be maintained using stage construction.

No salvage

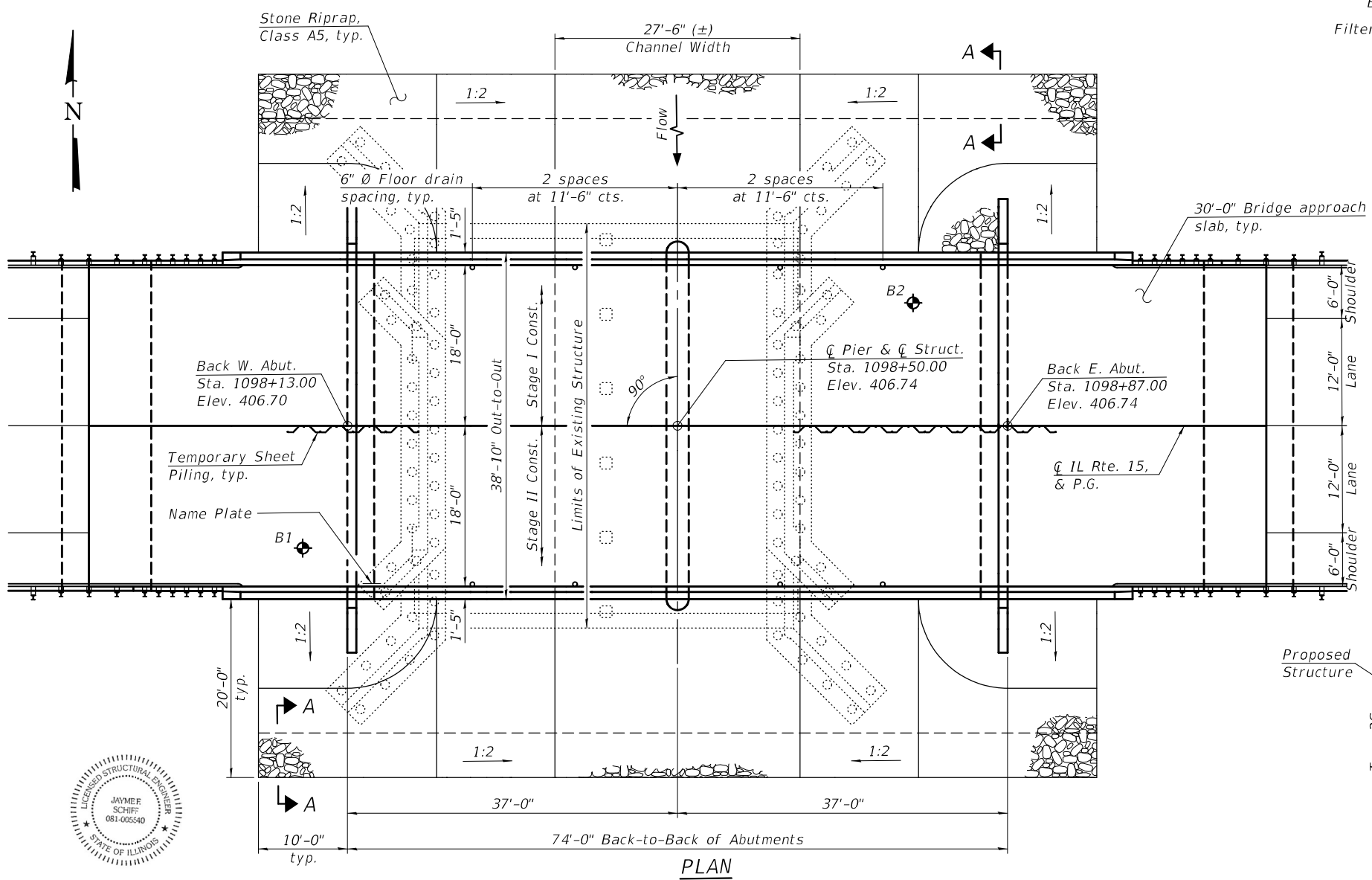
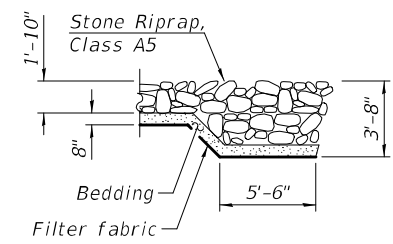
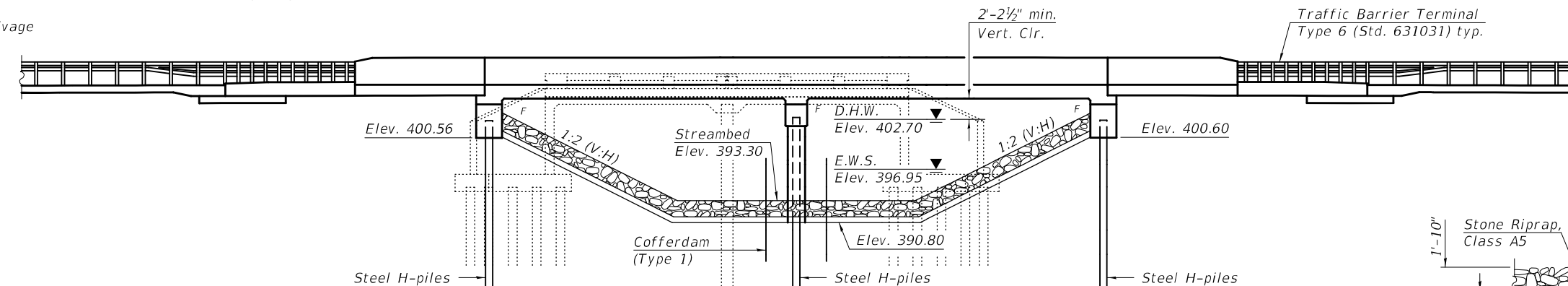

**INDEX OF SHEETS**

- 1 General Plan & Elevation
- 2 General Data
- 3 Stage Construction Details
- 4 Temporary Sheet Piling
- 5 Temporary Concrete Barrier for Stage Construction
- 6-7 Top of Slab Elevations
- 8-9 Top of Approach Slab Elevations
- 10-12 Superstructure
- 13 Superstructure Details
- 14-15 Bridge Approach Slab Details
- 16-18 Abutments
- 19-20 Pier
- 21 HP Pile Details
- 22 Bar Splicer Assembly & Mechanical Splicer Details
- 23 Concrete Parapet Slipforming Option
- 24-25 Soil Boring Logs

**DESIGN SPECIFICATIONS**

2020 AASHTO LRFD Bridge Design Specifications, 9th Edition

**DESIGN STRESSES**

**FIELD UNITS**

f'c = 3,500 psi  
 f'c = 4,000 psi (Superstructure)  
 fy = 60,000 psi (Reinforcement)

**LOADING HL-93**

Allow 50#/sq.ft. for Future Wearing Surface.

**SEISMIC DATA**

Seismic Performance Zone (SPZ) = 2  
 Design Spectral Acceleration at 1.0 sec. (SD1) = 0.288g  
 Design Spectral Acceleration at 0.2 sec. (SD5) = 0.690g  
 Soil Site Class = D

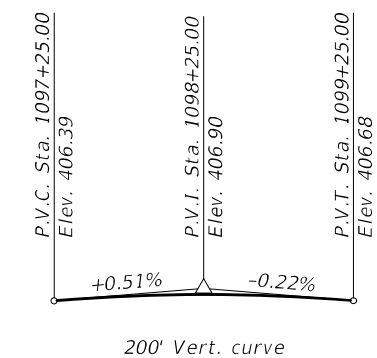

**PROFILE GRADE**

(along Q of IL Rte. 15)

**GENERAL PLAN AND ELEVATION**

**ILLINOIS ROUTE 15 OVER  
 MILLER CREEK  
 F.A.P. RTE. 821 - SEC. (18BY)B  
 WAYNE COUNTY  
 STATION 1098+50.00  
 STRUCTURE NO. 096-0076**

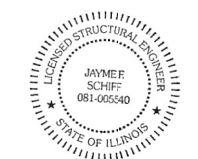
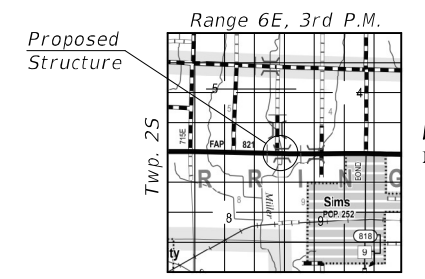

EXPIRES 11-30-2024

DESIGNED - HAMEED S. SALIH	EXAMINED - <i>Jaymee Schiff</i>	DATE - 4-26-2023
CHECKED - PAUL S. JOHNSON	ENGINEER OF BRIDGE DESIGN	
DRAWN - ANTHONY J. NOVELLO	PASSED - <i>Jaymee Schiff</i>	REVISED -
CHECKED - HSS / PSJ	ENGINEER OF BRIDGES AND STRUCTURES	REVISED -

STATE OF ILLINOIS  
 DEPARTMENT OF TRANSPORTATION

SHEET 1 OF 25 SHEETS

F.A.P. RTE.	SECTION	COUNTY	TOTAL SHEETS	SHEET NO.
821	(18BY)B	WAYNE	53	16
CONTRACT NO. 74651				
ILLINOIS FED. AID PROJECT				

MODEL: 0960076-74651-001  
 FILE NAME: p:\w\idp\w\benley.com\p\w\idp\Documents\IDOT Offices\Bureau of Bridges and Structures\Projects\0960076\CADD Plans\0960076-74651

4/25/2023 3:22:54 PM



**GENERAL NOTES**

Reinforcement bars designated (E) shall be epoxy coated.  
 The Contractor shall make allowance for the deflection of forms, shrinkage, and settlement of falsework. Forms for deck slab shall be removed prior to placement of bridge approach slab.  
 Layout of the slope protection system may be varied to suit ground conditions in the field as directed by the Engineer.  
 Excavation behind existing abutment walls shall be performed to balance front and back soil pressure before removing the existing superstructure. The Contractor shall sawcut the upper portion of the existing abutment at the stage removal line before Stage I removal to ensure the remaining portion will not be prematurely damaged.  
 Granular Backfill behind the abutments shall be compacted according to Article 205.06 of the Standard Specifications.

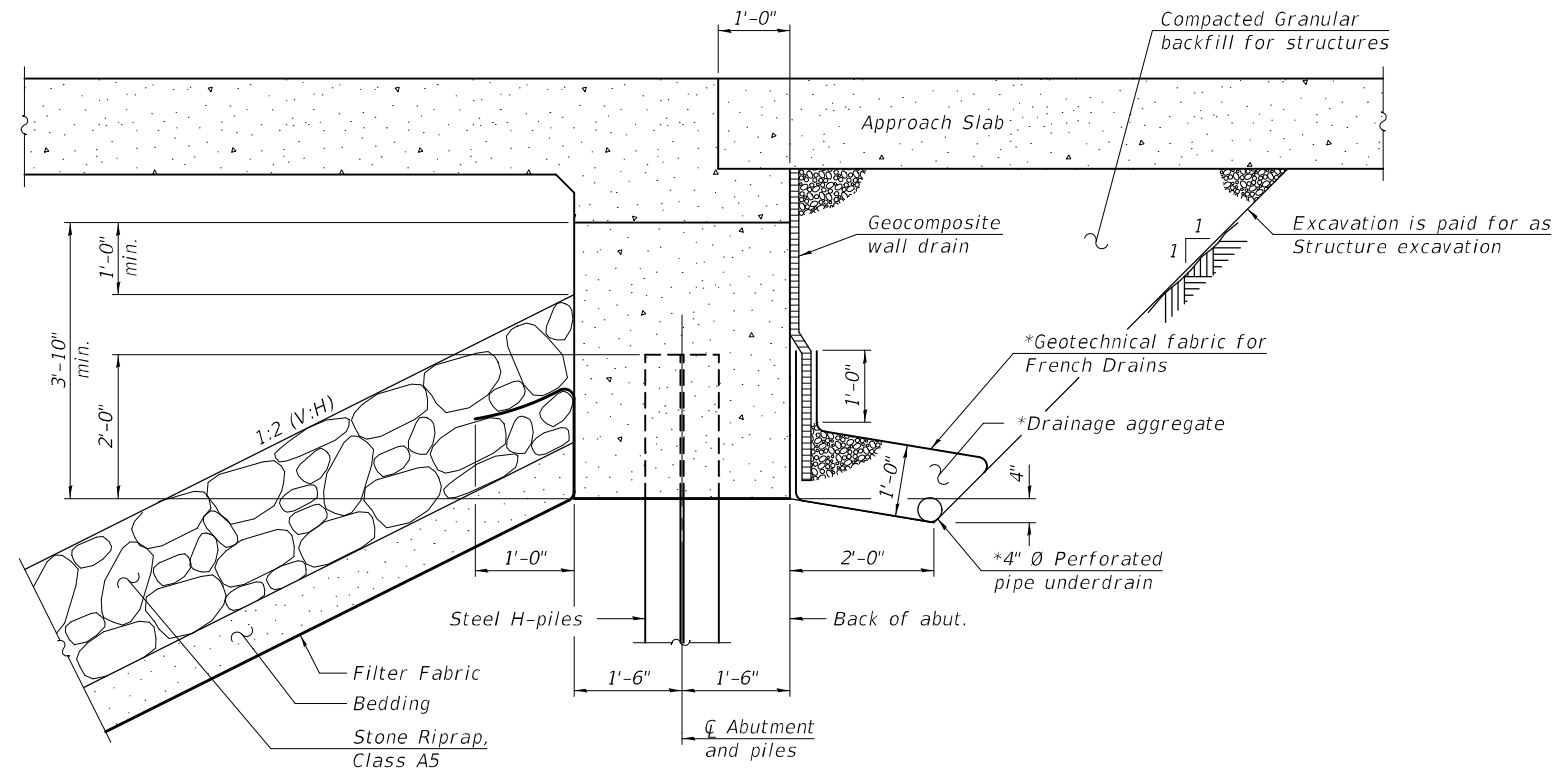

**SECTION THRU INTEGRAL ABUTMENT**

\*Included in the cost of Pipe Underdrains for Structures.

Note:  
 All drainage system components shall extend to 2'-0" from the end of each wingwall except an outlet pipe shall extend until intersecting with the side slopes. The pipes shall drain into concrete headwalls. (See Article 601.05 of the Standard Specifications and Highway Standard 601101).

STATION 1098+50.00  
 BUILT 20 BY  
 STATE OF ILLINOIS  
 F.A.P. RTE. 821 SEC. (18BY)B  
 LOADING HL-93  
 STRUCTURE NO. 096-0076

**NAME PLATE**  
 See Std. 515001

**WATERWAY INFORMATION**

Drainage Area = 4.1 sq. miles      Low Grade Elev. = 405.5 at Sta. 1095+50

Flood	Freq. Yr.	Q C.F.S.	Opening Sq. Ft.		Nat. H.W.E.	Head - Ft.		Headwater El.	
			Exist.	Prop.		Exist.	Prop.	Exist.	Prop.
Min. Calc.	10	1120	290	340	402.1	0.5	0.5	402.6	402.6
Design	50	1800	310	380	402.7	1.2	0.9	403.9	403.6
Base	100	2100	320	390	402.9	1.9	1.1	404.8	404.0
Scour Check	200	2420	330	400	403.1	2.0	1.3	405.1	404.4
Max. Calc.	500	2880	340	420	403.4	2.2	1.7	405.6	405.1

10 Year Velocity through Existing Bridge = 3.9 fps  
 10 Year Velocity through Proposed Bridge = 3.3 fps

**DESIGN SCOUR ELEVATION TABLE**

Event / Limit	Design Scour Elevations (ft.)			
	W. Abut.	Pier	E. Abut.	Item 113
Q100	400.56	388.10	400.60	8
Q200	400.56	387.30	400.60	
Design	400.56	388.10	400.60	
Check	400.56	387.30	400.60	

**TOTAL BILL OF MATERIAL**

ITEM	UNIT	SUPER	SUB	TOTAL
Removal of Existing Structures	Each			1
Stone Riprap, Class A5	Sq. Yd.		748	748
Filter Fabric	Sq. Yd.		748	748
Structure Excavation	Cu. Yd.		134	134
Protective Coat	Sq. Yd.	626		626
Concrete Structures	Cu. Yd.		104.9	104.9
Concrete Superstructure	Cu. Yd.	188.3		188.3
Bridge Deck Grooving	Sq. Yd.	499		499
Concrete Superstructure (Approach Slab)	Cu. Yd.	105.9		105.9
Reinforcement Bars, Epoxy Coated	Pound	90,830	13,330	104,160
Bar Splicers	Each	404	138	542
Temporary Sheet Piling	Sq. Ft.		1,062	1,062
Name Plates	Each	1		1
Cofferdam (Type 1) (Location-1)	Each		1	1
Furnishing Steel Piles HP14X89	Foot		1,044	1,044
Driving Piles	Foot		1,044	1,044
Granular Backfill for Structures	Cu. Yd.		68	68
Geocomposite Wall Drain	Sq. Yd.		47	47
Pipe Underdrains for Structures 4"	Foot		128	128
Floor Drains	Each	8		8
Cofferdam Excavation	Cu. Yd.		96	96

MODEL: 0960076-74651-017  
 FILE NAME: p:\w\id\p\w\benley.com\FWIDOT\Documents\DOT Offices\Bureau of Bridges and Structures\Projects\0960076\CADD Plans\0960076-74651

DESIGNED - HAMEED S. SALIH  
 CHECKED - PAUL S. JOHNSON  
 DRAWN - ANTHONY J. NOVELLO  
 CHECKED - HSS / PSJ

EXAMINED  
 PASSED  
 ENGINEER OF BRIDGE DESIGN  
 ENGINEER OF BRIDGES AND STRUCTURES

DATE - APRIL 26, 2023  
 REVISED -  
 REVISED -

STATE OF ILLINOIS  
 DEPARTMENT OF TRANSPORTATION

GENERAL DATA  
 STRUCTURE NO. 096-0076

SHEET 2 OF 25 SHEETS

F.A.P. RTE. 821  
 SECTION (18BY)B  
 COUNTY WAYNE  
 TOTAL SHEETS 53  
 SHEET NO. 17  
 CONTRACT NO. 74651  
 ILLINOIS FED. AID PROJECT

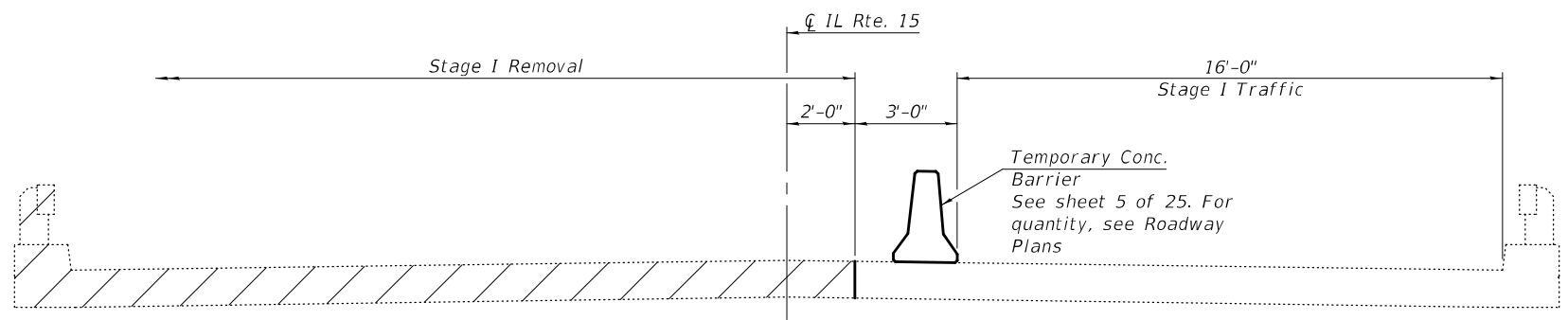

**STAGE I REMOVAL**  
(Looking East)

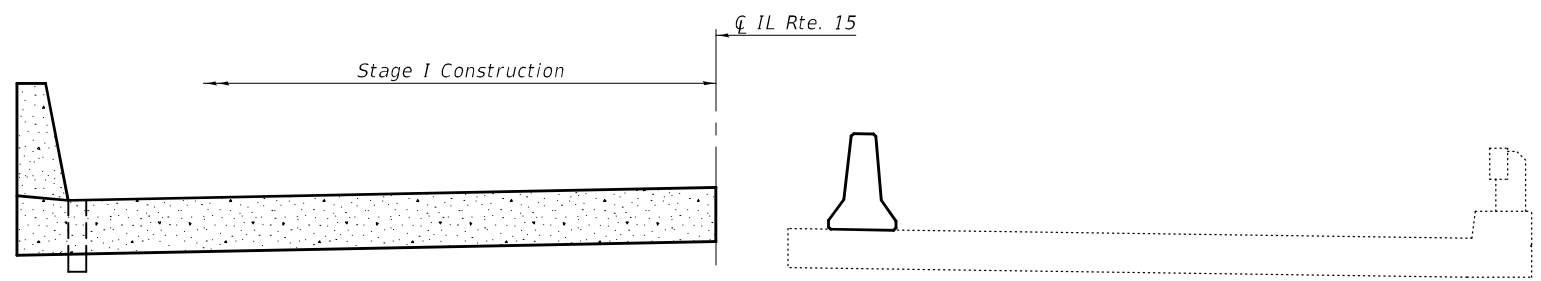

**STAGE I CONSTRUCTION**  
(Looking East)

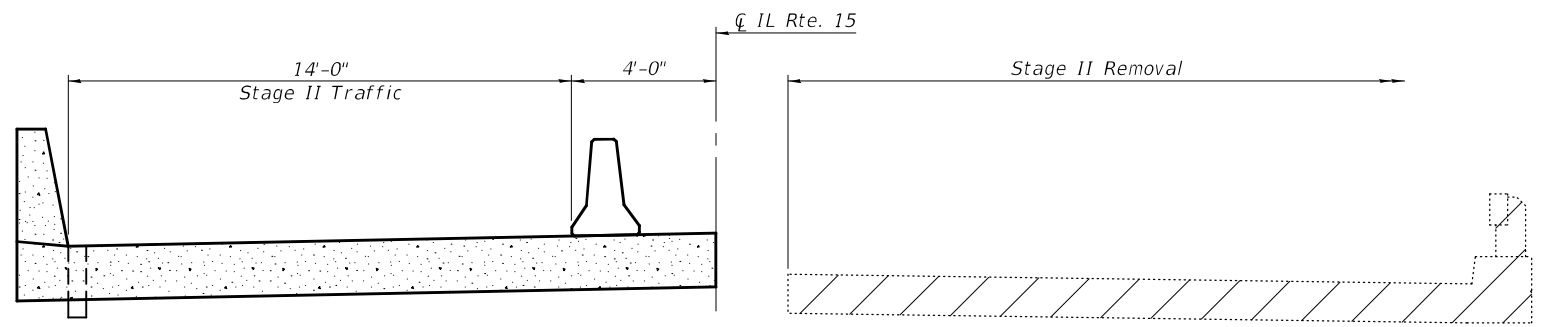

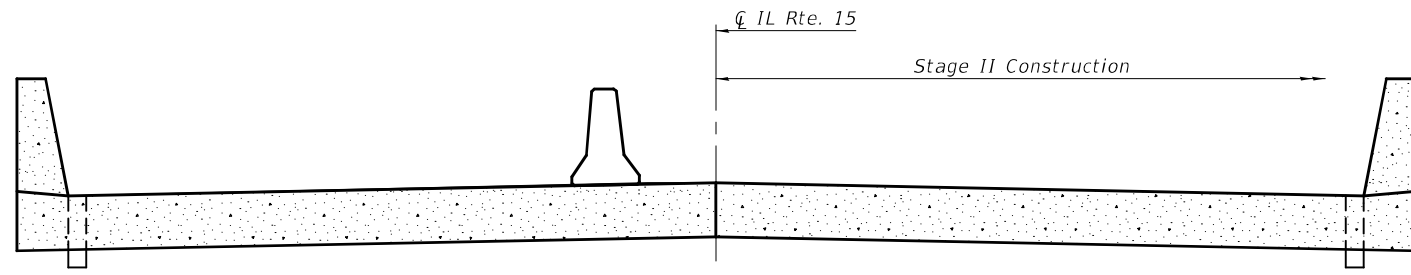

**STAGE II REMOVAL**  
(Looking East)



**STAGE II CONSTRUCTION**  
(Looking East)

MODEL: 0960076-74651-018  
 FILE NAME: pw:\tdot\pw\benley.com\FWIDOT\Documents\DOT\_Offices\Bureau of Bridges and Structures\Projects\0960076\CADD Plans\0960076-74651

DESIGNED	-	HAMEED S. SALIH
CHECKED	-	PAUL S. JOHNSON
DRAWN	-	ANTHONY J. NOVELLO
CHECKED	-	HSS / PSJ

EXAMINED	
PASSED	

DATE	-	APRIL 26, 2023
REVISED	-	___
REVISED	-	___

**STATE OF ILLINOIS**  
**DEPARTMENT OF TRANSPORTATION**

<b>STAGE CONSTRUCTION DETAILS</b> <b>STRUCTURE NO. 096-0076</b>	
SHEET 3 OF 25 SHEETS	

F.A.P. RTE.	SECTION	COUNTY	TOTAL SHEETS	SHEET NO.
821	(18BY)B	WAYNE	53	18
CONTRACT NO. 74651				
ILLINOIS			FED. AID PROJECT	

5/8/2023 11:24:12 AM

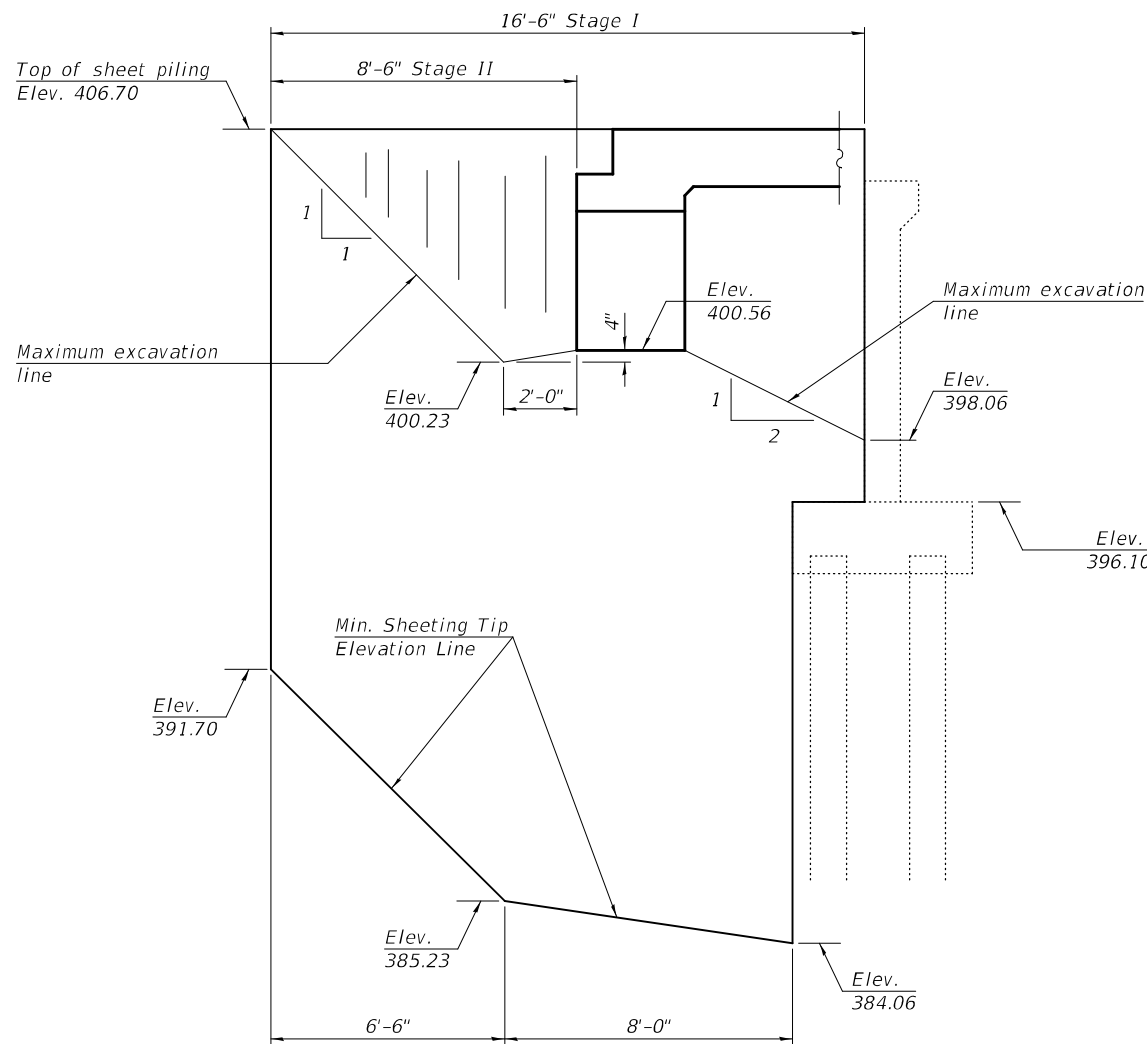

**WEST ABUTMENT  
TEMPORARY SHEET PILING**  
Minimum section modulus = 19 in.<sup>3</sup>/ft.

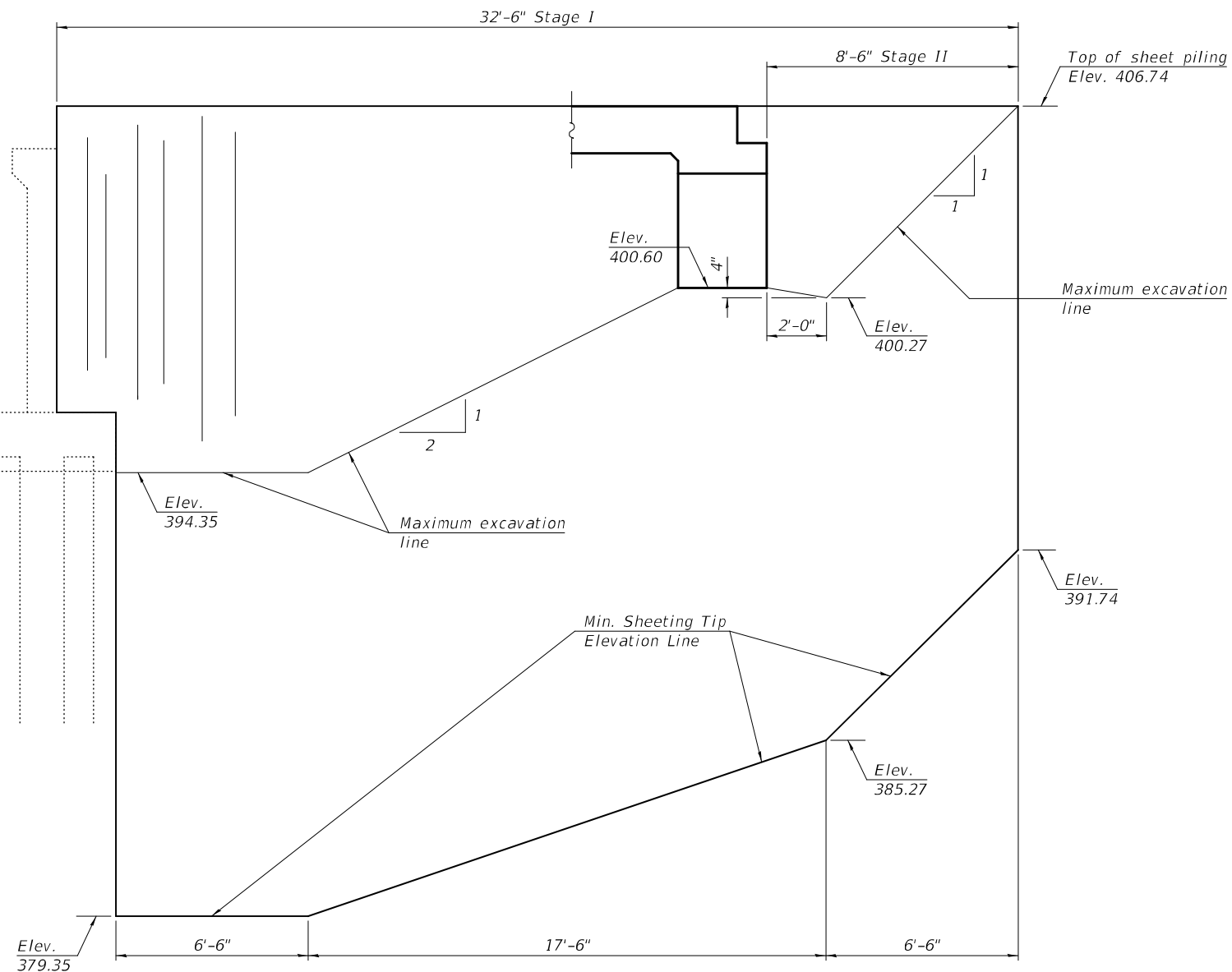

**EAST ABUTMENT  
TEMPORARY SHEET PILING**  
Minimum section modulus = 19 in.<sup>3</sup>/ft.

If the Contractor chooses to alter the temporary cantilevered sheet piling design requirements shown on the plans, a design submittal including plan details and calculations will be required for review and acceptance by the Engineer.

The Contractor shall connect the first sheet to the existing abutment wall to ensure stability of sheets driven to the top of the existing footing. This connection shall be reviewed and accepted by the Engineer and included in the cost for Temporary Sheet Piling.

MODEL: 0960076-74651-019  
FILE NAME: p:\w\id\spw\benley.com\FWIDOT\Documents\DOT Offices\Bureau of Bridges and Structures\Projects\0960076\CADD Plans\0960076-74651

DESIGNED -	HAMEED S. SALIH
CHECKED -	PAUL S. JOHNSON
DRAWN -	ANTHONY J. NOVELLO
CHECKED -	HSS / PSJ

EXAMINED  
PASSED

*Mark Shuffin*  
ENGINEER OF BRIDGE DESIGN  
*James F. [Signature]*  
ENGINEER OF BRIDGES AND STRUCTURES

DATE - APRIL 26, 2023

REVISED -  
REVISED -

STATE OF ILLINOIS  
DEPARTMENT OF TRANSPORTATION

TEMPORARY SHEET PILING  
STRUCTURE NO. 096-0076

SHEET 4 OF 25 SHEETS

F.A.P. RTE.	SECTION	COUNTY	TOTAL SHEETS	SHEET NO.
821	(18BY)B	WAYNE	53	19
CONTRACT NO. 74651				
ILLINOIS FED. AID PROJECT				

5/8/2023 11:25:23 AM

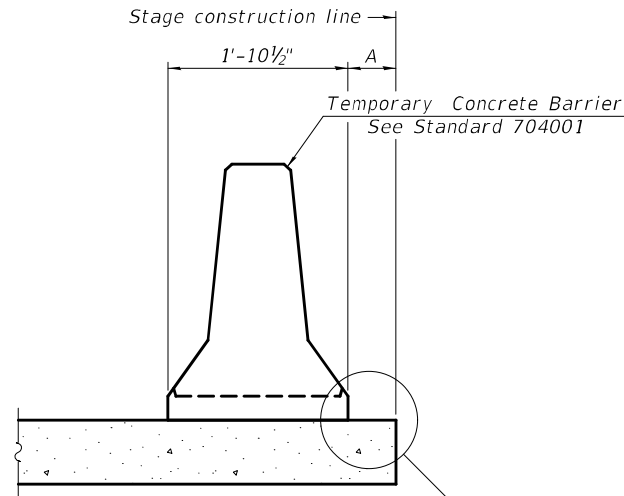

When "A" is 3'-1" or less, the temporary concrete barrier shall be restrained to the new slab according to Detail I, II or III. No restraint is required when "A" is greater than 3'-1".

NEW SLAB OR NEW DECK BEAM

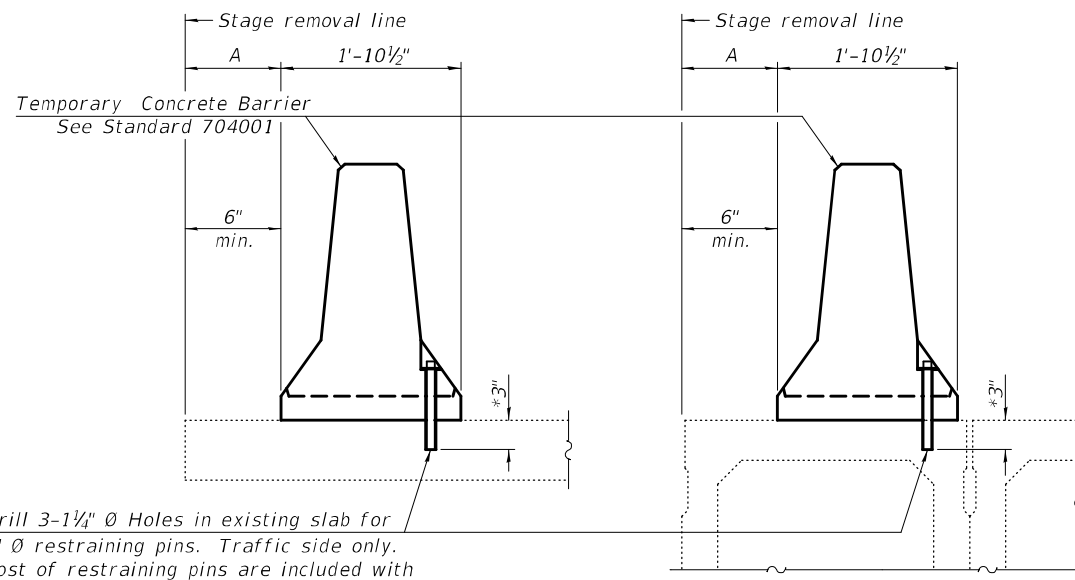

Drill 3-1/4" Ø Holes in existing slab for 1" Ø restraining pins. Traffic side only. Cost of restraining pins are included with Temporary Concrete Barrier. No restraint is required when "A" is greater than 3'-1".

EXISTING SLAB

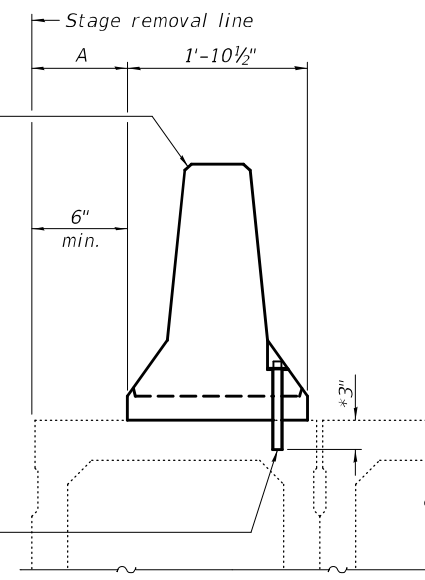

\* When hot-mix asphalt wearing surface is present, embedment shall be 3" plus the wearing surface depth.

EXISTING DECK BEAM

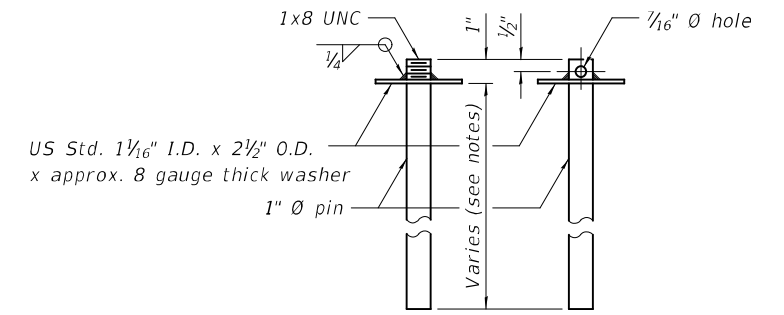

RESTRAINING PIN

SECTIONS THRU SLAB OR DECK BEAM

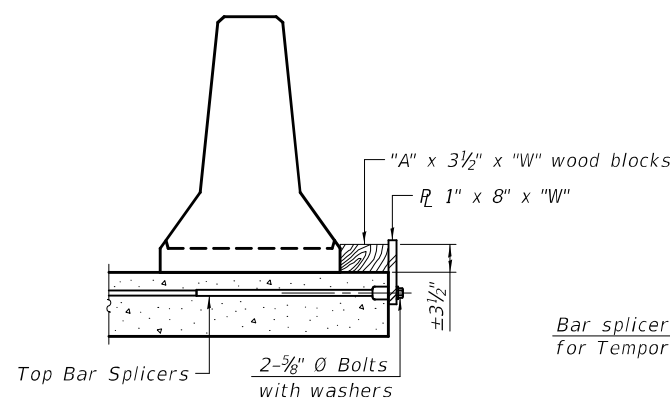

DETAIL I

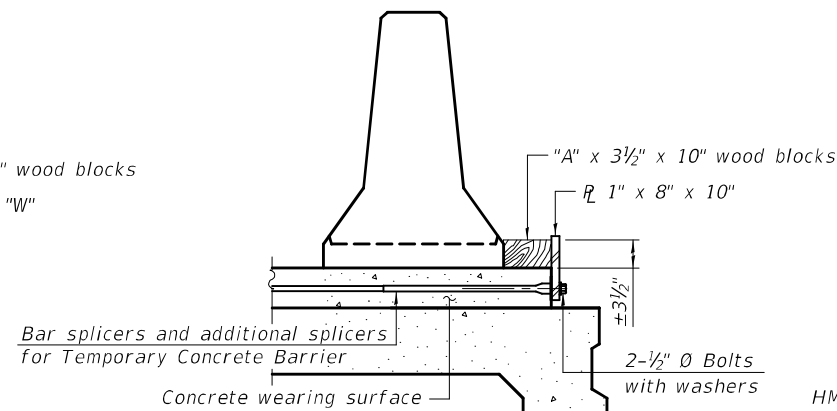

DETAIL II

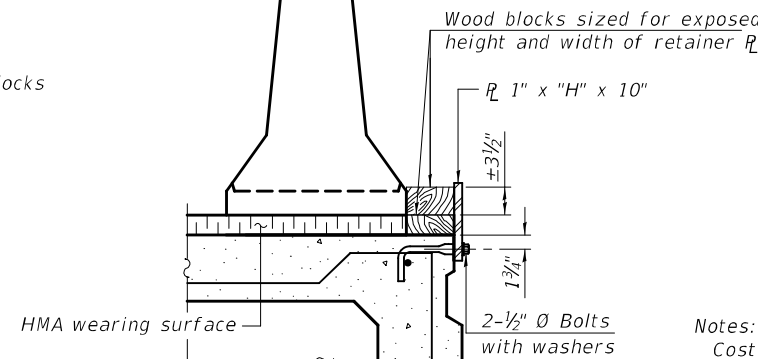

DETAIL III

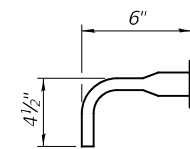

BAR SPLICER FOR #4 BAR - DETAIL III

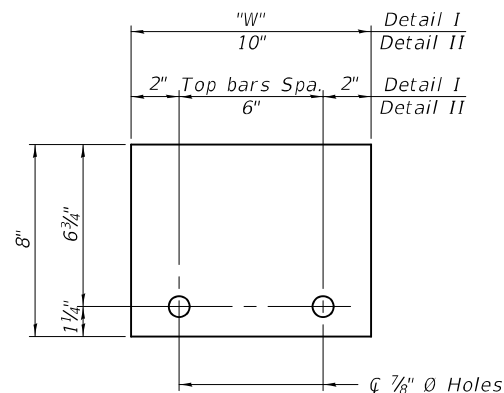

STEEL RETAINER R 1" x 8" x "W" (Detail I and II)

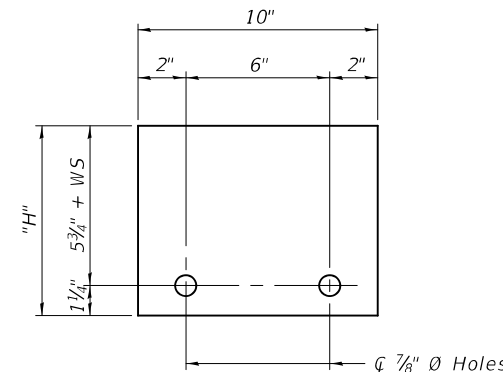

STEEL RETAINER R 1" x "H" x 10" (Detail III)

Notes:  
 Cost of retainer assembly is included with Temporary Concrete Barrier.  
 A retainer assembly shall be located at the approximate center of each temporary concrete barrier.  
 The retainer plate shall not be removed until the concrete on the adjacent stage is ready to be poured. For Detail III applications the retainer plate shall not be removed until just prior to placing the adjacent beam.  
 When the 'A' dimension is less than 1 1/2', the wood block shall be omitted and the barrier shall be placed in direct contact with the steel retainer plate. For deck beam applications the minimum required 'A' distance is 6' to accommodate the shear key clamping device.

Detail I - Installation for a new bridge deck or bridge slab.  
 Detail II - Installation for a new deck beam with an initial concrete wearing surface. Additional bar splicers shall be provided at 6'-0" centers and paired with the bar splicers of the concrete wearing surface reinforcement to accommodate the installation of the retainer assemblies. The cost of the additional bar splicers is included with the concrete wearing surface.  
 Detail III - Installation for a new deck beam with no initial wearing surface or with an initial hot-mix asphalt (HMA) wearing surface present. The deck beam directly beneath the temporary concrete barrier shall be fabricated with bar splicer inserts in the side of the beam, as detailed, to accommodate the installation of the retainer assemblies. A pair of bar splicers, 6" apart, shall be placed at 6'-0" centers along the length of the beam. The cost of the bar splicers is included with the deck beam.

RAILING CRITERIA

NCHRP 350 Test Level	3
Railing Weight (plf)	440

R-27 10-12-2021

MODEL: 0960076-74651-020  
 FILE NAME: p:\w\p\w\benley.com\FWIDOT\Documents\DOT Offices\Bureau of Bridges and Structures\Projects\0960076\CADD Plans\0960076-74651

DESIGNED - HAMEED S. SALIH	EXAMINED
CHECKED - PAUL S. JOHNSON	PASSED
DRAWN - ANTHONY J. NOVELLO	
CHECKED - HSS / PSJ	

DATE - APRIL 26, 2023  
 Mark Shuffler  
 ENGINEER OF BRIDGE DESIGN  
 Jayne F. [Signature]  
 ENGINEER OF BRIDGES AND STRUCTURES

REVISD -	
REVISD -	

STATE OF ILLINOIS  
 DEPARTMENT OF TRANSPORTATION

TEMPORARY CONCRETE BARRIER FOR STAGE CONSTRUCTION  
 STRUCTURE NO. 096-0076

SHEET 5 OF 25 SHEETS

F.A.P. RTE. 821	SECTION (18BY)B	COUNTY WAYNE	TOTAL SHEETS 53	SHEET NO. 20
CONTRACT NO. 74651				
ILLINOIS FED. AID PROJECT				

5/8/2023 11:25:50 AM

MODEL: 0960076-74651-021  
 FILE NAME: p:\w\p\w\benley.com\FWIDOT\Documents\DOT Offices\Bureau of Bridges and Structures\Projects\0960076\CADD Plans\0960076-74651

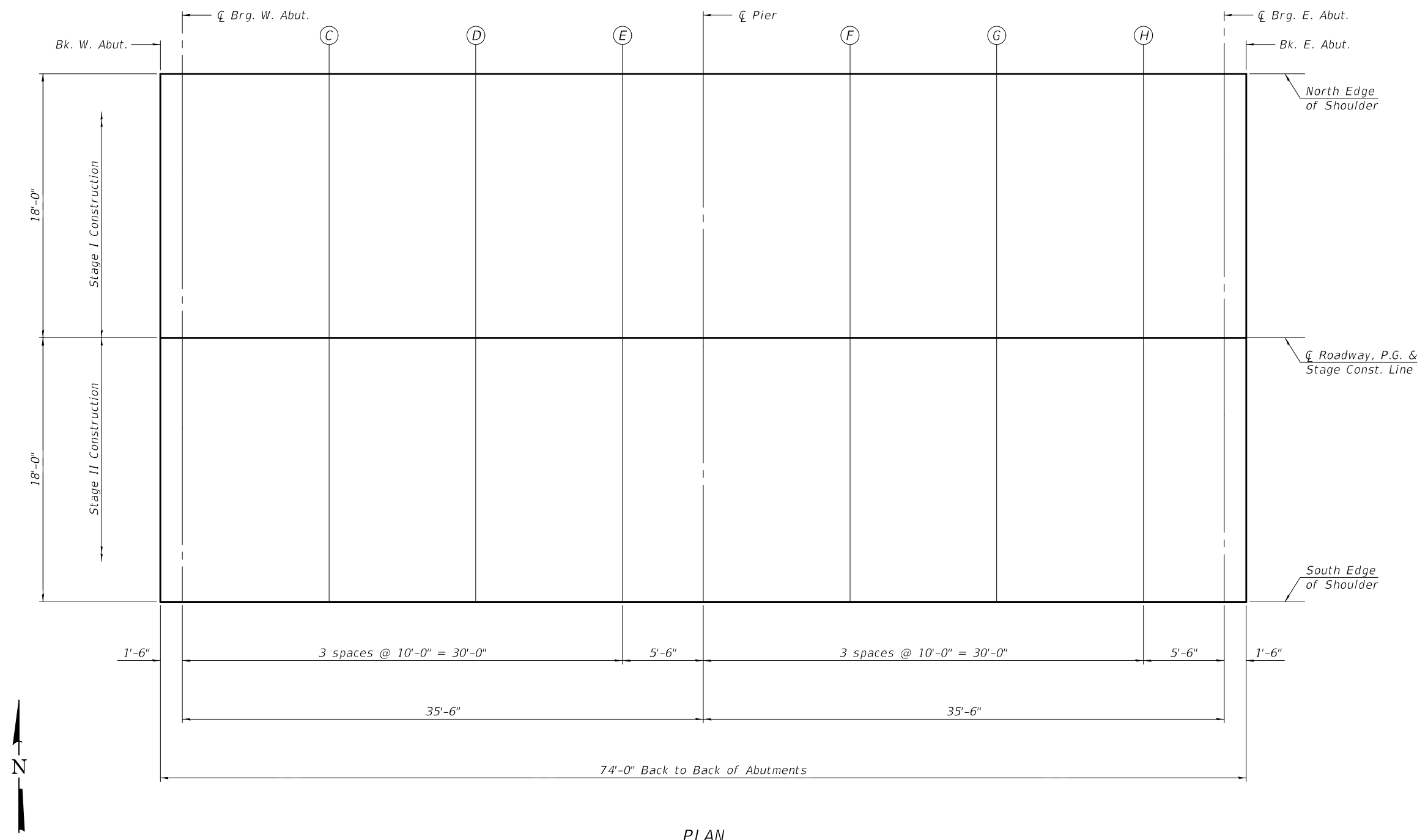

PLAN

DESIGNED - HAMEED S. SALIH	EXAMINED - <i>Mark Shuffin</i>
CHECKED - PAUL S. JOHNSON	PASSED - <i>Jaime F. [Signature]</i>
DRAWN - ANTHONY J. NOVELLO	
CHECKED - HSS / PSJ	

DATE - APRIL 26, 2023	REVISED -
	REVISED -

STATE OF ILLINOIS  
 DEPARTMENT OF TRANSPORTATION

TOP OF SLAB ELEVATIONS	
STRUCTURE NO. 096-0076	
SHEET 6 OF 25 SHEETS	

F.A.P. RTE. 821	SECTION (18BY)B	COUNTY WAYNE	TOTAL SHEETS 53	SHEET NO. 21
ILLINOIS			FED. AID PROJECT	

CONTRACT NO. 74651

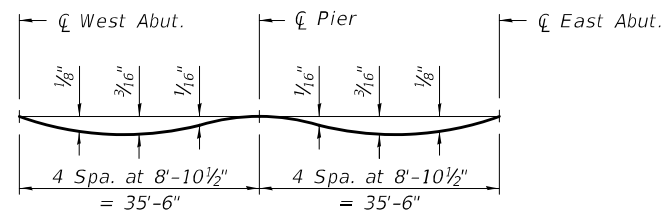

**DEAD LOAD DEFLECTION DIAGRAM**

(Includes weight of concrete only.)

**Note:**

The above deflections are not to be used in the field if the engineer is working from the grade elevations adjusted for dead load deflections as shown below.

**NORTH EDGE OF SHOULDER**

Location	Station	Offset	Theoretical Grade Elevations	Theoretical Grade Elevations Adjusted For Dead Load Deflection
Bk. W. Abut.	1098+13.00	-18.00	406.34	406.34
☒ Brg. W. Abut.	1098+14.50	-18.00	406.34	406.34
C	1098+24.50	-18.00	406.36	406.37
D	1098+34.50	-18.00	406.37	406.38
E	1098+44.50	-18.00	406.38	406.38
☒ Pier	1098+50.00	-18.00	406.38	406.38
F	1098+60.00	-18.00	406.39	406.39
G	1098+70.00	-18.00	406.39	406.40
H	1098+80.00	-18.00	406.38	406.39
☒ Brg. E. Abut.	1098+85.50	-18.00	406.38	406.38
Bk. E. Abut.	1098+87.00	-18.00	406.38	406.38

**☒ ROADWAY, PG & STAGE CONSTRUCTION LINE**

Location	Station	Offset	Theoretical Grade Elevations	Theoretical Grade Elevations Adjusted For Dead Load Deflection
Bk. W. Abut.	1098+13.00	0.00	406.70	406.70
☒ Brg. W. Abut.	1098+14.50	0.00	406.70	406.70
C	1098+24.50	0.00	406.72	406.73
D	1098+34.50	0.00	406.73	406.74
E	1098+44.50	0.00	406.74	406.74
☒ Pier	1098+50.00	0.00	406.74	406.74
F	1098+60.00	0.00	406.75	406.75
G	1098+70.00	0.00	406.75	406.76
H	1098+80.00	0.00	406.74	406.75
☒ Brg. E. Abut.	1098+85.50	0.00	406.74	406.74
Bk. E. Abut.	1098+87.00	0.00	406.74	406.74

**SOUTH EDGE OF SHOULDER**

Location	Station	Offset	Theoretical Grade Elevations	Theoretical Grade Elevations Adjusted For Dead Load Deflection
Bk. W. Abut.	1098+13.00	18.00	406.34	406.34
☒ Brg. W. Abut.	1098+14.50	18.00	406.34	406.34
C	1098+24.50	18.00	406.36	406.37
D	1098+34.50	18.00	406.37	406.38
E	1098+44.50	18.00	406.38	406.38
☒ Pier	1098+50.00	18.00	406.38	406.38
F	1098+60.00	18.00	406.39	406.39
G	1098+70.00	18.00	406.39	406.40
H	1098+80.00	18.00	406.38	406.39
☒ Brg. E. Abut.	1098+85.50	18.00	406.38	406.38
Bk. E. Abut.	1098+87.00	18.00	406.38	406.38

MODEL: 0960076-74651-022  
FILE NAME: p:\w\idol-pw\benley.com\FWIDOT\Documents\IDOT Offices\Bureau of Bridges and Structures\Projects\0960076\CADD Plans\0960076-74651

E-S 2-17-2017

DESIGNED - HAMEED S. SALIH	EXAMINED
CHECKED - PAUL S. JOHNSON	PASSED
DRAWN - ANTHONY J. NOVELLO	
CHECKED - HSS / PSJ	

DATE - APRIL 26, 2023  
  
 ENGINEER OF BRIDGE DESIGN  
  
 ENGINEER OF BRIDGES AND STRUCTURES

REVISD -	
REVISD -	

STATE OF ILLINOIS  
DEPARTMENT OF TRANSPORTATION

TOP OF SLAB ELEVATIONS  
STRUCTURE NO. 096-0076

SHEET 7 OF 25 SHEETS

F.A.P. RTE.	SECTION	COUNTY	TOTAL SHEETS	SHEET NO.
821	(18BY)B	WAYNE	53	22
ILLINOIS			FED. AID PROJECT	
CONTRACT NO. 74651				

NORTH EDGE OF SHOULDER

Location	Station	Offset	Theoretical Grade Elevations
W. End of W. Appr. Slab	1097+84.00	-18.00	406.27
A	1097+94.00	-18.00	406.30
B	1098+04.00	-18.00	406.32
E. End of W. Appr. Slab	1098+14.00	-18.00	406.34

CL ROADWAY, PG & STAGE CONSTRUCTION LINE

Location	Station	Offset	Theoretical Grade Elevations
W. End of W. Appr. Slab	1097+84.00	0.00	406.63
A	1097+94.00	0.00	406.66
B	1098+04.00	0.00	406.68
E. End of W. Appr. Slab	1098+14.00	0.00	406.70

SOUTH EDGE OF SHOULDER

Location	Station	Offset	Theoretical Grade Elevations
W. End of W. Appr. Slab	1097+84.00	18.00	406.27
A	1097+94.00	18.00	406.30
B	1098+04.00	18.00	406.32
E. End of W. Appr. Slab	1098+14.00	18.00	406.34

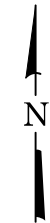
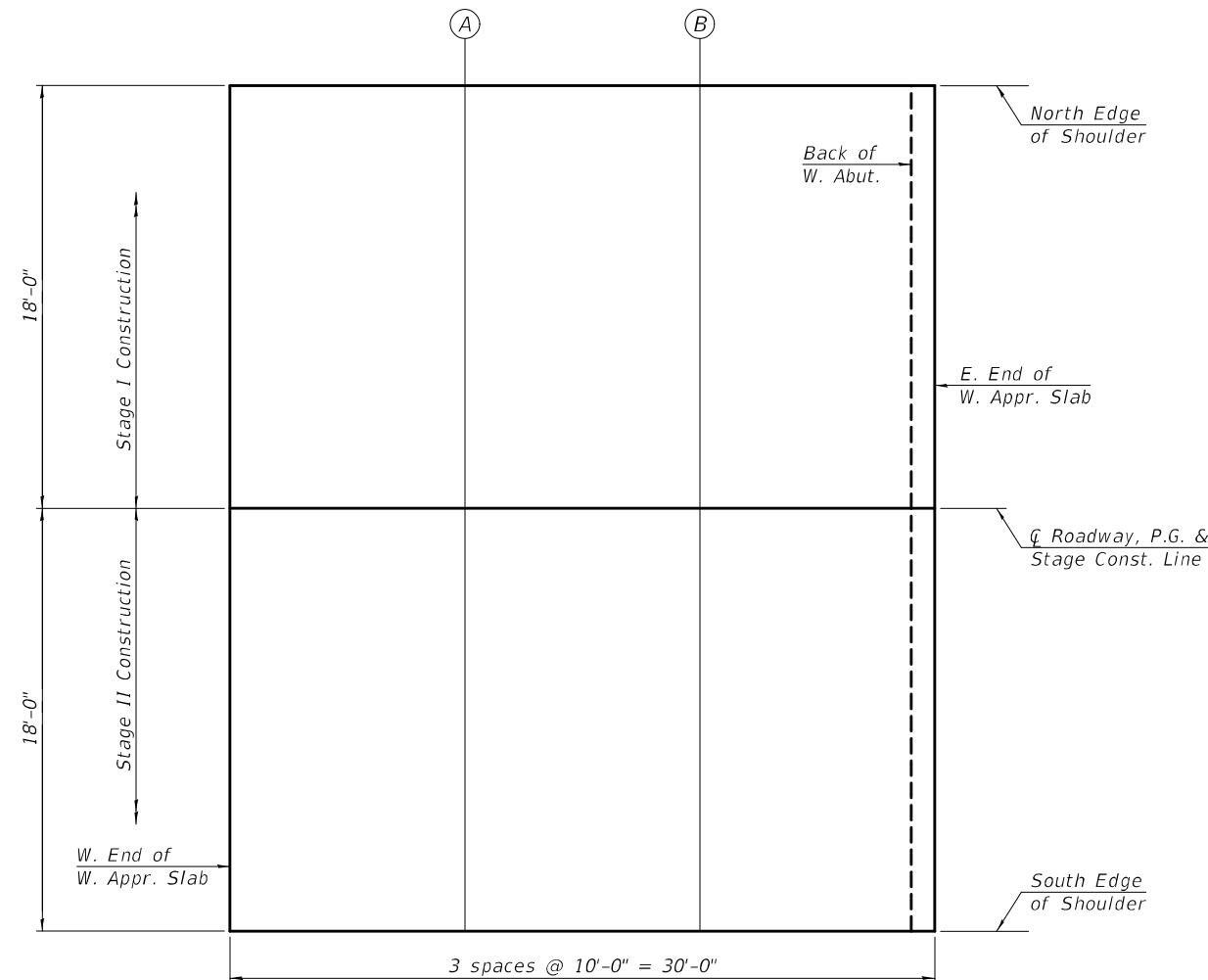

MODEL: 0960076-74651-023  
FILE NAME: p:\w\p\w\benley.com\FWIDOT\Documents\DOT Offices\Bureau of Bridges and Structures\Projects\0960076\CADD Plans\0960076-74651

DESIGNED - HAMEED, S. SALIH	EXAMINED
CHECKED - PAUL S. JOHNSON	PASSED
DRAWN - ANTHONY J. NOVELLO	
CHECKED - HSS / PSJ	

DATE - APRIL 26, 2023

*Mark Shuffin*  
ENGINEER OF BRIDGE DESIGN

*Jayne F. Hoff*  
ENGINEER OF BRIDGES AND STRUCTURES

REVISED -	
REVISED -	

STATE OF ILLINOIS  
DEPARTMENT OF TRANSPORTATION

TOP OF WEST APPROACH SLAB ELEVATIONS  
STRUCTURE NO. 096-0076

SHEET 8 OF 25 SHEETS

F.A.P. RTE. 821	SECTION (18BY)B	COUNTY WAYNE	TOTAL SHEETS 53	SHEET NO. 23
ILLINOIS FED. AID PROJECT			CONTRACT NO. 74651	

NORTH EDGE OF SHOULDER

Location	Station	Offset	Theoretical Grade Elevations
W. End of E. Appr. Slab	1098+86.00	-18.00	406.38
I	1098+96.00	-18.00	406.37
J	1099+06.00	-18.00	406.35
E. End of E. Appr. Slab	1099+16.00	-18.00	406.34

CL ROADWAY, PG & STAGE CONSTRUCTION LINE

Location	Station	Offset	Theoretical Grade Elevations
W. End of E. Appr. Slab	1098+86.00	0.00	406.74
I	1098+96.00	0.00	406.73
J	1099+06.00	0.00	406.71
E. End of E. Appr. Slab	1099+16.00	0.00	406.70

SOUTH EDGE OF SHOULDER

Location	Station	Offset	Theoretical Grade Elevations
W. End of E. Appr. Slab	1098+86.00	18.00	406.38
I	1098+96.00	18.00	406.37
J	1099+06.00	18.00	406.35
E. End of E. Appr. Slab	1099+16.00	18.00	406.34

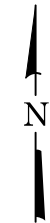
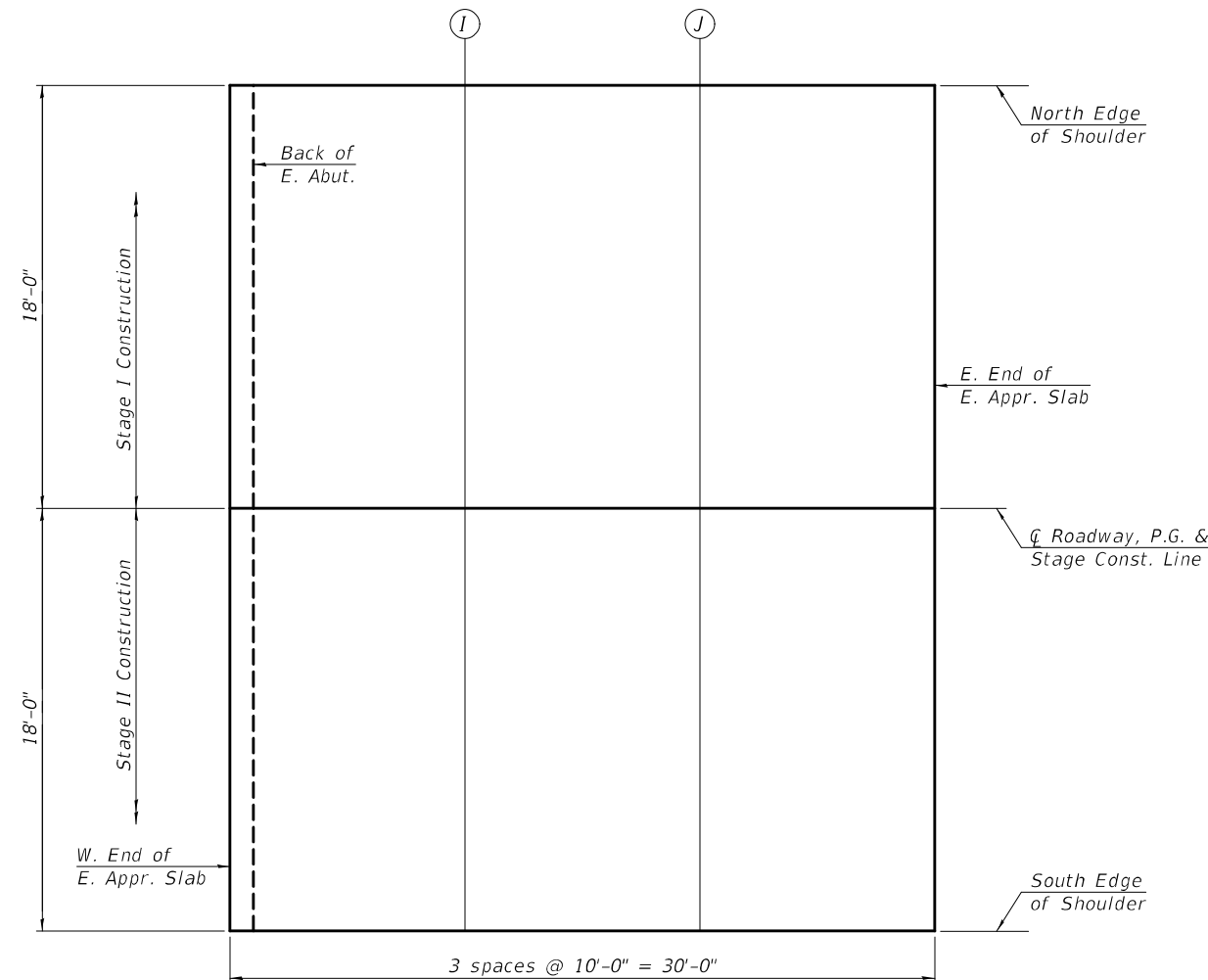

MODEL: 0960076-74651-024  
FILE NAME: p:\w\id\p\w\benley.com\FWIDOT\Documents\DOT Offices\Bureau of Bridges and Structures\Projects\0960076\CADD Plans\0960076-74651

DESIGNED - HAMEED S. SALIH	EXAMINED - <i>Mark Shuffin</i> ENGINEER OF BRIDGE DESIGN	DATE - APRIL 26, 2023
CHECKED - PAUL S. JOHNSON	PASSED - <i>Jaime F. [Signature]</i> ENGINEER OF BRIDGES AND STRUCTURES	REVISED - _____
DRAWN - ANTHONY J. NOVELLO		REVISED - _____
CHECKED - HSS / PSJ		

STATE OF ILLINOIS  
DEPARTMENT OF TRANSPORTATION

TOP OF EAST APPROACH SLAB ELEVATIONS  
STRUCTURE NO. 096-0076

SHEET 9 OF 25 SHEETS

F.A.P. RTE. 821	SECTION (18BY)B	COUNTY WAYNE	TOTAL SHEETS 53	SHEET NO. 24
			CONTRACT NO. 74651	
		ILLINOIS	FED. AID PROJECT	



MODEL: 0960076-74651-025  
 FILE NAME: p:\w\idol-ppw\benley.com\FWIDOT\Documents\IDOT Offices\Bureau of Bridges and Structures\Projects\0960076\CADD Plans\0960076-74651

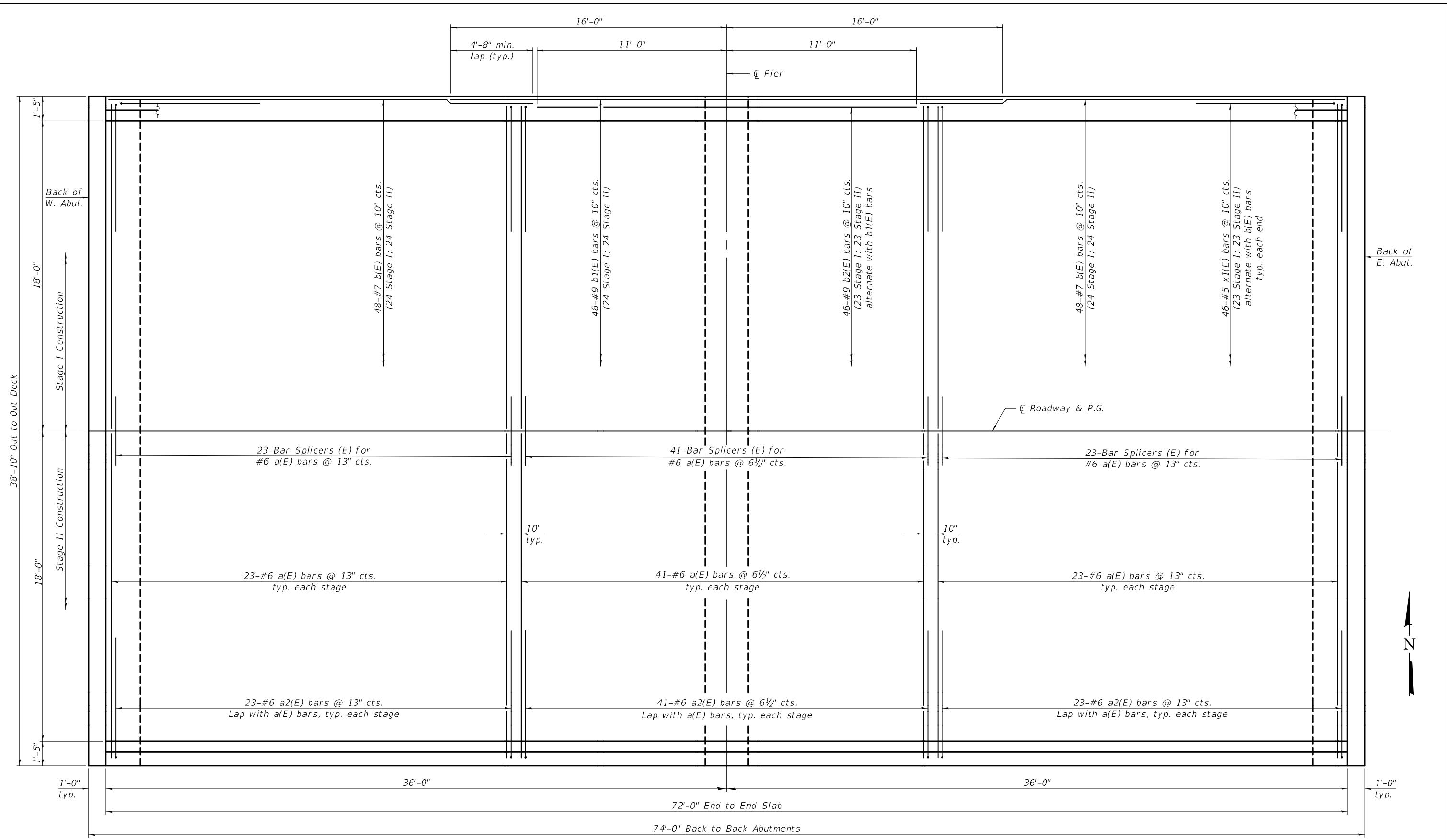

**PLAN**  
 (Showing Top Reinforcement)

Note:  
 See sheets 12 & 13 of 25  
 for Superstructure Details  
 and Bill of Material.

DESIGNED - HAMEED S. SALIH	EXAMINED - <i>Mark Shuffan</i> ENGINEER OF BRIDGE DESIGN	DATE - APRIL 26, 2023	<b>STATE OF ILLINOIS DEPARTMENT OF TRANSPORTATION</b>	<b>SUPERSTRUCTURE STRUCTURE NO. 096-0076</b>	F.A.P. RTE. 821	SECTION (18BY)B	COUNTY WAYNE	TOTAL SHEETS 53	SHEET NO. 25	
CHECKED - PAUL S. JOHNSON	PASSED - <i>Joanne F. DeLoe</i> ENGINEER OF BRIDGES AND STRUCTURES	REVISED -			CONTRACT NO. 74651					
DRAWN - ANTHONY J. NOVELLO		REVISED -			SHEET 10 OF 25 SHEETS					
CHECKED - HSS / PSJ			ILLINOIS FED. AID PROJECT							

MODEL: 0960076-74651-026  
 FILE NAME: p:\w\lido-ppw-bentley.com\FW\DOT\Documents\DOT Offices\Bureau of Bridges and Structures\Projects\0960076\CADD Plans\0960076-74651

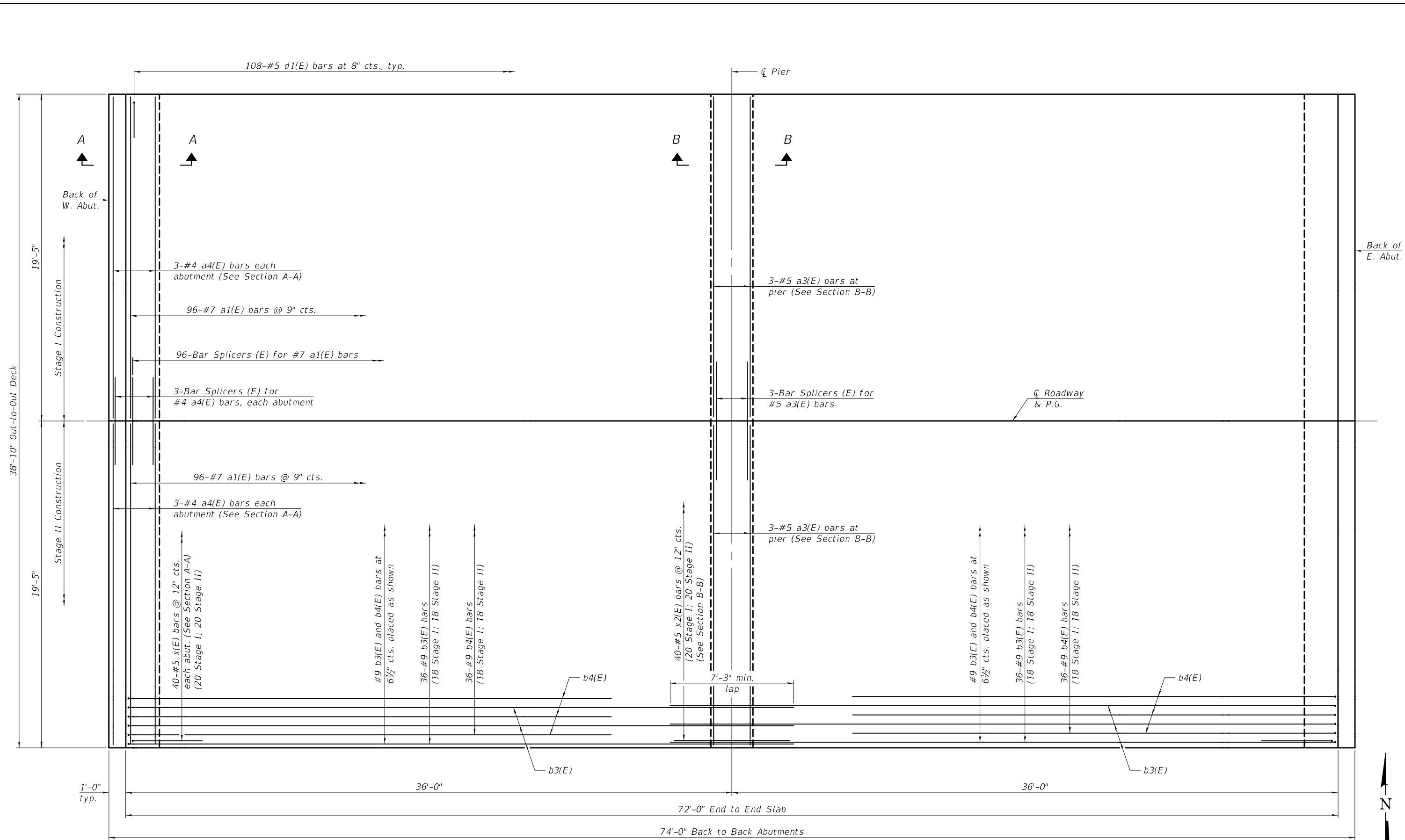

**PLAN**  
 (Showing Bottom Reinforcement)

DESIGNED -	HAMEED S. SALIH
CHECKED -	PAUL S. JOHNSON
DRAWN -	ANTHONY J. NOVELLO
CHECKED -	HSS / PSJ

EXAMINED	<i>Mark Shuffler</i> ENGINEER OF BRIDGE DESIGN
PASSED	<i>James F. [Signature]</i> ENGINEER OF BRIDGES AND STRUCTURES

DATE -	APRIL 26, 2023
REVISED -	---
REVISED -	---

STATE OF ILLINOIS  
 DEPARTMENT OF TRANSPORTATION

**SUPERSTRUCTURE**  
**STRUCTURE NO. 096-0076**

SHEET 11 OF 25 SHEETS

F.A.P. RTE.	SECTION	COUNTY	TOTAL SHEETS	SHEET NO.
821	(18BY)B	WAYNE	53	26
CONTRACT NO. 74651				
ILLINOIS FED. AID PROJECT				

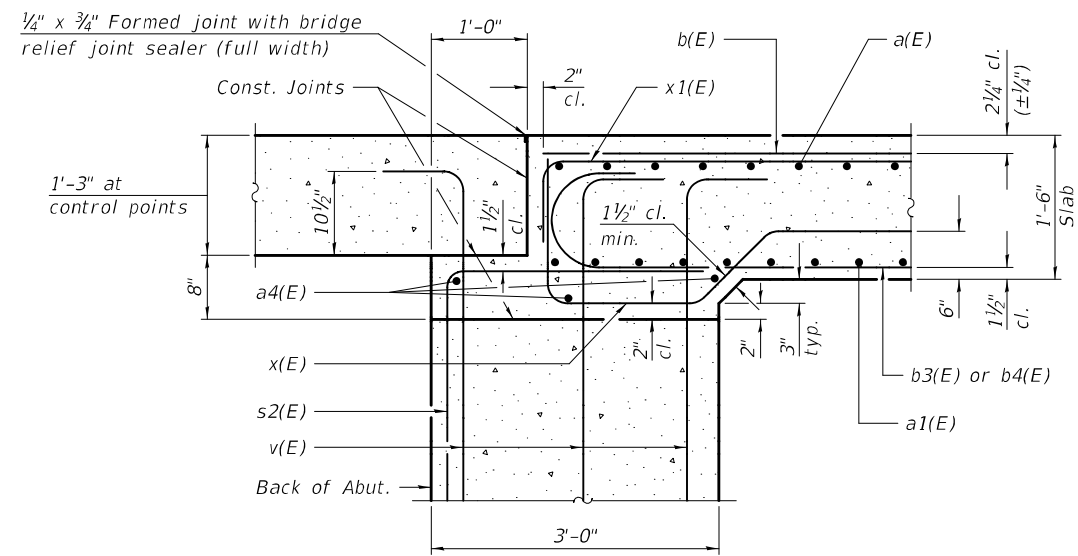
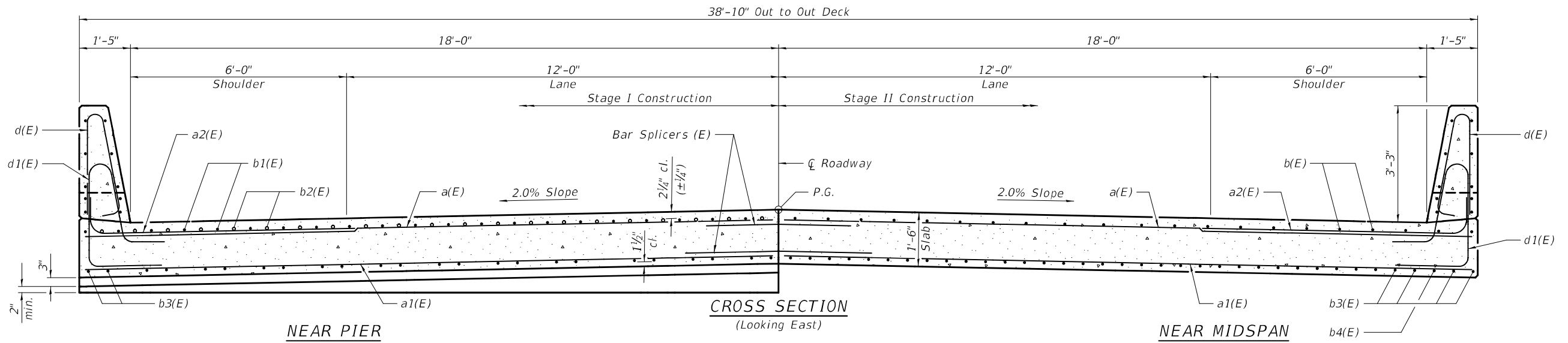

SECTION A-A

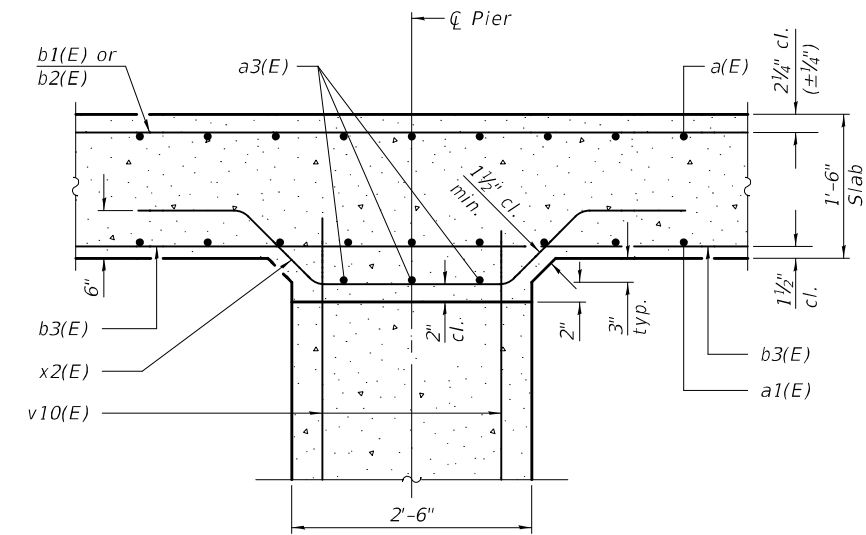

SECTION B-B

Note:  
See sheet 13 of 25 for  
Superstructure Details and  
Bill of Material.

MODEL: 0960076-74651-027  
FILE NAME: p:\w\idol-ppw\benley.com\FWIDOT\Documents\Bridges and Structures\Projects\0960076\CADD Plans\0960076-74651

DESIGNED -	HAMEED S. SALIH
CHECKED -	PAUL S. JOHNSON
DRAWN -	ANTHONY J. NOVELLO
CHECKED -	HSS / PSJ

EXAMINED	<i>Mark Shuffler</i> ENGINEER OF BRIDGE DESIGN
PASSED	<i>James F. ...</i> ENGINEER OF BRIDGES AND STRUCTURES

DATE -	APRIL 26, 2023
REVISED -	---
REVISED -	---

STATE OF ILLINOIS  
DEPARTMENT OF TRANSPORTATION

SUPERSTRUCTURE  
STRUCTURE NO. 096-0076

SHEET 12 OF 25 SHEETS

F.A.P. RTE.	SECTION	COUNTY	TOTAL SHEETS	SHEET NO.
821	(18BY)B	WAYNE	53	27
CONTRACT NO. 74651				
ILLINOIS		FED. AID PROJECT		

5/8/2023 11:29:01 AM

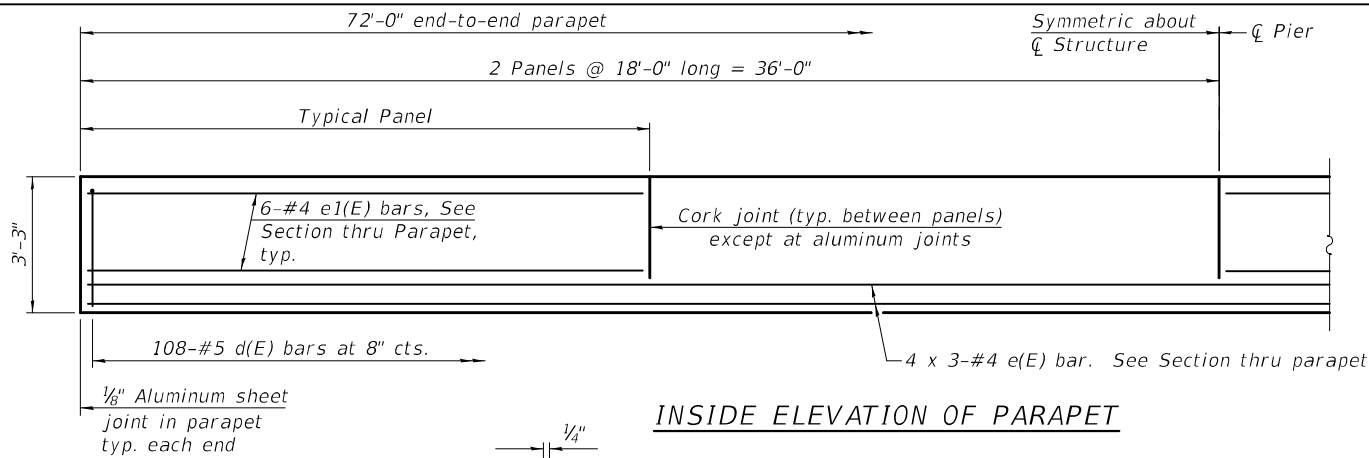

**MINIMUM BAR LAP**

#4 bar = 2'-5"

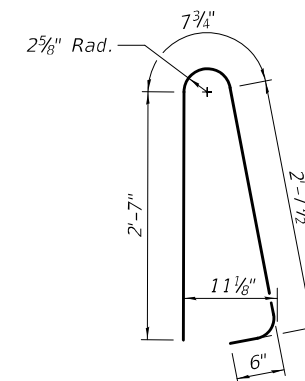

**BAR d(E)**

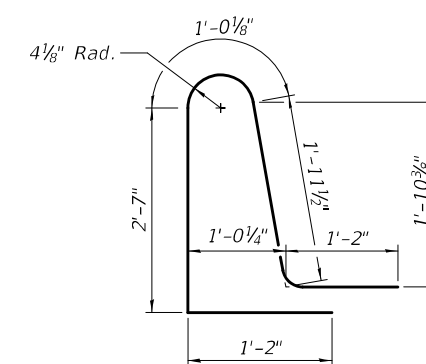

**BAR d1(E)**

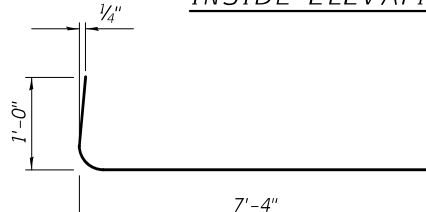

**BAR a2(E)**

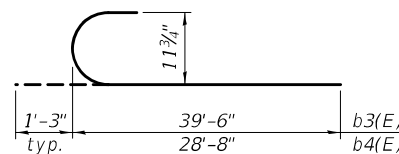

**BAR b3(E) / BAR b4(E)**

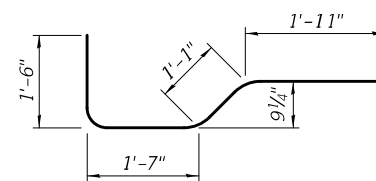

**BAR x(E)**

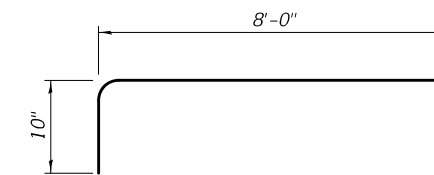

**BAR x1(E)**

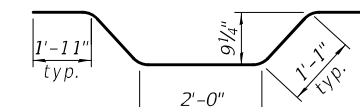

**BAR x2(E)**

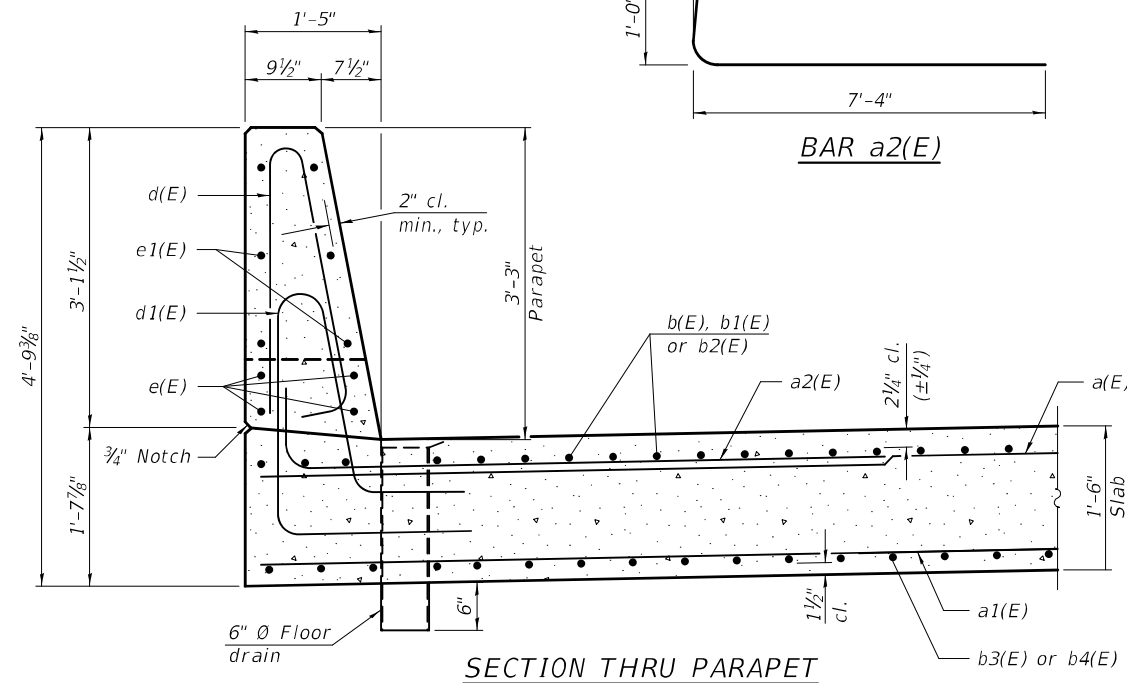

**SECTION THRU PARAPET**

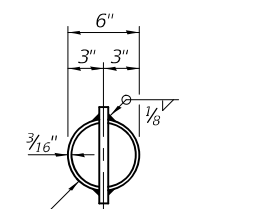

6" O.D. Aluminum tube alloy 6061-T6 or 6"  $\bar{\phi}$  fiberglass pipe

**TOP PLAN**

(Showing aluminum tube)

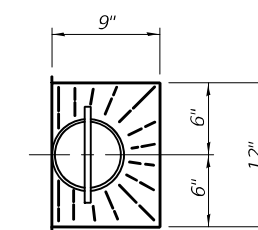

**TOP PLAN**

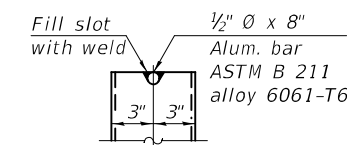

**ALUMINUM TUBE**

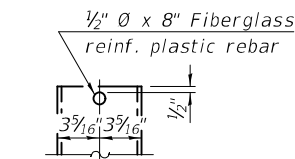

**FIBERGLASS PIPE**

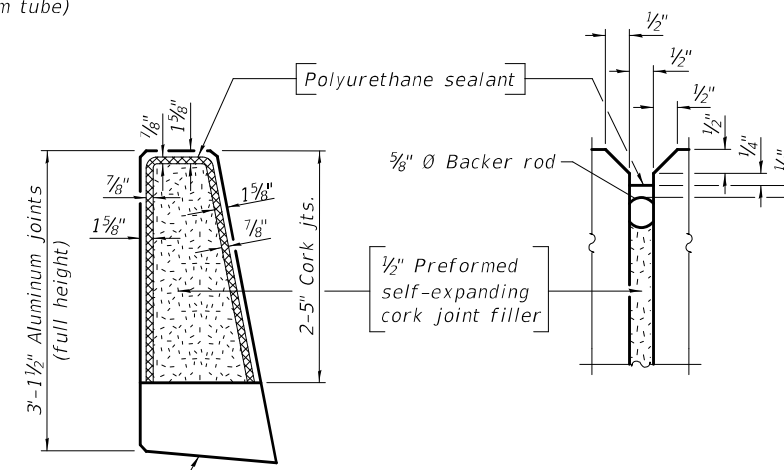

**PARAPET JOINT DETAILS**

**SUPERSTRUCTURE BILL OF MATERIAL**

Bar	No.	Size	Length	Shape
a(E)	174	#6	19'-1"	—
a1(E)	192	#7	19'-1"	—
a2(E)	174	#6	8'-4"	—
a3(E)	6	#5	19'-1"	—
a4(E)	12	#4	19'-1"	—
b(E)	96	#7	24'-7"	—
b1(E)	48	#9	32'-0"	—
b2(E)	46	#9	22'-0"	—
b3(E)	72	#9	40'-9"	—
b4(E)	72	#9	29'-11"	—
d(E)	216	#5	6'-5"	—
d1(E)	216	#5	7'-11"	—
e(E)	24	#4	25'-6"	—
e1(E)	48	#4	17'-8"	—
x(E)	80	#5	6'-1"	—
x1(E)	92	#5	8'-10"	—
x2(E)	40	#5	8'-0"	—
Reinforcement Bars, Epoxy Coated			Pound	51,610
Concrete Superstructure			Cu. Yd.	180.6

Bars indicated thus 4 x 3-#4 etc. indicates 4 lines of bars with 3 lengths per line.

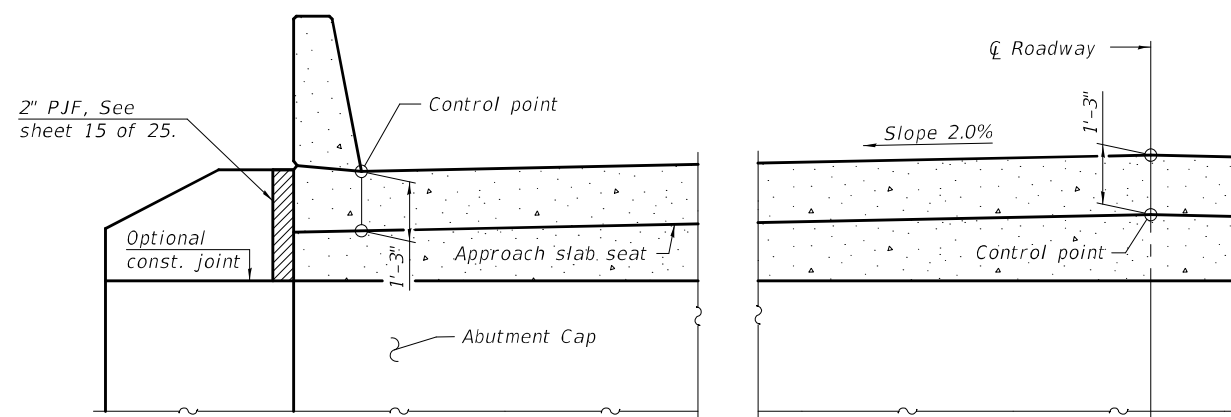

**APPROACH SLAB SEAT**

**Notes:**

Fiberglass pipe shall conform to ASTM D2996, with short-time rupture strength hoop tensile stress of 30,000 p.s.i. minimum.

The exterior surfaces of the fiberglass floor drains shall be pigmented by the manufacturer with a color that matches the concrete.

The top portion of aluminum floor drains shall be coated to minimize reaction with wet concrete.

The 1/8" aluminum sheet shall be ASTM B 209 alloy 3003-H14 and coated to minimize reaction with wet concrete. Cost included with Concrete Superstructure.

The polyurethane sealant shall be according to Article 1050.04 of the Std. Spec. and the color shall be gray.

MODEL: 0960076-74651-028  
FILE NAME: p:\w\idol-ppw\benley.com\FWIDOT\Documents\DOT Offices\Bureau of Bridges and Structures\Projects\0960076\CADD Plans\0960076-74651

DESIGNED - HAMEED S. SALIH  
CHECKED - PAUL S. JOHNSON  
DRAWN - ANTHONY J. NOVELLO  
CHECKED - HSS / PSJ

EXAMINED  
PASSED  
Mark Shuffler  
ENGINEER OF BRIDGE DESIGN  
Joanne F. ...  
ENGINEER OF BRIDGES AND STRUCTURES

DATE - APRIL 26, 2023  
REVISED -  
REVISED -

STATE OF ILLINOIS  
DEPARTMENT OF TRANSPORTATION

SUPERSTRUCTURE DETAILS  
STRUCTURE NO. 096-0076

SHEET 13 OF 25 SHEETS

F.A.P. RTE.	SECTION	COUNTY	TOTAL SHEETS	SHEET NO.
821	(18BY)B	WAYNE	53	28
CONTRACT NO. 74651				
ILLINOIS		FED. AID PROJECT		

5/8/2023 11:29:31 AM

TOP AND BOTTOM ELEVATIONS  
AT APPROACH FOOTINGS

West Approach			East Approach		
Point/Location	Top	Bottom	Point/Location	Top	Bottom
A - NE	405.03	404.20	A - NW	405.09	404.26
B - E C	405.40	404.57	B - W C	405.46	404.63
C - SE	405.03	404.20	C - SW	405.09	404.26
D - NW	405.00	404.17	D - NE	405.07	404.24
E - W C	405.37	404.54	E - E C	405.44	404.61
F - SW	405.00	404.17	F - SE	405.07	404.24

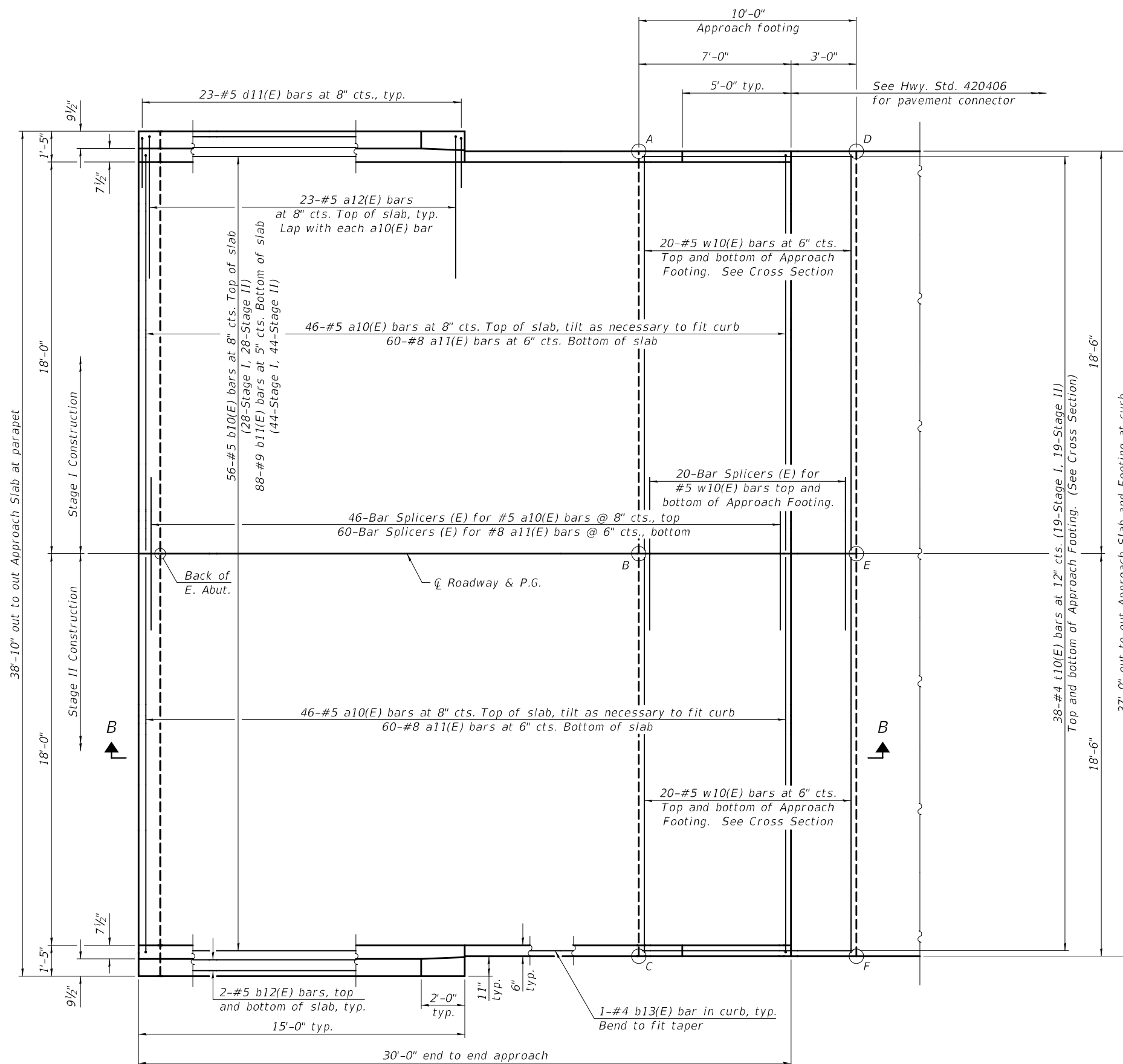

PLAN

(East approach slab shown;  
West approach slab similar by mirror image)

Note:  
See sheet 15 of 25 for Section B-B.

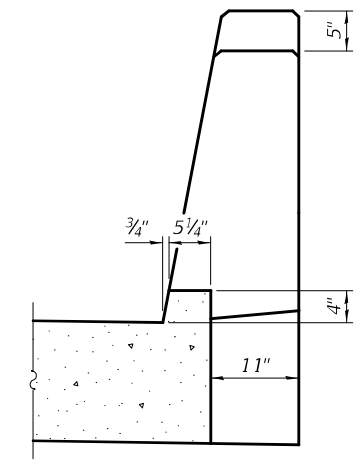
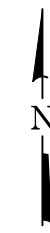

VIEW A-A

(Sheet 1 of 2)

MODEL: 0960076-74651-029  
FILE NAME: p:\w\id\pwb\benley.com\FWIDOT\Documents\IDOT\_Offices\Bureau of Bridges and Structures\Projects\0960076\CADD\_Plans\0960076-74651

DESIGNED -	HAMEED S. SALIH
CHECKED -	PAUL S. JOHNSON
DRAWN -	ANTHONY J. NOVELLO
CHECKED -	HSS / PSJ

EXAMINED	<i>Mark Shuffler</i> ENGINEER OF BRIDGE DESIGN
PASSED	<i>Joey F. [Signature]</i> ENGINEER OF BRIDGES AND STRUCTURES

DATE -	APRIL 26, 2023
REVISED -	
REVISED -	

STATE OF ILLINOIS  
DEPARTMENT OF TRANSPORTATION

BRIDGE APPROACH SLAB DETAILS  
STRUCTURE NO. 096-0076

SHEET 14 OF 25 SHEETS

F.A.P. RTE.	SECTION	COUNTY	TOTAL SHEETS	SHEET NO.
821	(18BY)B	WAYNE	53	29
CONTRACT NO. 74651				

ILLINOIS FED. AID PROJECT

5/8/2023 11:29:56 AM

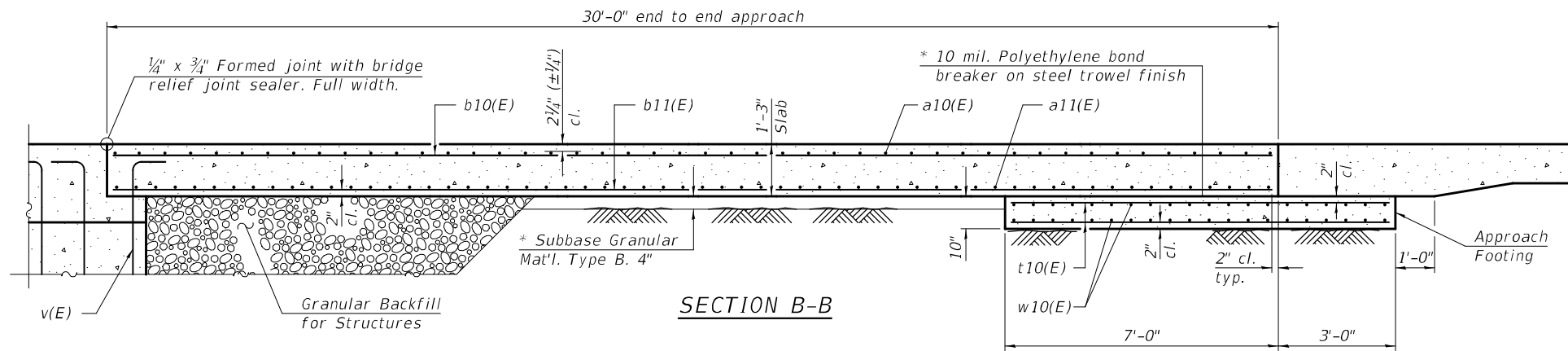

Notes:  
 Parapet concrete shall be paid for as Concrete Superstructure.  
 Approach slab shall be paid for as Concrete Superstructure (Approach Slab).  
 Approach footing concrete shall be paid for as Concrete Structures.  
 The approach footing maximum applied service bearing pressure (Qmax) = 2.0 ksf.  
 Cost of excavation for approach footing included with Concrete Structures.  
 For Granular Backfill for Structures and drainage treatment details, see sheet 2 of 25.  
 See sheet 14 of 25 for View A-A.

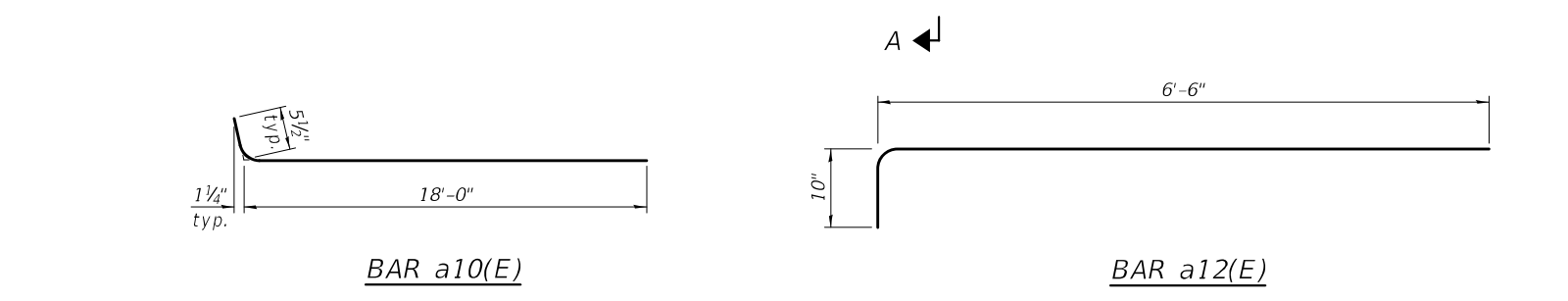
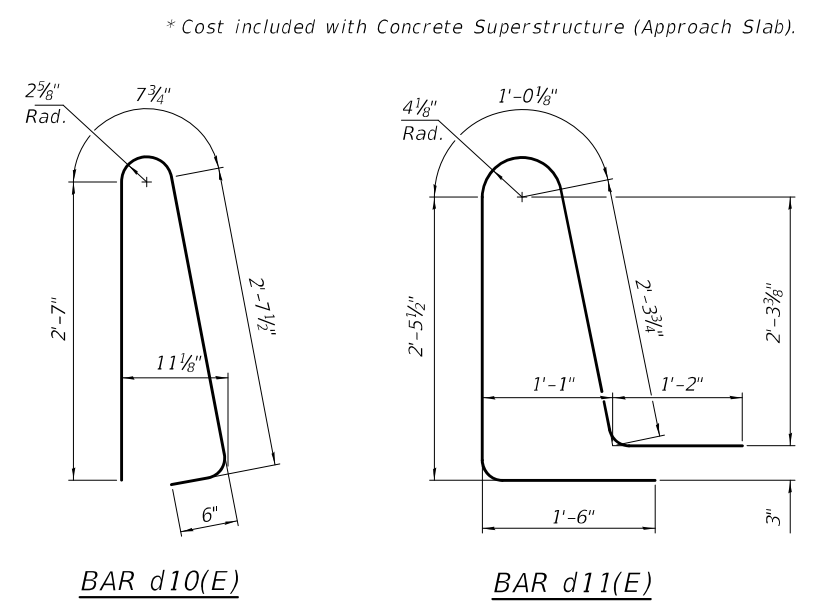
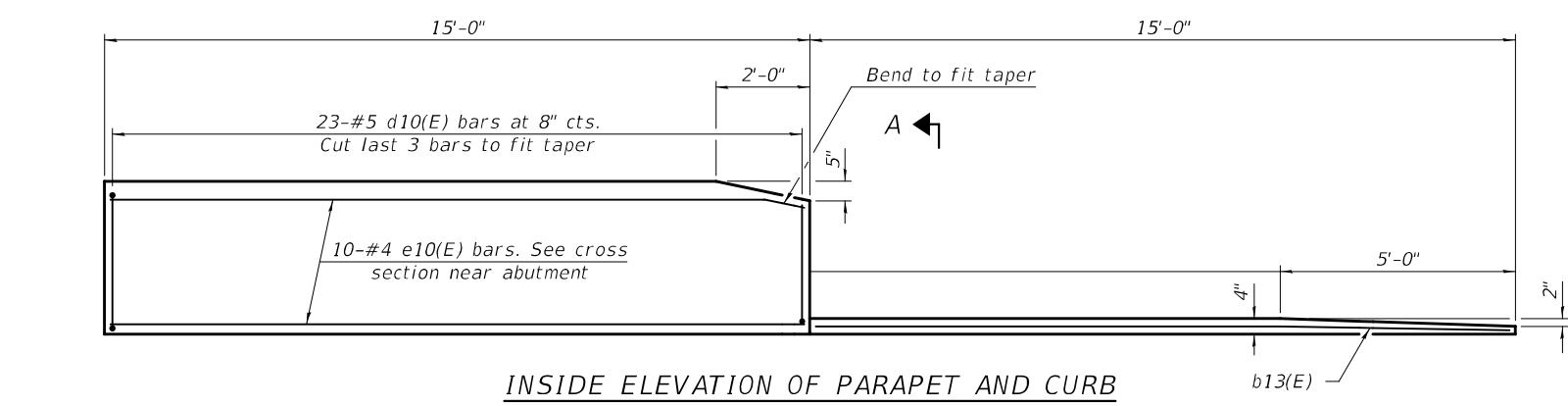
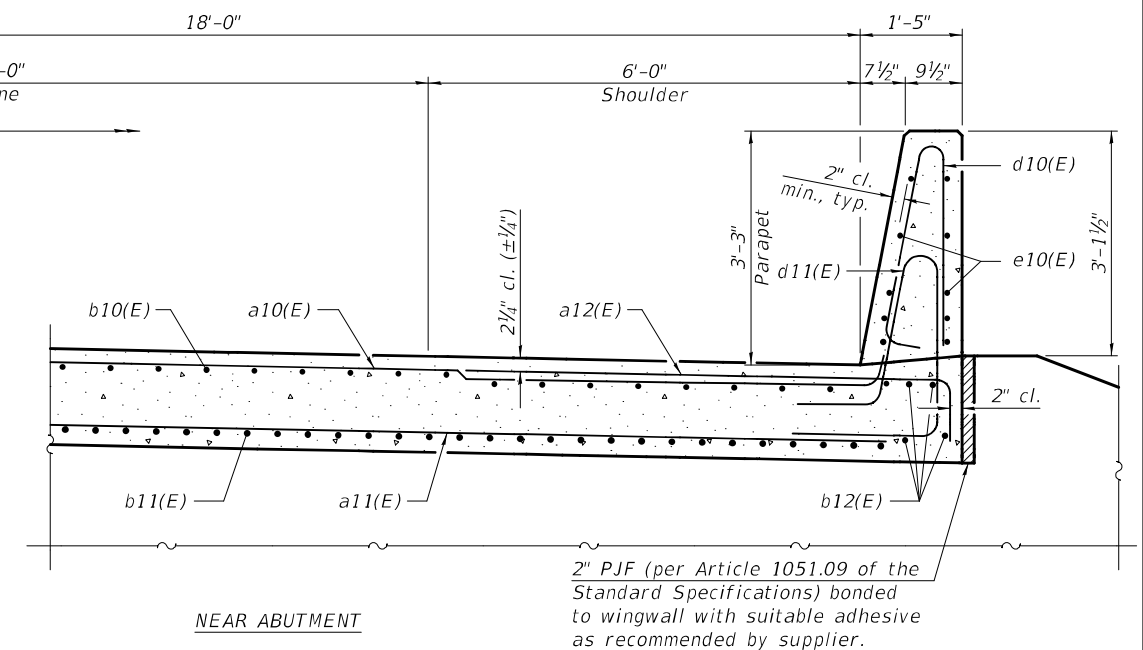
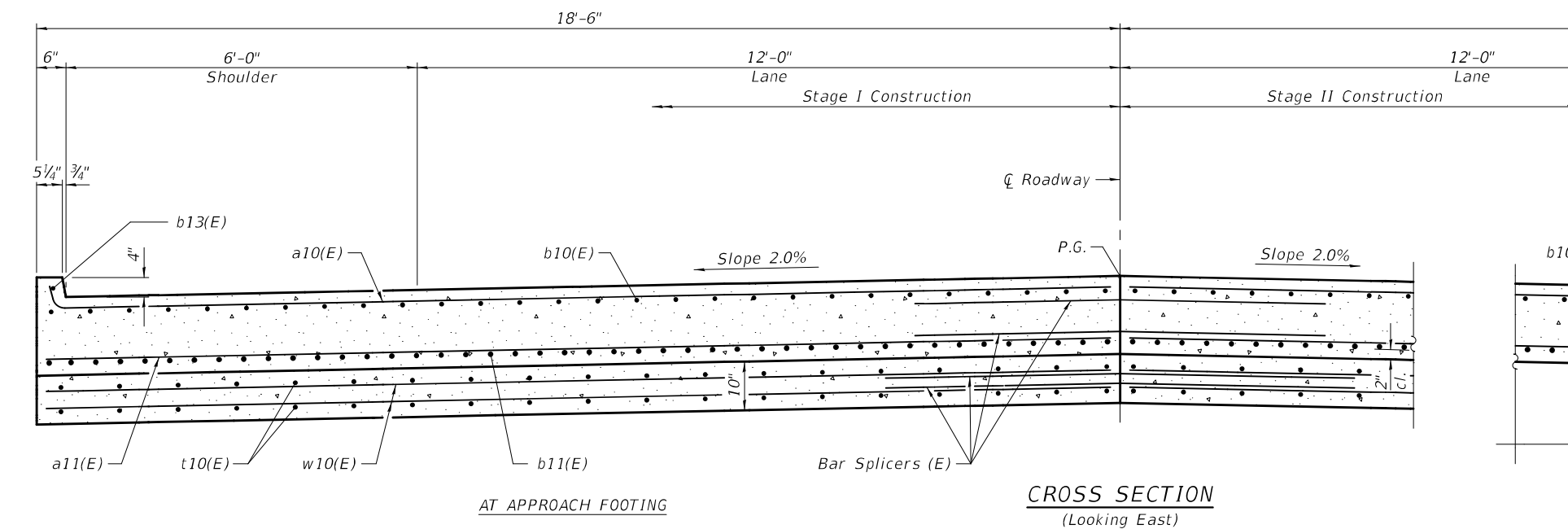

**TWO APPROACHES  
 BILL OF MATERIAL**

Bar	No.	Size	Length	Shape
a10(E)	184	#5	18'-6"	—
a11(E)	240	#8	18'-2"	—
a12(E)	92	#5	7'-4"	—
b10(E)	112	#5	29'-8"	—
b11(E)	176	#9	29'-8"	—
b12(E)	16	#5	14'-8"	—
b13(E)	4	#4	14'-8"	—
d10(E)	92	#5	6'-5"	⤴
d11(E)	92	#5	8'-6"	⤴
e10(E)	40	#4	14'-8"	—
t10(E)	152	#4	9'-8"	—
w10(E)	160	#5	18'-2"	—
Concrete Superstructure			Cu. Yd.	7.7
Concrete Superstructure (Approach Slab)			Cu. Yd.	105.9
Concrete Structures			Cu. Yd.	22.8
Reinforcement Bars, Epoxy Coated			Pound	43,230

(Sheet 2 of 2)

MODEL: 0960076-74651-030  
 FILE NAME: p:\w\idol-ppw-bentley.com\FWIDOT\Documents\Bureau of Bridges and Structures\Projects\0960076\CADD Plans\0960076-74651

DESIGNED - HAMEED S. SALIH	EXAMINED - <i>Mark Shuffler</i>	DATE - APRIL 26, 2023
CHECKED - PAUL S. JOHNSON	PASSED - <i>Joanne F. ...</i>	REVISIONS -
DRAWN - ANTHONY J. NOVELLO		
CHECKED - HSS / PSJ		

STATE OF ILLINOIS  
 DEPARTMENT OF TRANSPORTATION

BRIDGE APPROACH SLAB DETAILS  
 STRUCTURE NO. 096-0076

SHEET 15 OF 25 SHEETS

F.A.P. RTE. 821	SECTION (18BY)B	COUNTY WAYNE	TOTAL SHEETS 53	SHEET NO. 30
CONTRACT NO. 74651				
ILLINOIS FED. AID PROJECT				

5/8/2023 11:30:26 AM

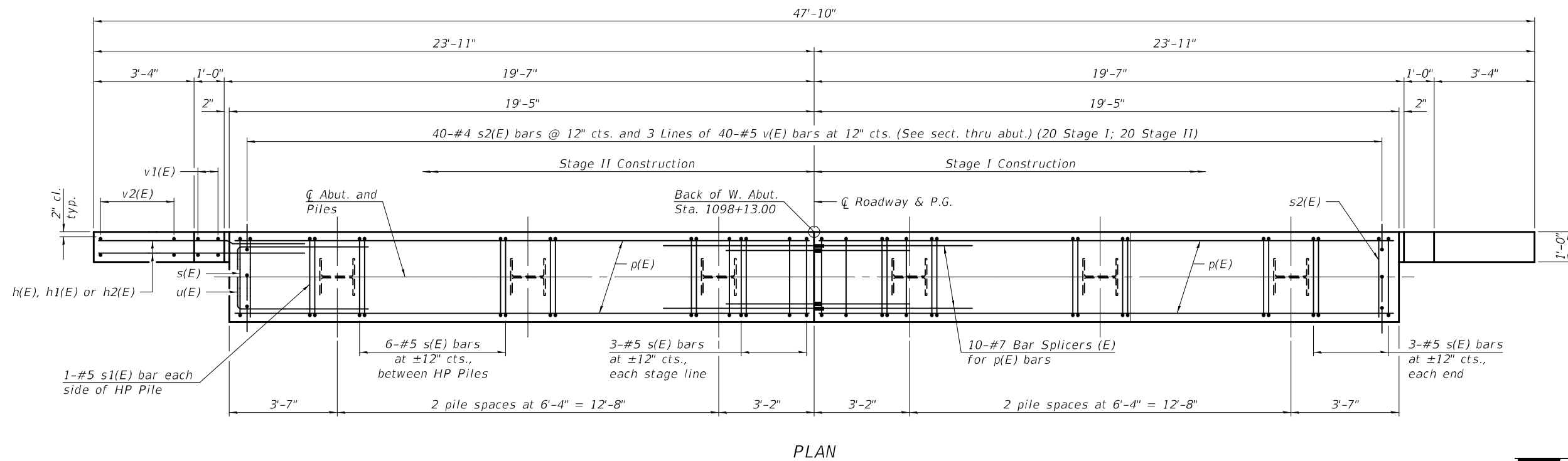
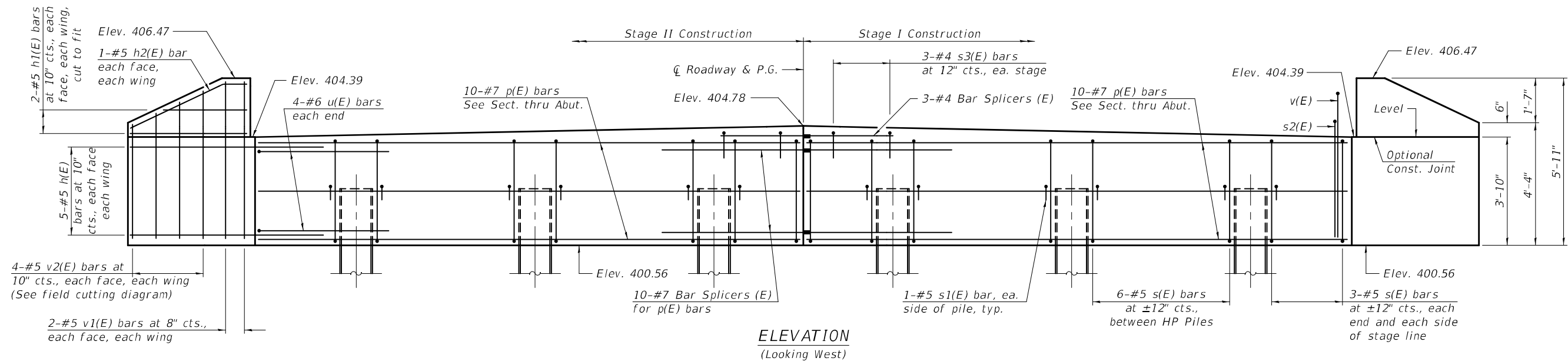

**WEST ABUTMENT PILE DATA**

Type: HP14x89  
 Nominal Required Bearing: 705 kips  
 Factored Resistance Available: 373 kips  
 Est. Length: 58'-0"  
 No. Production Piles: 6  
 No. Test Piles: 0

Note:  
 See sheet 18 of 25 for additional details, notes and Bill of Material.

MODEL: 0960076-74651-031  
 FILE NAME: p:\w\p\benley.com\FWIDOT\Documents\DOT Offices\Bureau of Bridges and Structures\Projects\0960076\CADD Plans\0960076-74651

DESIGNED -	HAMEED S. SALIH
CHECKED -	PAUL S. JOHNSON
DRAWN -	ANTHONY J. NOVELLO
CHECKED -	HSS / PSJ

EXAMINED	<i>Mark Shuffler</i> ENGINEER OF BRIDGE DESIGN
PASSED	<i>Jaime F. ...</i> ENGINEER OF BRIDGES AND STRUCTURES

DATE -	APRIL 26, 2023
REVISED -	---
REVISED -	---

**STATE OF ILLINOIS  
 DEPARTMENT OF TRANSPORTATION**

**WEST ABUTMENT  
 STRUCTURE NO. 096-0076**

SHEET 16 OF 25 SHEETS

F.A.P. RTE.	SECTION	COUNTY	TOTAL SHEETS	SHEET NO.
821	(18BY)B	WAYNE	53	31
CONTRACT NO. 74651				
ILLINOIS FED. AID PROJECT				

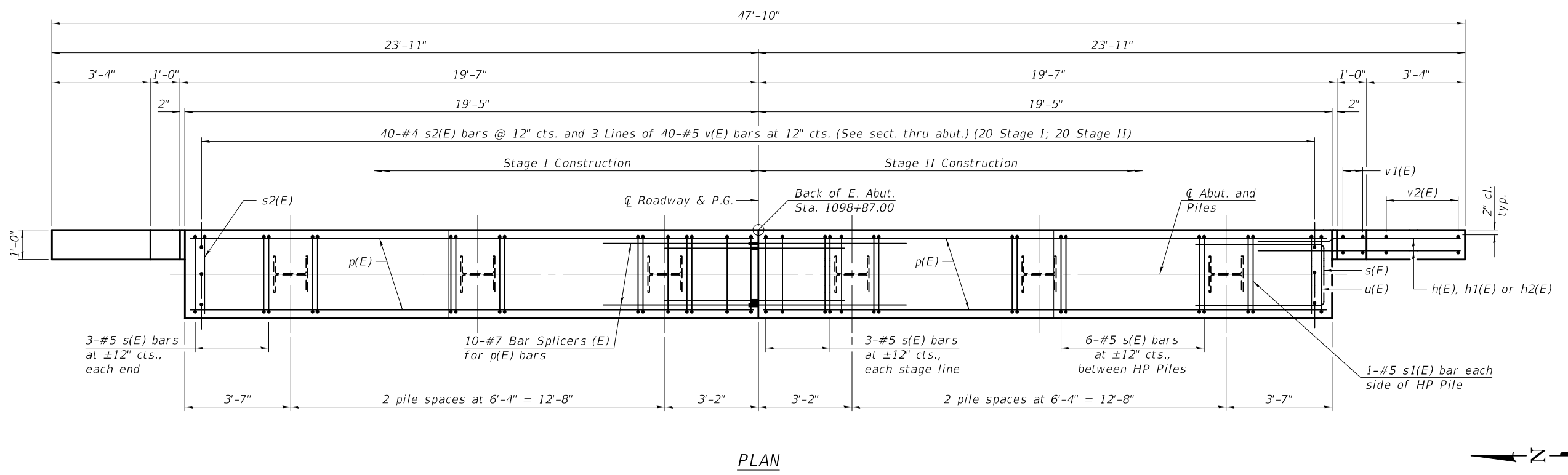
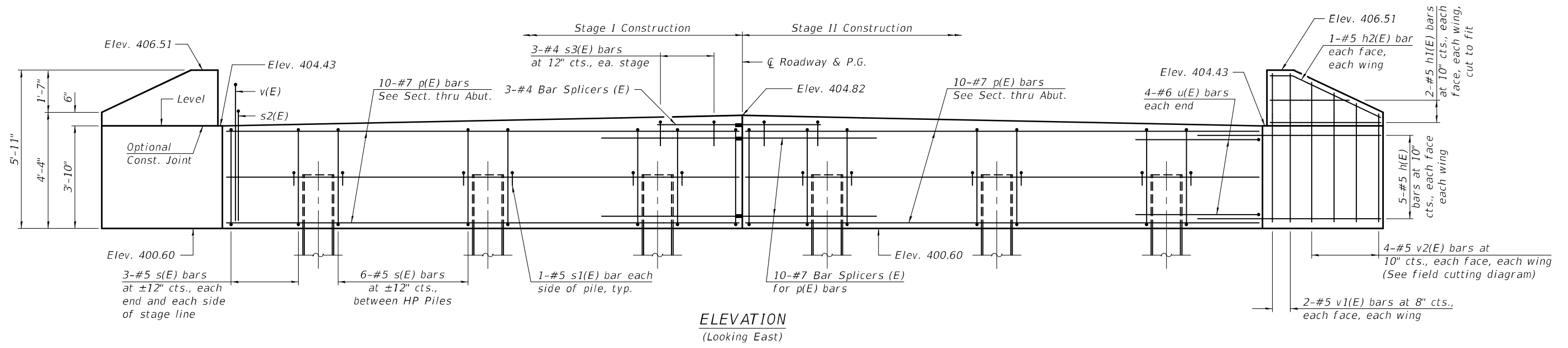

**EAST ABUTMENT PILE DATA**

Type: HP14x89  
 Nominal Required Bearing: 705 kips  
 Factored Resistance Available: 373 kips  
 Est. Length: 58'-0"  
 No. Production Piles: 6  
 No. Test Piles: 0

Note:  
 See sheet 18 of 25 for additional details, notes and Bill of Material.

MODEL: 0960076-74651-032  
 FILE NAME: p:\w\p\w\benley.com\FWIDOT\Documents\DOT Offices\Bureau of Bridges and Structures\Projects\0960076\CADD Plans\0960076-74651

DESIGNED - HAMEED S. SALIH	EXAMINED
CHECKED - PAUL S. JOHNSON	PASSED
DRAWN - ANTHONY J. NOVELLO	
CHECKED - HSS / PSJ	

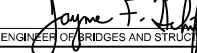
  
 ENGINEER OF BRIDGE DESIGN  
  
 ENGINEER OF BRIDGES AND STRUCTURES

DATE - APRIL 26, 2023
REVISED -
REVISED -

**STATE OF ILLINOIS**  
**DEPARTMENT OF TRANSPORTATION**

**EAST ABUTMENT**  
**STRUCTURE NO. 096-0076**  
 SHEET 17 OF 25 SHEETS

F.A.P. RTE. 821	SECTION (18BY)B	COUNTY WAYNE	TOTAL SHEETS 53	SHEET NO. 32
CONTRACT NO. 74651				
ILLINOIS FED. AID PROJECT				



**WEST ABUTMENT  
BILL OF MATERIAL**

Bar	No.	Size	Length	Shape
h(E)	20	#5	6'-10"	—
h1(E)	8	#5	4'-4"	—
h2(E)	4	#5	4'-4"	—
p(E)	20	#7	19'-1"	—
s(E)	36	#5	13'-3"	□
s1(E)	12	#5	3'-8"	┌
s2(E)	40	#4	6'-9"	└
s3(E)	6	#4	4'-8"	┐
u(E)	8	#6	11'-2"	▭
v(E)	120	#5	5'-11"	┌
v1(E)	8	#5	5'-7"	—
v2(E)	8	#5	9'-4"	—
Structure Excavation			Cu. Yd.	67
Concrete Structures			Cu. Yd.	19.1
Reinforcement Bars, Epoxy Coated			Pound	2,720
Furnishing Steel Piles, HP14x89			Foot	348
Driving Piles			Foot	348

For details of piles, see sheet 21 of 25.

**EAST ABUTMENT  
BILL OF MATERIAL**

Bar	No.	Size	Length	Shape
h(E)	20	#5	6'-10"	—
h1(E)	8	#5	4'-4"	—
h2(E)	4	#5	4'-4"	—
p(E)	20	#7	19'-1"	—
s(E)	36	#5	13'-3"	□
s1(E)	12	#5	3'-8"	┌
s2(E)	40	#4	6'-9"	└
s3(E)	6	#4	4'-8"	┐
u(E)	8	#6	11'-2"	▭
v(E)	120	#5	5'-11"	┌
v1(E)	8	#5	5'-7"	—
v2(E)	8	#5	9'-4"	—
Structure Excavation			Cu. Yd.	67
Concrete Structures			Cu. Yd.	19.1
Reinforcement Bars, Epoxy Coated			Pound	2,720
Furnishing Steel Piles, HP14x89			Foot	348
Driving Piles			Foot	348

For details of piles, see sheet 21 of 25.

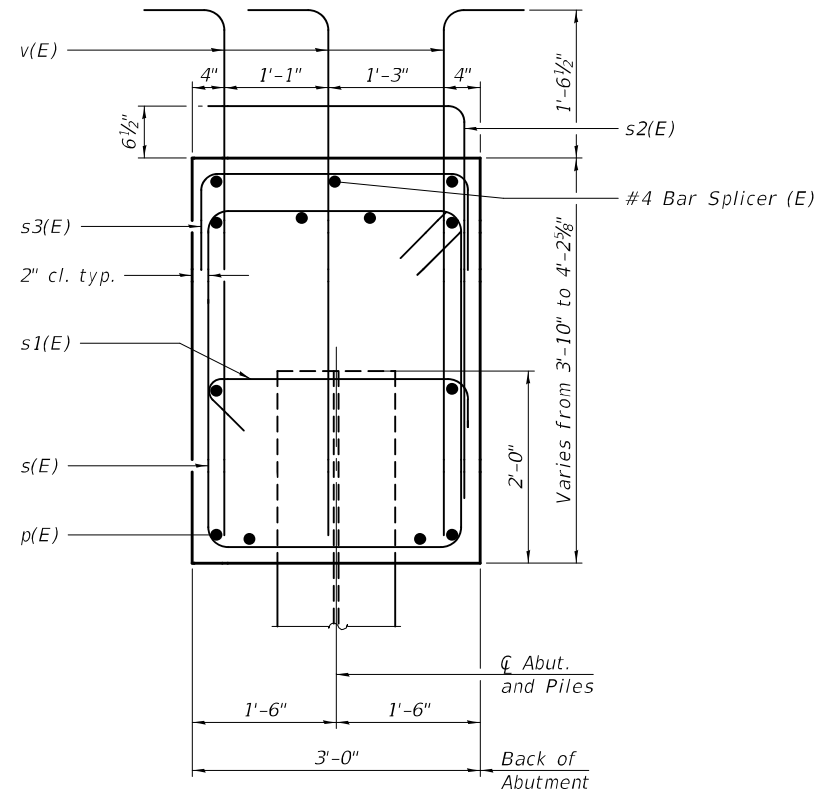

**SECTION THRU  
ABUTMENT**

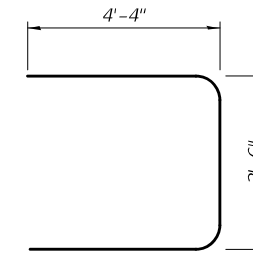

**BAR u(E)**

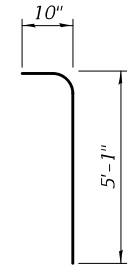

**BAR v(E)**

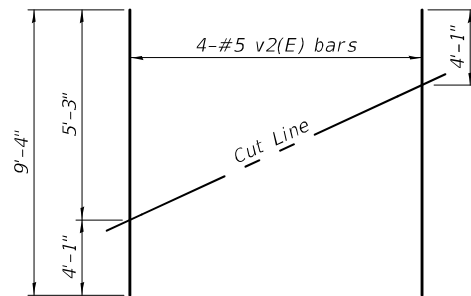

**FIELD CUTTING DIAGRAM**

Order v2(E) full length. Cut as shown and use remainder of bars in opposite wing.

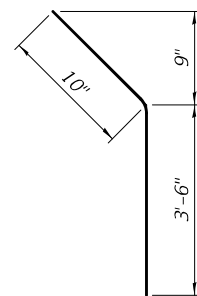

**BAR h2(E)**

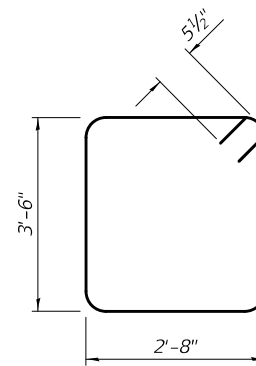

**BAR s(E)**

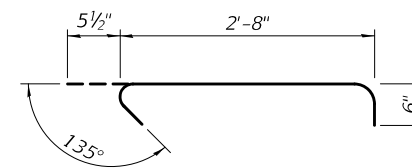

**BAR s1(E)**

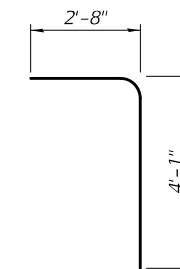

**BAR s2(E)**

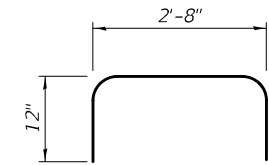

**BAR s3(E)**

MODEL: 0960076-74651-033  
FILE NAME: p:\w\idol-pw\benley.com\FWIDOT\Documents\DOT Offices\Bureau of Bridges and Structures\Projects\0960076\CADD Plans\0960076-74651

DESIGNED -	HAMEED S. SALIH
CHECKED -	PAUL S. JOHNSON
DRAWN -	ANTHONY J. NOVELLO
CHECKED -	HSS / PSJ

EXAMINED	<i>Mark Shuffan</i> ENGINEER OF BRIDGE DESIGN
PASSED	<i>Jaime F. Hoff</i> ENGINEER OF BRIDGES AND STRUCTURES

DATE -	APRIL 26, 2023
REVISED -	—
REVISED -	—

**STATE OF ILLINOIS  
DEPARTMENT OF TRANSPORTATION**

**ABUTMENT DETAILS  
STRUCTURE NO. 096-0076**

SHEET 18 OF 25 SHEETS

F.A.P. RTE.	SECTION	COUNTY	TOTAL SHEETS	SHEET NO.
821	(18BY)B	WAYNE	53	33
CONTRACT NO. 74651				
ILLINOIS FED. AID PROJECT				

5/8/2023 11:31:44 AM

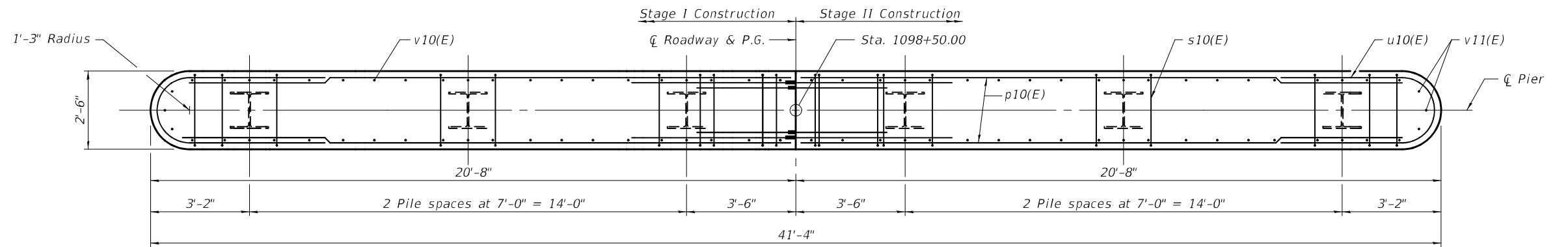

PLAN

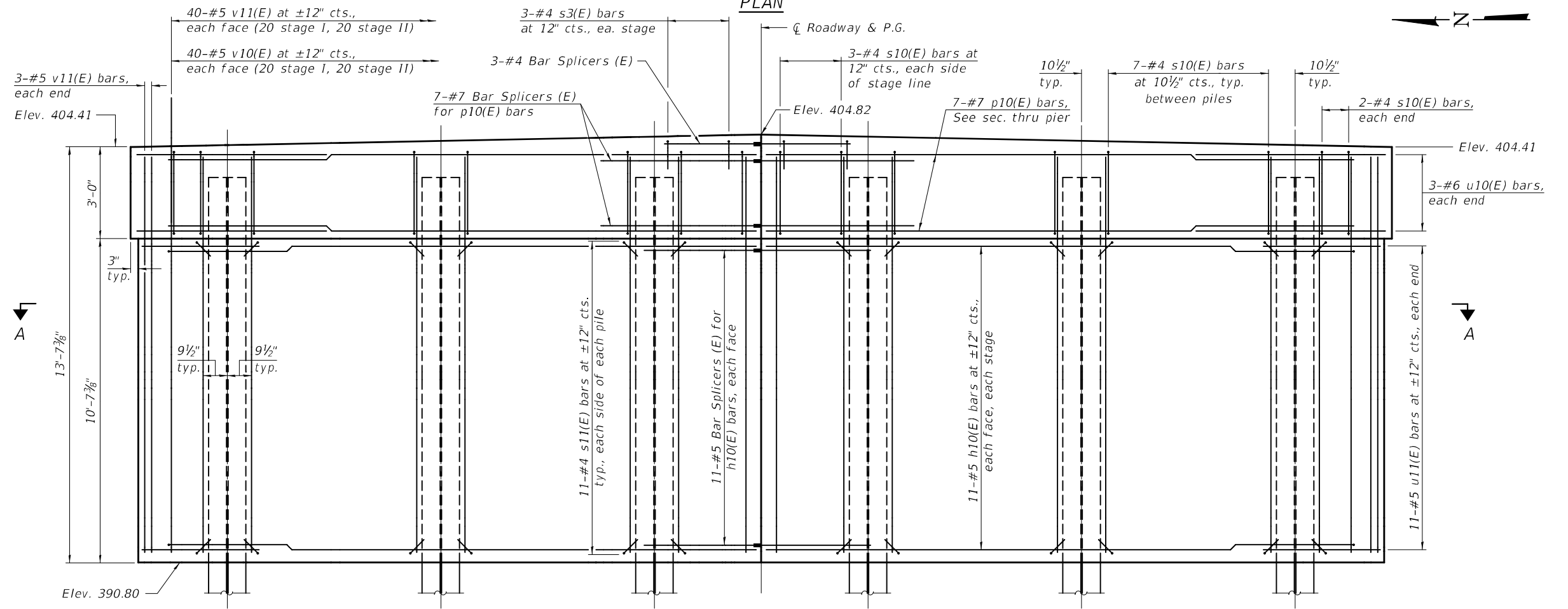

ELEVATION  
(Looking East)

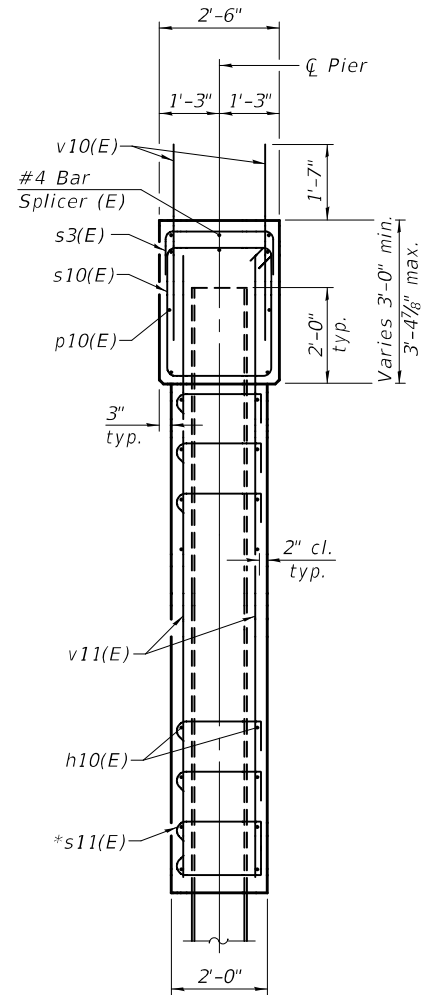

SECTION THRU PIER

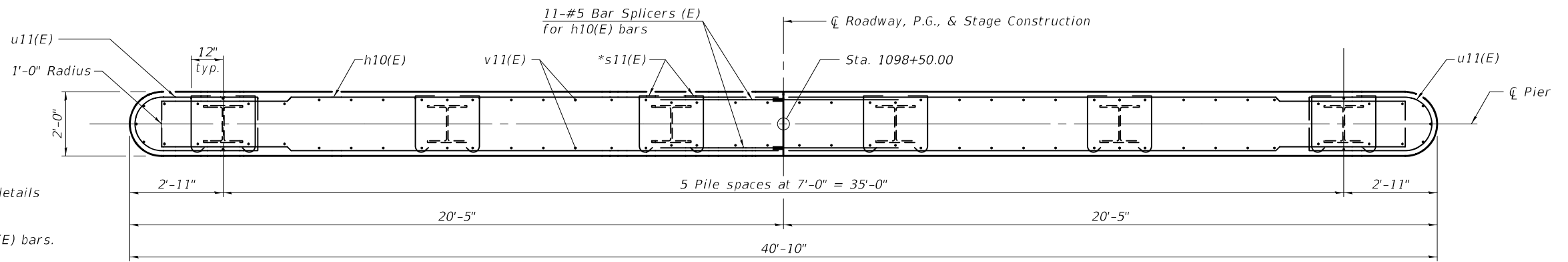

SECTION A-A

Notes:  
 See sheet 20 of 25 for additional pier details and Bill of Material.  
 See sheet 21 of 25 for details of piles.  
 \*Hook s11(E) bar around h10(E) and v11(E) bars.  
 Clear cover for s11(E) bar will be 1 1/2".

MODEL: 0960076-74651-034  
 FILE NAME: p:\w\idol-pw-bentley.com\FWIDOT\Documents\Bureau of Bridges and Structures\Projects\0960076\CADD Plans\0960076-74651

DESIGNED - HAMEED S. SALIH	EXAMINED
CHECKED - PAUL S. JOHNSON	PASSED
DRAWN - ANTHONY J. NOVELLO	
CHECKED - HSS / PSJ	

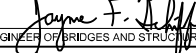
  
 MARK SHUFFLER  
 ENGINEER OF BRIDGE DESIGN  
  
 JAYME F. [unclear]  
 ENGINEER OF BRIDGES AND STRUCTURES

DATE - APRIL 26, 2023
REVISED -
REVISED -

STATE OF ILLINOIS  
 DEPARTMENT OF TRANSPORTATION

**PIER**  
**STRUCTURE NO. 096-0076**  
 SHEET 19 OF 25 SHEETS

F.A.P. RTE. 821	SECTION (18BY)B	COUNTY WAYNE	TOTAL SHEETS 53	SHEET NO. 34
CONTRACT NO. 74651				
ILLINOIS FED. AID PROJECT				

**PIER  
BILL OF MATERIAL**

Bar	No.	Size	Length	Shape
h10(E)	44	#5	20'-1"	
p10(E)	14	#7	19'-3"	
s3(E)	6	#4	4'-8"	
s10(E)	38	#4	10'-5"	
s11(E)	132	#4	2'-10"	
u10(E)	6	#6	12'-0"	
u11(E)	22	#5	10'-3"	
v10(E)	80	#5	4'-1"	
v11(E)	86	#5	13'-3"	
Cofferdam Excavation		Cu. Yd.	96	
Cofferdam (Type 1) (Location 1)		Each	1	
Concrete Structures		Cu. Yd.	43.9	
Reinforcement Bars, Epoxy Coated		Pound	3,880	
Furnishing Steel Piles HP14X89		Foot	348	
Driving Piles		Foot	348	

For s3(E) bar detail, see Sheet 18 of 25.

**PILE DATA**

Type: HP14x89  
 Nominal Required Bearing: 705 kips  
 Factored Resistance Available: 373 kips  
 Est. Length: 58'-0"  
 No. Production Piles: 6  
 No. Test Piles: 0

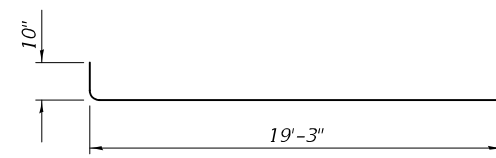

**Bar h10(E)**

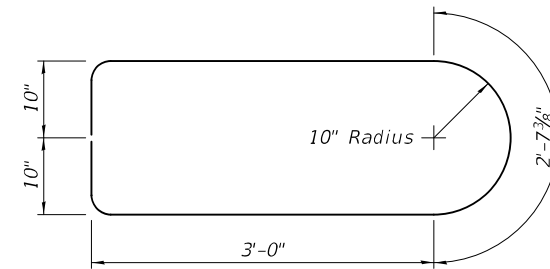

**Bar u11(E)**

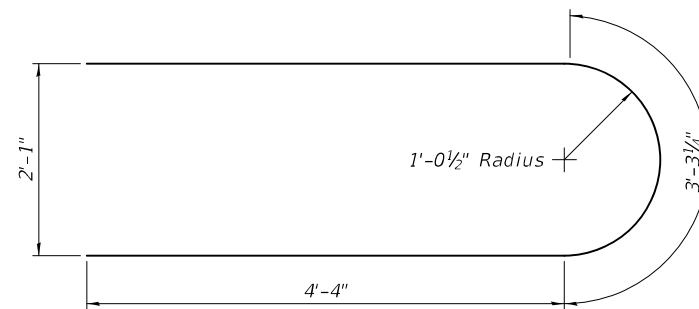

**Bar u10(E)**

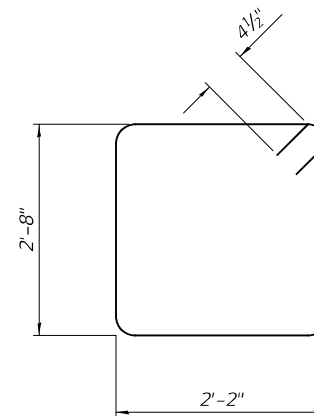

**Bar s10(E)**

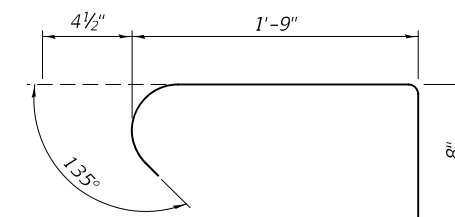

**Bar s11(E)**

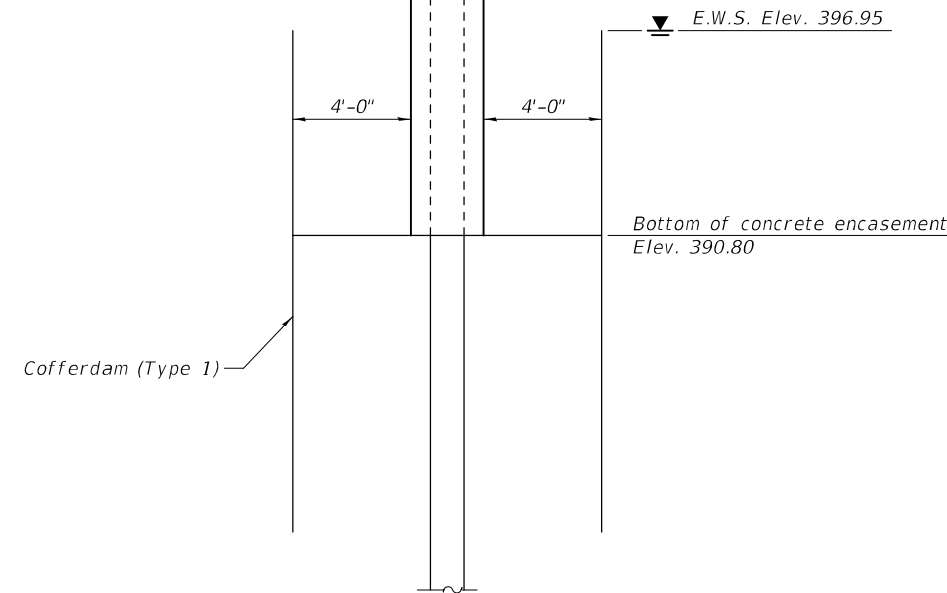

**COFFERDAM DETAIL**

Notes:  
 For details of piles, see sheet 21 of 25.

MODEL: 0960076-74651-035  
 FILE NAME: p:\w\p\w\benley.com\FWIDOT\Documents\DOT Offices\Bureau of Bridges and Structures\Projects\0960076\CADD Plans\0960076-74651

DESIGNED - HAMEED S. SALIH	EXAMINED
CHECKED - PAUL S. JOHNSON	PASSED
DRAWN - ANTHONY J. NOVELLO	
CHECKED - HSS / PSJ	

DATE - APRIL 26, 2023  
 Mark Shaffer  
 ENGINEER OF BRIDGE DESIGN  
 Jayne F. [Signature]  
 ENGINEER OF BRIDGES AND STRUCTURES

REVISIONS	DATE
REVISIONS	DATE
REVISIONS	DATE

**STATE OF ILLINOIS  
DEPARTMENT OF TRANSPORTATION**

**PIER DETAILS  
STRUCTURE NO. 096-0076**

SHEET 20 OF 25 SHEETS

F.A.P. RTE.	SECTION	COUNTY	TOTAL SHEETS	SHEET NO.
821	(18BY)B	WAYNE	53	35
CONTRACT NO. 74651				
		ILLINOIS	FED. AID PROJECT	

5/8/2023 11:32:37 AM

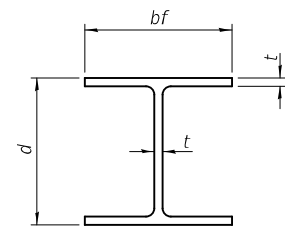

**STEEL PILE TABLE**

Designation	Depth d	Flange width bf	Web and Flange thickness t	Encasement diameter A
HP 14x117	14 1/4"	14 7/8"	1 3/16"	30"
x102	14"	14 3/4"	1 1/16"	30"
x89	13 3/8"	14 3/4"	5/8"	30"
x73	13 3/8"	14 3/8"	1/2"	30"
HP 12x84	12 1/4"	12 1/4"	1 1/16"	24"
x74	12 1/8"	12 1/4"	5/8"	24"
x63	12"	12 1/8"	1/2"	24"
x53	11 3/4"	12"	7/16"	24"
HP 10x57	10"	10 1/4"	9/16"	24"
x42	9 3/4"	10 1/8"	7/16"	24"
HP 8x36	8"	8 1/8"	7/16"	18"

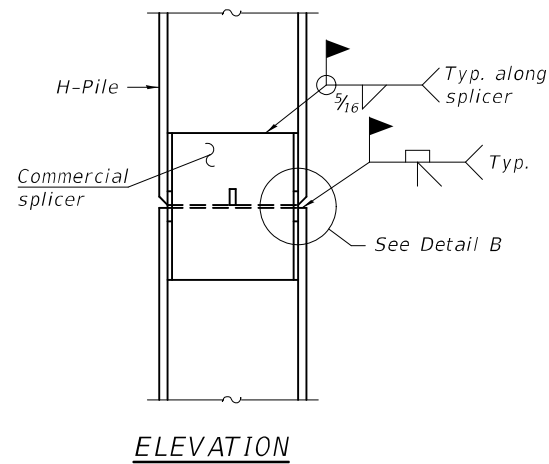

**ELEVATION**

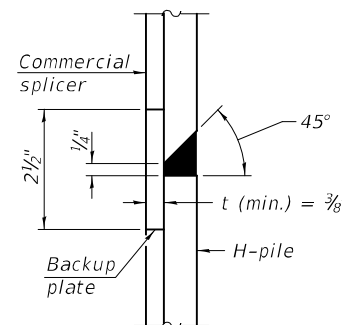

**DETAIL "B"**

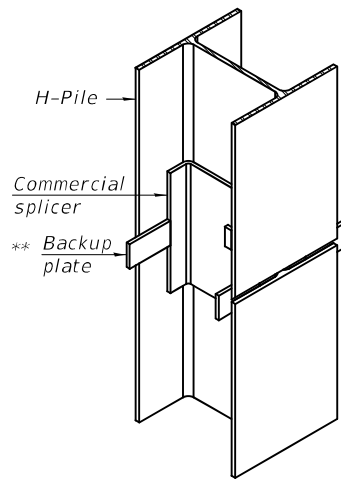

**ISOMETRIC VIEW**

**WELDED COMMERCIAL SPLICE**

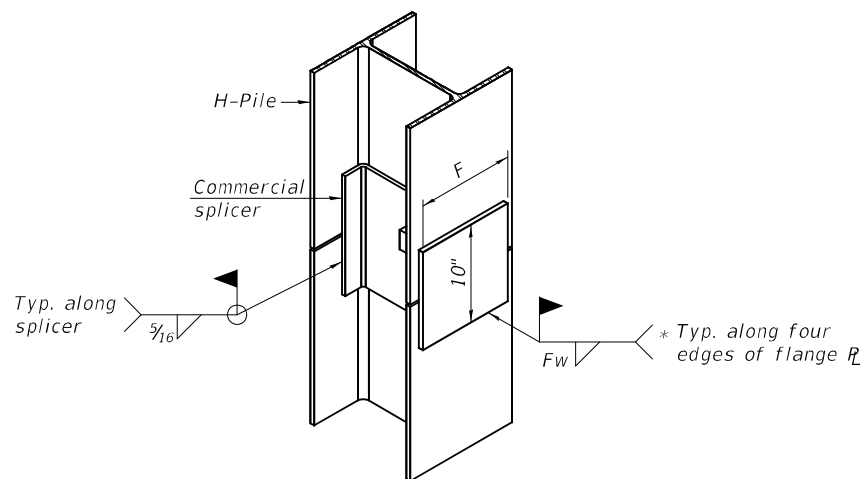

**ISOMETRIC VIEW**

**WELDED COMMERCIAL SPLICE ALTERNATE**

- \* Interrupt welds 1/4" from end of web and/or each flange.
- \*\* Remove portions of backup plates that extend outside the flanges.
- \*\*\* Weld size per pile shoe manufacturer (5/16" min.).

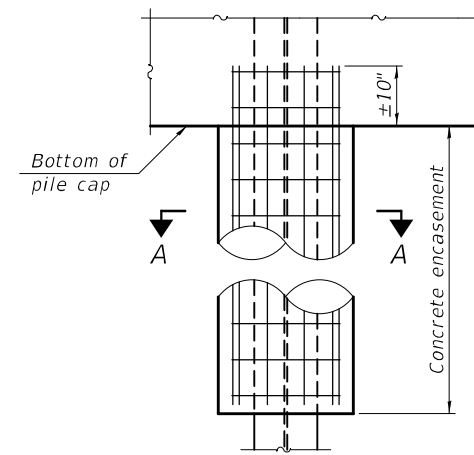

**ELEVATION**

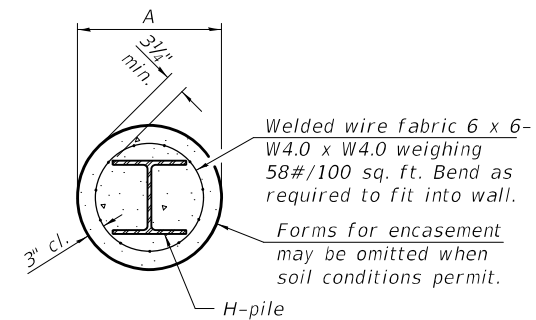

**SECTION A-A**

**INDIVIDUAL PILE CONCRETE ENCASUREMENT**  
(when specified)

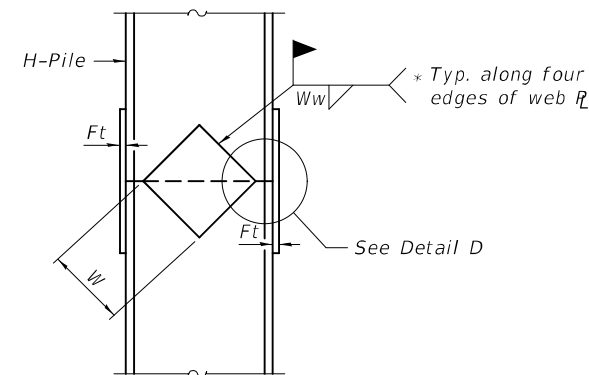

**ELEVATION**

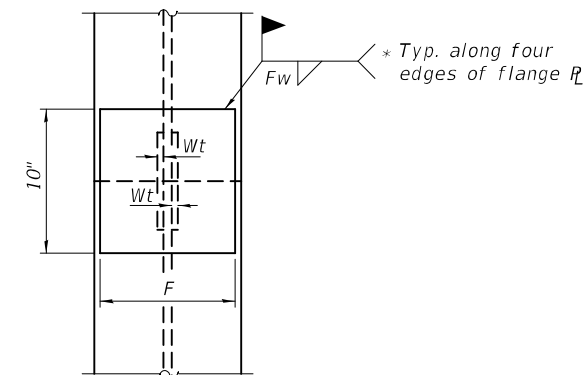

**END VIEW**

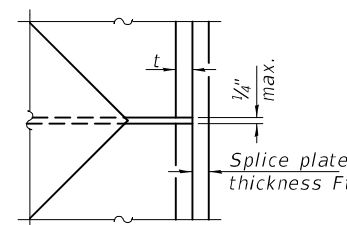

**DETAIL D**

**WELDED PLATE FIELD SPLICE**

Designation	F	Ft	Fw	W	Wt	Ww
HP 14x117	12 1/2"	1"	7/8"	7 3/4"	5/8"	1/2"
x102	12 1/2"	7/8"	3/4"	7 3/4"	5/8"	1/2"
x89	12 1/2"	3/4"	1 1/16"	7 3/4"	5/8"	1/2"
x73	12 1/2"	5/8"	9/16"	7 3/4"	5/8"	1/2"
HP 12x84	10"	7/8"	1 1/16"	6 1/2"	5/8"	1/2"
x74	10"	7/8"	1 1/16"	6 1/2"	5/8"	1/2"
x63	10"	5/8"	1/2"	6 1/2"	1/2"	3/8"
x53	10"	5/8"	1/2"	6 1/2"	1/2"	3/8"
HP 10x57	8"	3/4"	9/16"	5 1/4"	1/2"	3/8"
x42	8"	5/8"	9/16"	5 1/4"	1/2"	3/8"
HP 8x36	7"	5/8"	7/16"	4 1/4"	1/2"	3/8"

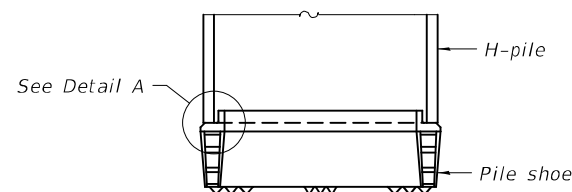

**ELEVATION**

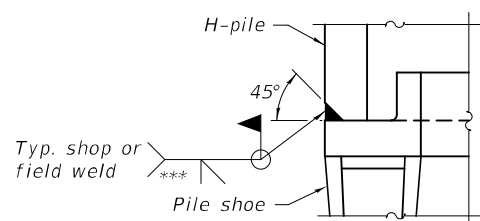

**DETAIL A**

**SHOE ATTACHMENT**

Note:  
The steel H-piles shall be according to AASHTO M270 Grade 50.

F-HP 2-1-2023

DESIGNED - HAMEED S. SALIH	EXAMINED
CHECKED - PAUL S. JOHNSON	PASSED
DRAWN - ANTHONY J. NOVELLO	
CHECKED - HSS / PSJ	

DATE - APRIL 26, 2023	STATE OF ILLINOIS DEPARTMENT OF TRANSPORTATION
REVISIONS	

DATE - APRIL 26, 2023	STATE OF ILLINOIS DEPARTMENT OF TRANSPORTATION
REVISIONS	

STATE OF ILLINOIS  
DEPARTMENT OF TRANSPORTATION

HP PILE DETAILS  
STRUCTURE NO. 096-0076

SHEET 21 OF 25 SHEETS

F.A.P. RTE. 821	SECTION (18BY)B	COUNTY WAYNE	TOTAL SHEETS 53	SHEET NO. 36
CONTRACT NO. 74651			ILLINOIS FED. AID PROJECT	

MODEL: 0960076-74651-036  
FILE NAME: p:\w\p\w\benley.com\FWIDOT\Documents\DOT Offices\Bureau of Bridges and Structures\Projects\0960076\CADD Plans\0960076-74651

5/8/2023 11:33:15 AM

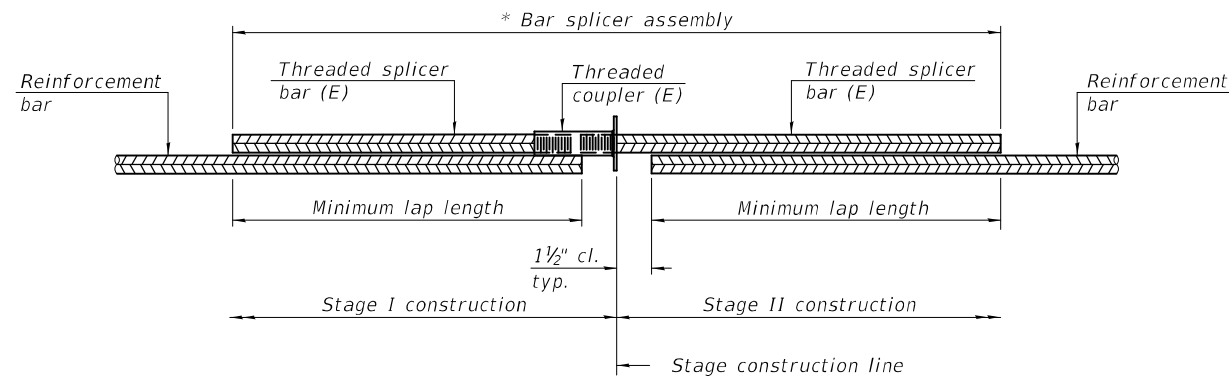

**STANDARD BAR SPLICER ASSEMBLY PLAN**

Only bar splicer assemblies as presented on the approved QPL list may be used.

Threaded splicer bar length = min. lap length + 1 1/2" + thread length

\* Epoxy not required on Bar Splicer Assembly components used in conjunction with black bars.

Location	Bar size	No. assemblies required	Minimum lap length
Bottom of Slab	#4	6	2'-5"
Bottom of Slab	#5	3	3'-0"
Bottom of Slab	#7	96	4'-2"
Top of Slab	#6	87	4'-0"
Approach Slabs	#5	92	3'-4"
Approach Slabs	#8	120	4'-9"
Approach Slab Footings	#5	80	3'-2"
Abutment Caps	#7	20	5'-0"
Abutment Steps	#4	6	2'-11"
Pier Encasement	#5	22	3'-7"
Pier Cap	#7	7	5'-0"
Pier Step	#4	3	2'-11"

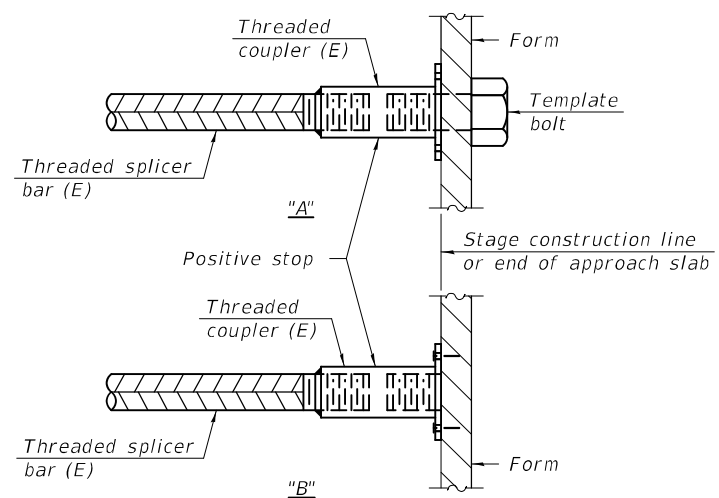

**INSTALLATION AND SETTING METHODS**

"A" : Set bar splicer assembly by means of a template bolt.

"B" : Set bar splicer assembly by nailing to wood forms or cementing to steel forms.

(E) : Indicates epoxy coating.

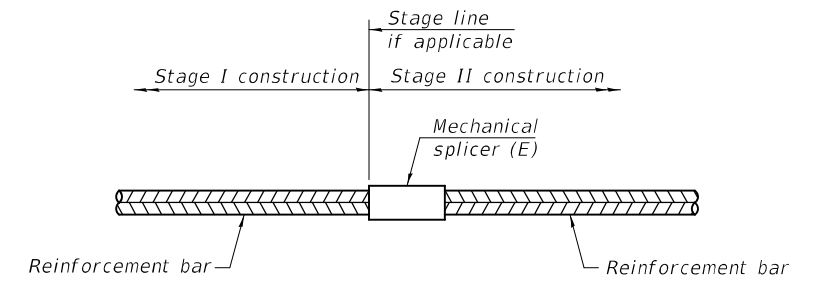

**STANDARD MECHANICAL SPLICER**

Location	Bar size	No. assemblies required

**Notes:**

Splicer bars shall be deformed with threaded ends and have a minimum 60 ksi yield strength.

All reinforcement shall be lapped and tied to the splicer bars.

Bar splicer assemblies shall be epoxy coated according to the requirements for reinforcement bars. See Section 508 of the Standard Specifications.

See approved list of bar splicer assemblies and mechanical splicers for alternatives.

MODEL: 0960076-74651-037  
FILE NAME: p:\w\p\w\benley.com\FW\DOT\Documents\DOT Offices\Bureau of Bridges and Structures\Projects\0960076\CADD Plans\0960076-74651

BSD-1

2-1-2023

DESIGNED - HAMEED S. SALIH	EXAMINED
CHECKED - PAUL S. JOHNSON	PASSED
DRAWN - ANTHONY J. NOVELLO	
CHECKED - HSS / PSJ	

DATE - APRIL 26, 2023

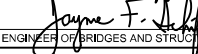
  
 ENGINEER OF BRIDGE DESIGN  
  
 ENGINEER OF BRIDGES AND STRUCTURES

REVISIONS	DATE
REVISIONS -	DATE -
REVISIONS -	DATE -

STATE OF ILLINOIS  
DEPARTMENT OF TRANSPORTATION

BAR SPLICER ASSEMBLY AND MECHANICAL SPLICER DETAILS  
STRUCTURE NO. 096-0076

SHEET 22 OF 25 SHEETS

F.A.P. RTE. 821	SECTION (18BY)B	COUNTY WAYNE	TOTAL SHEETS 53	SHEET NO. 37
ILLINOIS FED. AID PROJECT			CONTRACT NO. 74651	

5/8/2023 11:33:42 AM

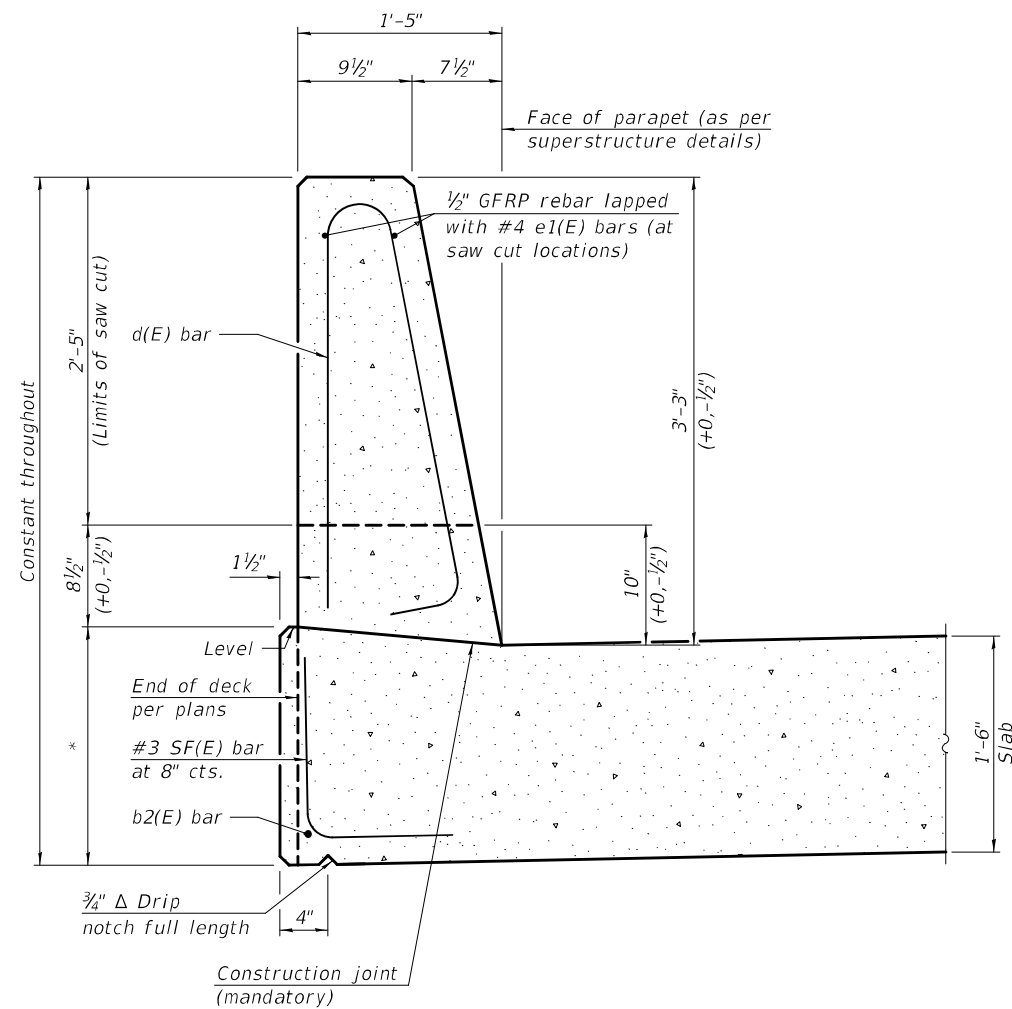

**39" CONSTANT-SLOPE  
PARAPET SECTION**

(Showing dimensions, d(E), and 1/2" Ø GFRP rebar)

\*See Superstructure Details.

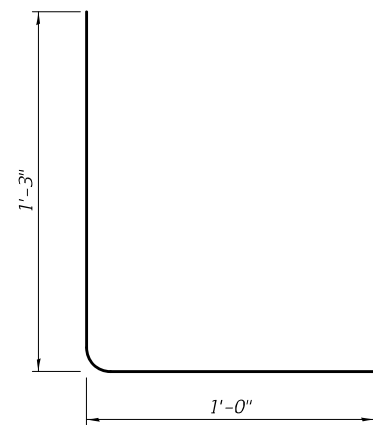

**SF(E) BAR**

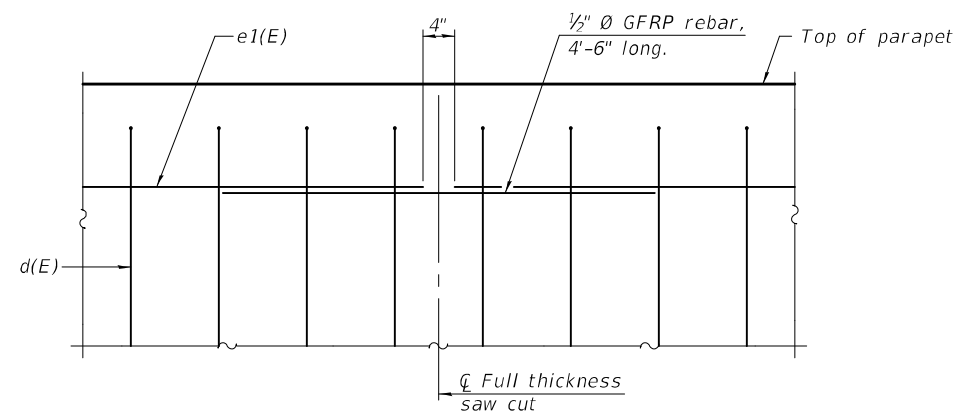

**GFRP REBAR STIFFENING DETAIL**

(Place as shown in parapet section at each parapet joint location.)

Notes:  
 All dimensions shall remain the same as shown on superstructure details, except the deck width increases by 1 1/2" as shown in the Parapet Section. Additional concrete needed to revise the deck width = 0.00750 cu. yds./ft. of 39" parapet each side of the deck.  
 Place full depth aluminum sheets as shown on superstructure details.  
 Replace all cork joint filler locations with a full thickness saw cut.

MODEL: 0960076-74651-038  
 FILE NAME: p:\w\lido-ppw-bentley.com\FWIDOT\Documents\DOT Offices\Bureau of Bridges and Structures\Projects\0960076\CADD Plans\0960076-74651

DESIGNED -	HAMEED S. SALIH
CHECKED -	PAUL S. JOHNSON
DRAWN -	ANTHONY J. NOVELLO
CHECKED -	HSS / PSJ

EXAMINED	<i>Mark Shuffler</i> ENGINEER OF BRIDGE DESIGN	DATE -	APRIL 26, 2023
PASSED	<i>Jaime F. [Signature]</i> ENGINEER OF BRIDGES AND STRUCTURES	REVISED -	---
		REVISED -	---

STATE OF ILLINOIS  
 DEPARTMENT OF TRANSPORTATION

CONCRETE PARAPET SLIPFORMING OPTION  
 STRUCTURE NO. 096-0076

F.A.P. RTE.	SECTION	COUNTY	TOTAL SHEETS	SHEET NO.
821	(18BY)B	WAYNE	53	38
CONTRACT NO. 74651				

SHEET 23 OF 25 SHEETS

ILLINOIS FED. AID PROJECT

5/8/2023 11:34:15 AM





Illinois Department of Transportation  
Division of Highways  
IDOT - D-7

### SOIL BORING LOG

Page 1 of 3  
Date 5/12/20

ROUTE FAP 821 DESCRIPTION Miller Creek - 1 mile West of Sims LOGGED BYE, Sandschafer

SECTION (18BY)B LOCATION NW 1/4, SEC. 9, TWP. 2S, RNG. 6E, 3rd PM, Latitude N 38.371969, Longitude W 88.549339

COUNTY Wayne DRILLING METHOD Hollow stem auger & split spoon HAMMER Auto 140#

STRUCT. NO.	BORING NO.	STATION	DEPTH	DRILLING METHOD				SPT				Description	Depth (ft)	SPT	UCS	MOISTURE	
				D	B	U	M	D	B	U	M						
096-0005 (Existing) 096-0076 (Proposed)	2 East Abutment	1098+42 (E) 1098+53 (P)															

The Unconfined Compressive Strength (UCS) Failure Mode is indicated by (B-Bulge, S-Shear, P-Penetrometer, E-Estimated)  
The SPT (N value) is the sum of the last two blow values in each sampling zone (AASHTO T206), WH-Weight of Hammer, NT-Not Tested.  
BBS, form 137 (Rev. 8-99)



Illinois Department of Transportation  
Division of Highways  
IDOT - D-7

### SOIL BORING LOG

Page 2 of 3  
Date 5/12/20

ROUTE FAP 821 DESCRIPTION Miller Creek - 1 mile West of Sims LOGGED BYE, Sandschafer

SECTION (18BY)B LOCATION NW 1/4, SEC. 9, TWP. 2S, RNG. 6E, 3rd PM, Latitude N 38.371969, Longitude W 88.549339

COUNTY Wayne DRILLING METHOD Hollow stem auger & split spoon HAMMER Auto 140#

STRUCT. NO.	BORING NO.	STATION	DEPTH	DRILLING METHOD				SPT				Description	Depth (ft)	SPT	UCS	MOISTURE	
				D	B	U	M	D	B	U	M						
096-0005 (Existing) 096-0076 (Proposed)	2 East Abutment	1098+42 (E) 1098+53 (P)															

The Unconfined Compressive Strength (UCS) Failure Mode is indicated by (B-Bulge, S-Shear, P-Penetrometer, E-Estimated)  
The SPT (N value) is the sum of the last two blow values in each sampling zone (AASHTO T206), WH-Weight of Hammer, NT-Not Tested.  
BBS, form 137 (Rev. 8-99)



Illinois Department of Transportation  
Division of Highways  
IDOT - D-7

### ROCK CORE LOG

Page 3 of 3  
Date 5/12/20

ROUTE FAP 821 DESCRIPTION Miller Creek - 1 mile West of Sims LOGGED BYE, Sandschafer

SECTION (18BY)B LOCATION NW 1/4, SEC. 9, TWP. 2S, RNG. 6E, 3rd PM, Latitude N 38.371969, Longitude W 88.549339

COUNTY Wayne CORING METHOD Rotary, surf set diamond bit

STRUCT. NO.	BORING NO.	STATION	DEPTH	CORING METHOD	CORING BARREL TYPE & SIZE	CORE DIAMETER	TOP OF ROCK ELEV.	BEGIN CORE ELEV.	RECOVERY									
									RECOVERY	RECOVERY	RECOVERY	RECOVERY						
096-0005 (Existing) 096-0076 (Proposed)	2 East Abutment	1098+42 (E) 1098+53 (P)																

Color pictures of the cores Available on request  
Cores will be stored for examination until 5/12/2025  
The "Strength" column represents the uniaxial compressive strength of the core sample (ASTM D-2938)  
BBS, form 138 (Rev. 8-99)

MODEL: 0960076-74651-040 FILE NAME: p:\w\p\w\benley.com\FWIDOT Documents\IDOT Offices\Bureau of Bridges and Structures\Projects\0960076\CADD Plans\0960076-74651

DESIGNED - HAMEED S. SALIH	EXAMINED	DATE - APRIL 26, 2023
CHECKED - PAUL S. JOHNSON	PASSED	REVISED -
DRAWN - ANTHONY J. NOVELLO		REVISED -
CHECKED - HSS / PSJ		

Mark Shuffler  
ENGINEER OF BRIDGE DESIGN  
Jayne F. Saffell  
ENGINEER OF BRIDGES AND STRUCTURES

STATE OF ILLINOIS  
DEPARTMENT OF TRANSPORTATION

SOIL BORING LOGS  
STRUCTURE NO. 096-0076

SHEET 25 OF 25 SHEETS

F.A.P. RTE.	SECTION	COUNTY	TOTAL SHEETS	SHEET NO.
821	(18BY)B	WAYNE	53	40
CONTRACT NO. 74651				
		ILLINOIS	FED. AID PROJECT	



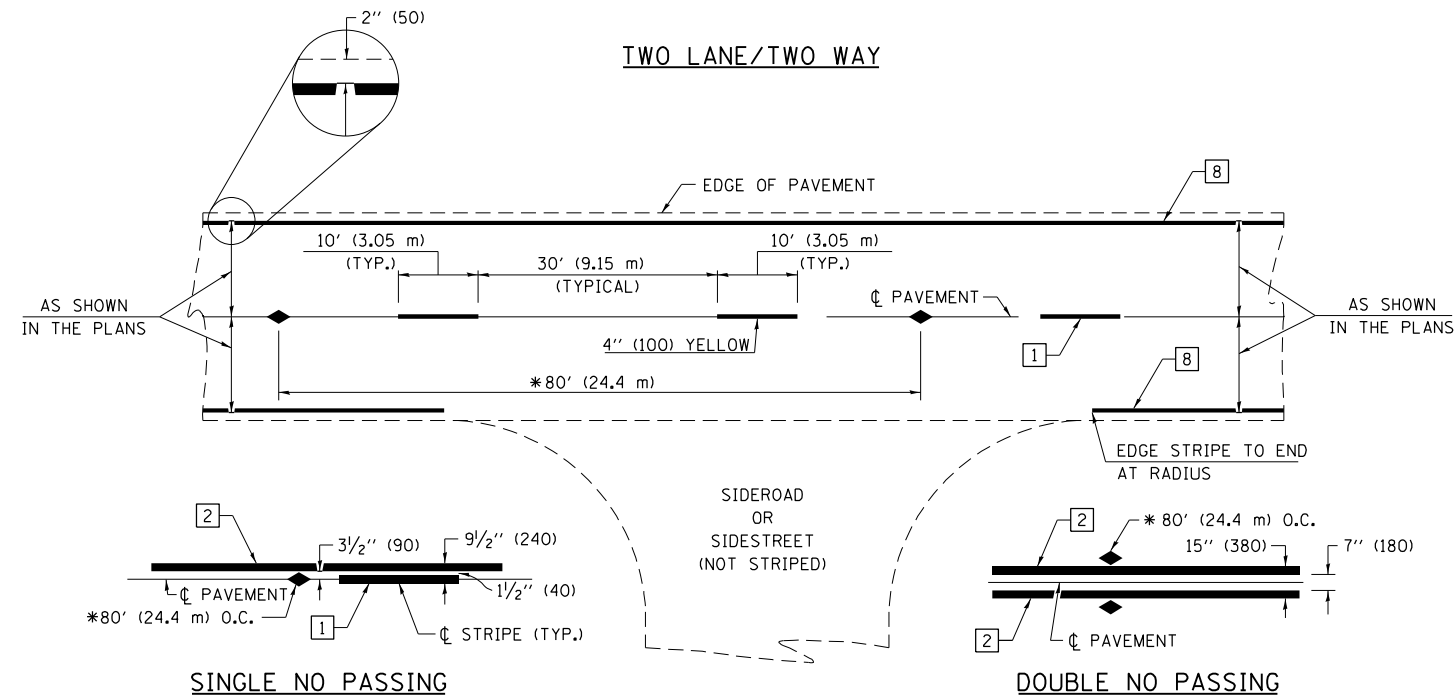

\* REDUCE TO 40' (12.2 m) O.C. ON CURVES WITH POSTED OR ADVISORY SPEEDS OF 45 mph (70 km/h) OR LESS.

**PAVEMENT MARKING LEGEND**

- 1 4" (100) SKIP-DASH (YELLOW)
  - 2 4" (100) SOLID (YELLOW)
  - 3 12" (300) DIAGONAL (YELLOW)
  - 4 4" (100) DOUBLE YELLOW (NARROW)
  - 5 12" (300) SOLID WHITE
  - 6 RESERVED
  - 7 6" (150) SKIP-DASH (WHITE)
  - 8 4" (100) SOLID (WHITE)
  - 9 12" (300) DIAGONAL (WHITE)
  - 10 6" (150) SOLID (WHITE)
  - 11 24" (600) STOP BAR (WHITE)
  - 12 8" (200) SOLID (WHITE)
  - 13 4" (100) PARKING WHITE
- 

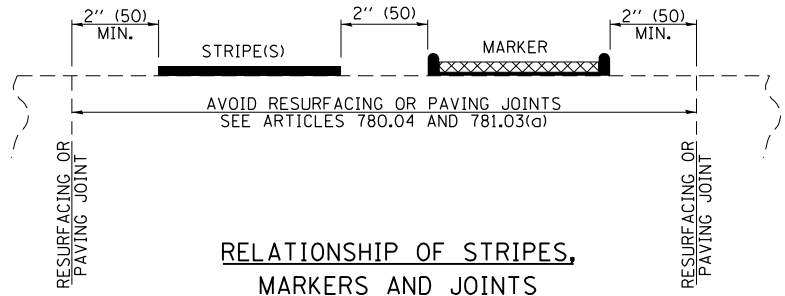

**TYPICAL PAVEMENT MARKERS LEGEND**

- ◆ TWO-WAY AMBER MARKER
- ▶ ONE-WAY AMBER MARKER
- ▷ ONE-WAY CRYSTAL MARKER

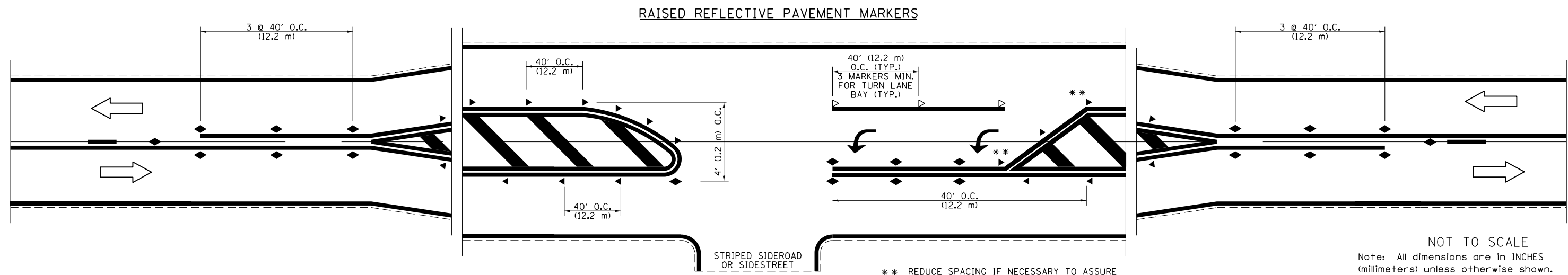

NOT TO SCALE  
Note: All dimensions are in INCHES (millimeters) unless otherwise shown.

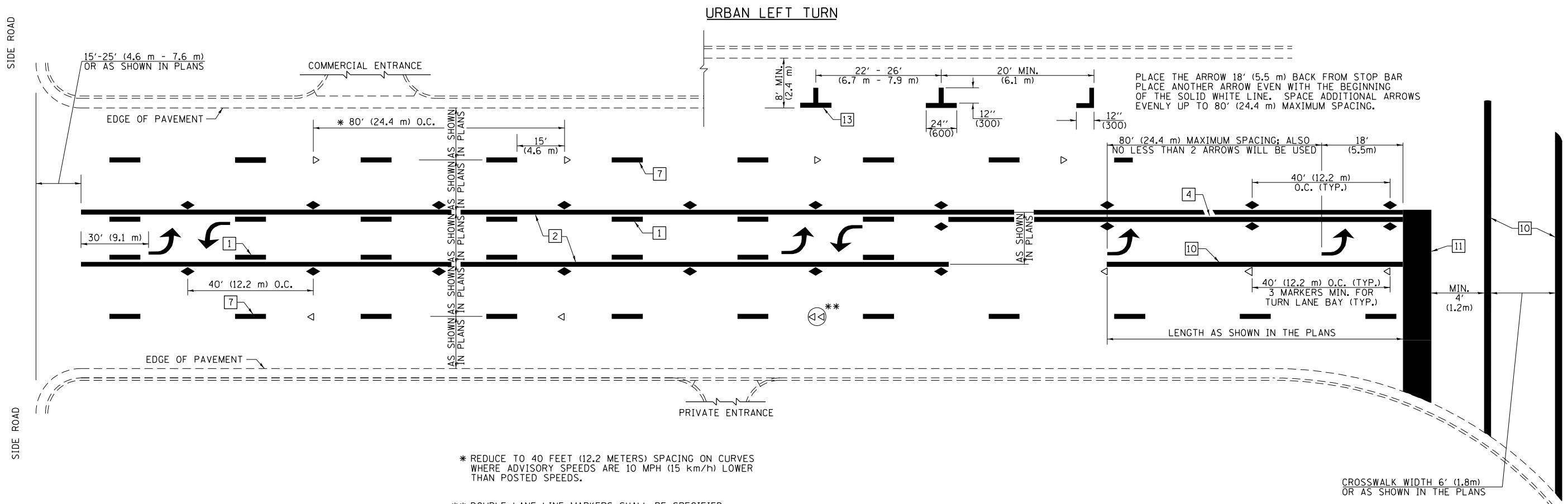

\* REDUCE TO 40 FEET (12.2 METERS) SPACING ON CURVES WHERE ADVISORY SPEEDS ARE 10 MPH (15 km/h) LOWER THAN POSTED SPEEDS.

\*\* DOUBLE LANE LINE MARKERS SHALL BE SPECIFIED AND SPACED AS SHOWN IN HIGHWAY STANDARD 781001 FOR MULTI-LANE DIVIDED AND UNDIVIDED HIGHWAYS.

**PAVEMENT MARKING LEGEND**

- 1 4" (100) SKIP-DASH (YELLOW)
- 2 4" (100) SOLID (YELLOW)
- 3 12" (300) DIAGONAL (YELLOW)
- 4 4" (100) DOUBLE YELLOW (NARROW)
- 5 12" (300) SOLID WHITE
- 6 RESERVED
- 7 6" (150) SKIP-DASH (WHITE)
- 8 4" (100) SOLID (WHITE)
- 9 12" (300) DIAGONAL (WHITE)
- 10 6" (150) SOLID (WHITE)
- 11 24" (600) STOP BAR (WHITE)
- 12 8" (200) SOLID (WHITE)
- 13 4" (100) PARKING WHITE

**GENERAL NOTES**

1. TURN ARROW PAIRS SHALL BE PLACED AT 250' (75 m) INTERVALS AND SHALL BE EVENLY SPACED BETWEEN BOTH ENDS OF THE BIDIRECTIONAL LEFT TURN LANE. USE A MINIMUM OF TWO PAIRS PER BLOCK.
2. THE SOLID YELLOW PAVEMENT MARKINGS [2] SHOULD GENERALLY START OR END NEAR THE RADIUS POINT OF EACH STREET RETURN EXCEPT WHERE ONE OR BOTH ENDS WOULD INCLUDE STOP BARS.
3. THE SKIP-DASH PAVEMENT MARKINGS [1] OR [7] SHOULD BE CENTERED BETWEEN BOTH ENDS OF EACH CITY BLOCK AND SHALL BE PLACED SO THEY LINE UP ACROSS FROM EACH OTHER.
4. USE LARGE ARROW SIZE FOR BOTH RURAL AND URBAN LOCATIONS. (SEE LAST PAGE OF SECTION 780x FOR SYMBOLS TABLE)
5. LANE LINE EXTENSIONS SHALL BE THE SAME COLOR AND WIDTH AS THE LANE LINE BEING EXTENDED.

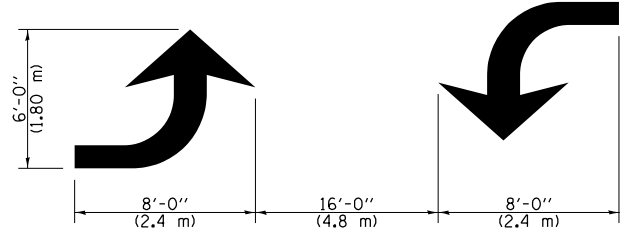
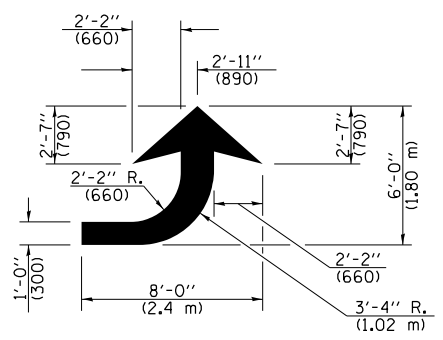
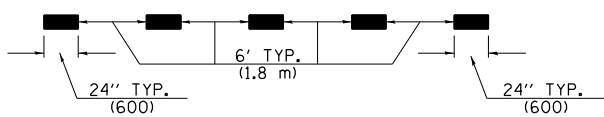
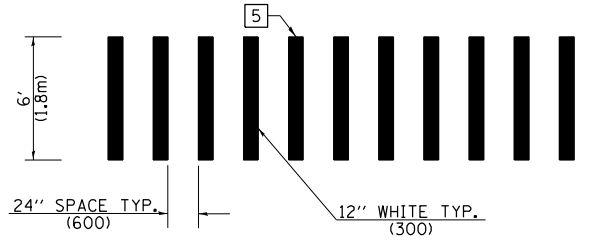

**TYPICAL DOUBLE TURN ARROWS (WHITE)**

**LEFT ARROW**  
REVERSE FOR RIGHT ARROW  
AREA = 15.6 SQ. FT. (1.47 m<sup>2</sup>)  
(WHITE)

NOT TO SCALE

Note: All dimensions are in INCHES (millimeters) unless otherwise shown.

**DISTRICT 7 DETAIL NO. 7800001**

FILE NAME =	USER NAME = Jessica.Hille	DESIGNED -	REVISED -	<b>STATE OF ILLINOIS DEPARTMENT OF TRANSPORTATION</b>	<b>PAVEMENT MARKING AND RAISED REFLECTIVE PAVEMENT MARKERS (RURAL &amp; URBAN APPLICATIONS)</b>	F.A.P. RTE.	SECTION	COUNTY	TOTAL SHEETS	SHEET NO.	
pw:\idot-pw\bentley.com\PWIDOT\Documents\IDOT Offices\District 7\Projects\7465\ICAD\Drawings\7465\shd-details.dgn	DRWN	REVISED -	REVISED -			821	(18BY)B	WAYNE	53	42	
PLOT SCALE = 100.0000' / 1"	CHECKED -	REVISED -	REVISED -			CONTRACT NO. 74651					
PLOT DATE = 3/29/2023	DATE -	REVISED -	REVISED -			ILLINOIS FED. AID PROJECT					
				SCALE:		SHEET NO. 2 OF 4 SHEETS		STA.		TO STA.	

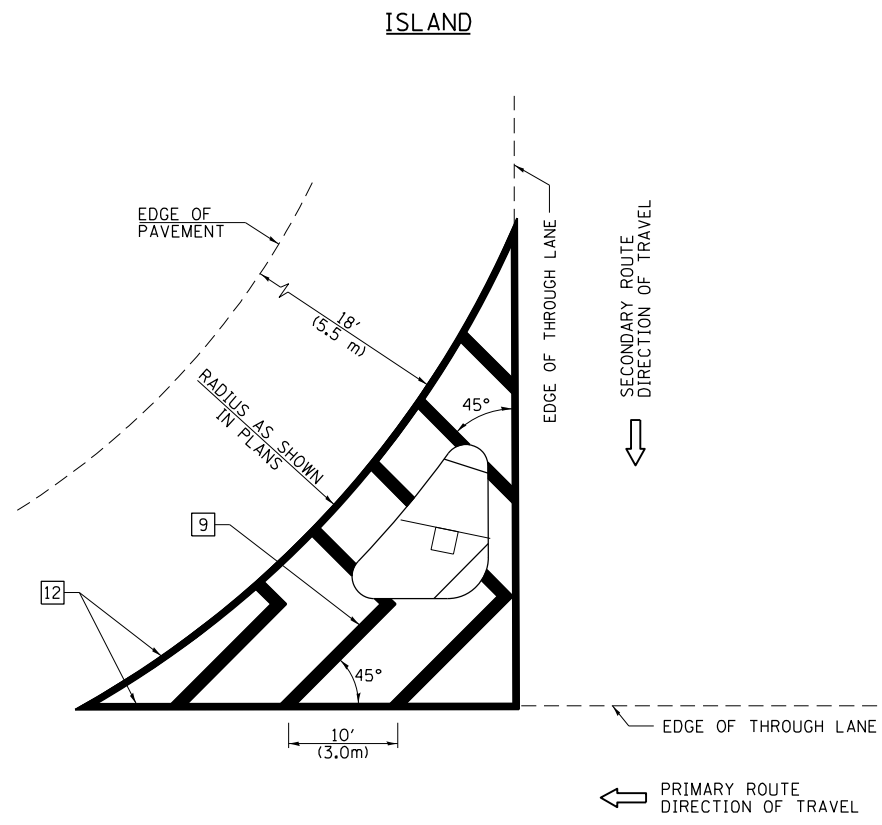

**GENERAL NOTES**

1. RAISED AND CORRUGATED MEDIANS SHALL BE OUTLINED WITH [2] IF PRESENT.
2. SOME OF THE INFORMATION INCLUDED WITH THIS DETAIL MAY NOT BE APPLICABLE TO THIS IMPROVEMENT.
3. PAVEMENT MARKINGS ARE TO BE EXTENDED THROUGH OMISSIONS WHEN APPLICABLE.
4. FINAL PAVEMENT MARKINGS SHALL BE IN PLACE PRIOR TO PLACING ANY RAISED REFLECTIVE PAVEMENT MARKERS.
5. THE FOLLOWING CRITERIA SHALL BE USED FOR SELECTING THE DIAGONAL PAVEMENT MARKING SPACING:
 

< 30 MPH (< 50 km/h)	15' (4.5 m)
30-45 MPH (50-75 km/h)	20' (6.0 m)
> 45 MPH (> 75 km/h)	30' (9.0 m)

**PAVEMENT MARKING LEGEND**

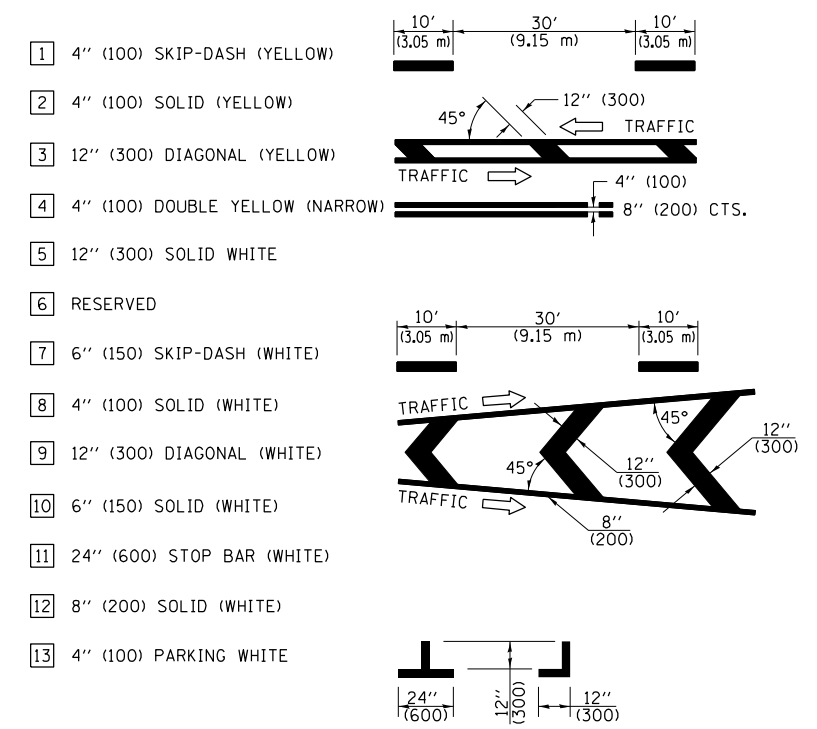

**RURAL LEFT TURN STRIPING**

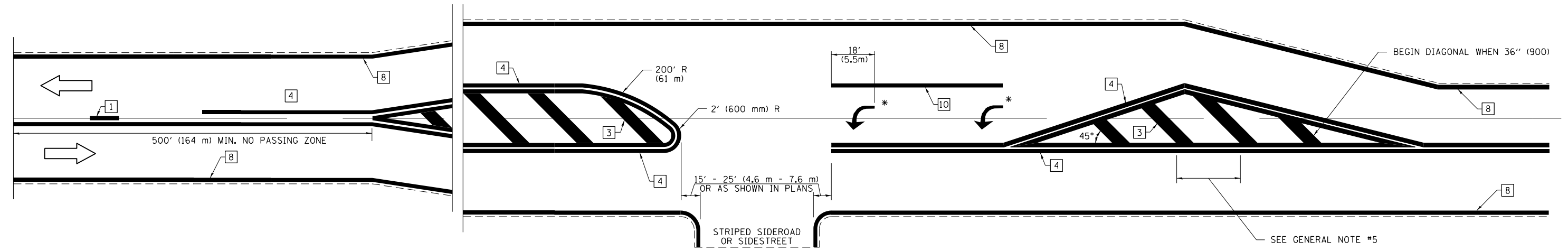

\* PLACE AN ARROW 18' (5.5 m) BACK FROM STOP BAR. PLACE ANOTHER ARROW EVEN WITH THE BEGINNING OF THE SOLID WHITE LINE. SPACE ADDITIONAL ARROWS EVENLY UP TO 80' (24.4 m) MAXIMUM SPACING. USE MINIMUM OF 2 ARROWS.

NOT TO SCALE  
 Note: All dimensions are in INCHES (millimeters) unless otherwise shown.

**DISTRICT 7 DETAIL NO. 7800001**

FILE NAME =	USER NAME = Jessica.Hille	DESIGNED -	REVISED -
pw:\idot-pw.bentley.com\PWIDOT\Documents\IDOT Offices\District 7\Projects\7465\CADD\Drawings\74651-sht-details.dgn		CHECKED -	REVISED -
		DATE -	REVISED -

**STATE OF ILLINOIS  
 DEPARTMENT OF TRANSPORTATION**

**PAVEMENT MARKING AND RAISED REFLECTIVE PAVEMENT MARKERS  
 (RURAL & URBAN APPLICATIONS)**

SCALE: SHEET NO. 3 OF 4 SHEETS STA. TO STA.

F.A.P. RTE.	SECTION	COUNTY	TOTAL SHEETS	SHEET NO.
821	(18BY)B	WAYNE	53	43
CONTRACT NO. 74651				
ILLINOIS FED. AID PROJECT				

PAVEMENT MARKINGS AT RAILROAD-HIGHWAY GRADE CROSSING

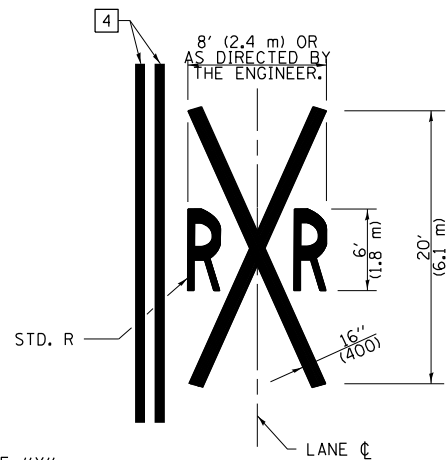
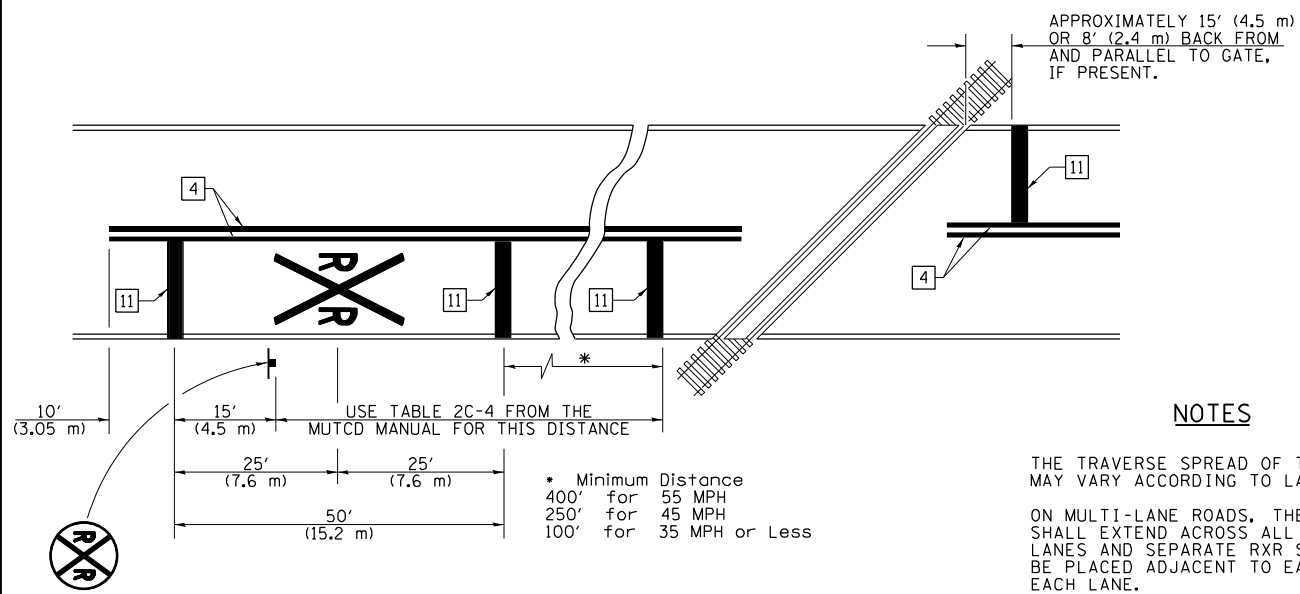

NOTES

THE TRAVERSE SPREAD OF THE "X" MAY VARY ACCORDING TO LANE WIDTH.

ON MULTI-LANE ROADS, THE STOP LINES SHALL EXTEND ACROSS ALL APPROACH LANES AND SEPARATE RXR SYMBOLS SHALL BE PLACED ADJACENT TO EACH OTHER IN EACH LANE.

WHEN THE PAVEMENT MARKING SYMBOL IS USED, A PORTION OF THE SYMBOL SHOULD BE LOCATED DIRECTLY ADJACENT TO THE ADVANCE WARNING SIGN (W10-1) AS PLACED BY TABLE II-1, CONDITION B OF THE MUTCD.

PAVEMENT MARKING LEGEND

- 1 4" (100) SKIP-DASH (YELLOW)
- 2 4" (100) SOLID (YELLOW)
- 3 12" (300) DIAGONAL (YELLOW)
- 4 4" (100) DOUBLE YELLOW (NARROW)
- 5 12" (300) SOLID WHITE
- 6 RESERVED
- 7 6" (150) SKIP-DASH (WHITE)
- 8 4" (100) SOLID (WHITE)
- 9 12" (300) DIAGONAL (WHITE)
- 10 6" (150) SOLID (WHITE)
- 11 24" (600) STOP BAR (WHITE)
- 12 8" (200) SOLID (WHITE)
- 13 4" (100) PARKING WHITE

RAILROAD CROSSING WITH INTERCONNECT ONLY

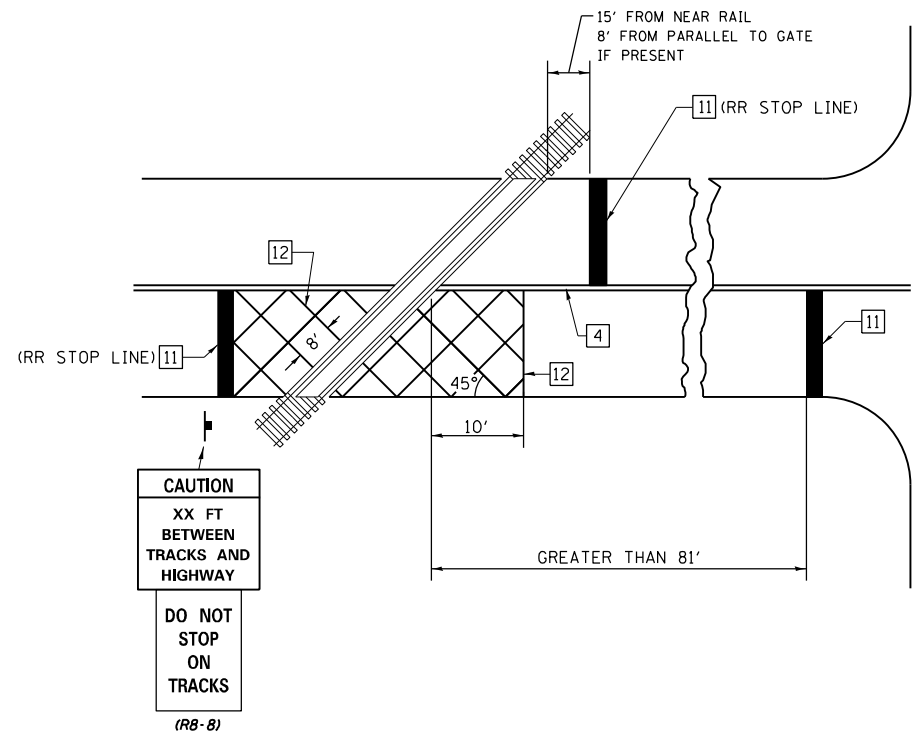

RAILROAD CROSSING WITH INTERCONNECT AND PRE-SIGNALS

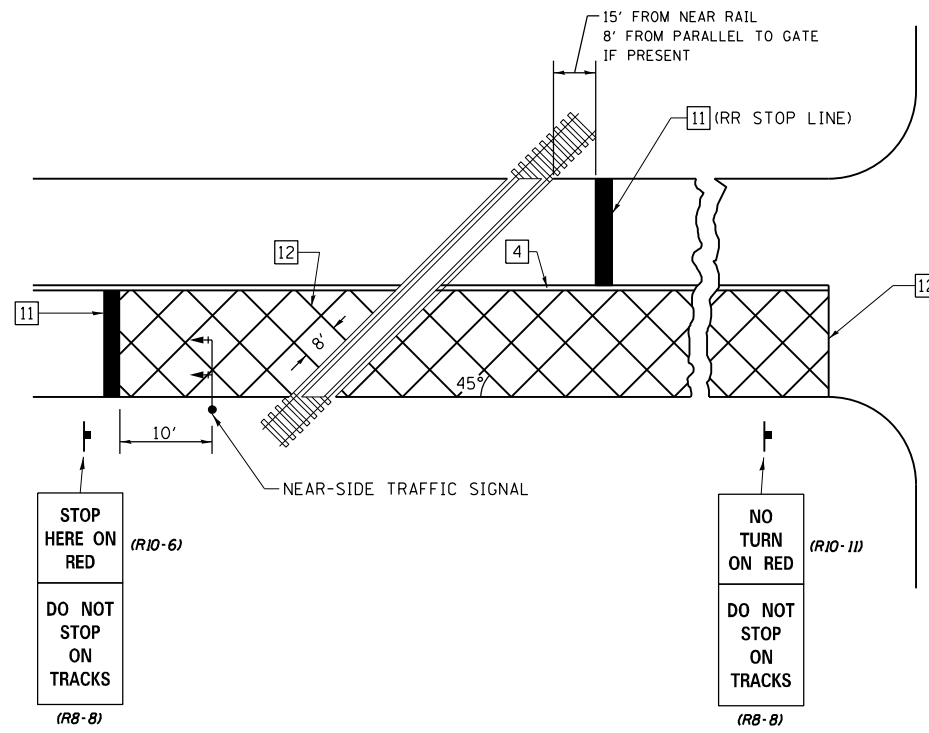

GENERAL NOTES

- SUPPLEMENTAL PAVEMENT MARKINGS TO BE INSTALLED ONLY ON APPROACHES TO INTERSECTIONS CONTROLLED BY TRAFFIC SIGNALS WHICH ARE INTERCONNECTED WITH THE RAILROAD WARNING SIGNALS.
- EXTEND PAVEMENT MARKINGS TO THE INTERSECTION ONLY WHERE NEAR-SIDE TRAFFIC SIGNALS ARE USED.

SUPPLEMENTAL PAVEMENT MARKING TREATMENT FOR RAILROAD-HIGHWAY GRADE CROSSING

NOT TO SCALE

Note: All dimensions are in INCHES (millimeters) unless otherwise shown.

DISTRICT 7 DETAIL NO. 7800001

FILE NAME =	USER NAME = Jessica.Hille	DESIGNED -	REVISED -	<b>STATE OF ILLINOIS DEPARTMENT OF TRANSPORTATION</b>	<b>PAVEMENT MARKING AND RAISED REFLECTIVE PAVEMENT MARKERS (RURAL &amp; URBAN APPLICATIONS)</b>	F.A.P. R.T.E.	SECTION	COUNTY	TOTAL SHEETS	SHEET NO.
pw:\idot-pw\bentley.com\PIWIDOT\Documents\IDOT Offices\District 7\Projects\74651\CADD\Drawings\74651-sht-details.dgn	PLotted	CHECKED -	REVISED -			821	(18BY)B	WAYNE	53	44
PLOT SCALE = 100.0000' / 1in.	DATE -	REVISED -	REVISED -			CONTRACT NO. 74651				
PLOT DATE = 3/29/2023	DATE -	REVISED -	REVISED -			ILLINOIS FED. AID PROJECT				

SCALE: SHEET NO. 4 OF 4 SHEETS STA. TO STA.



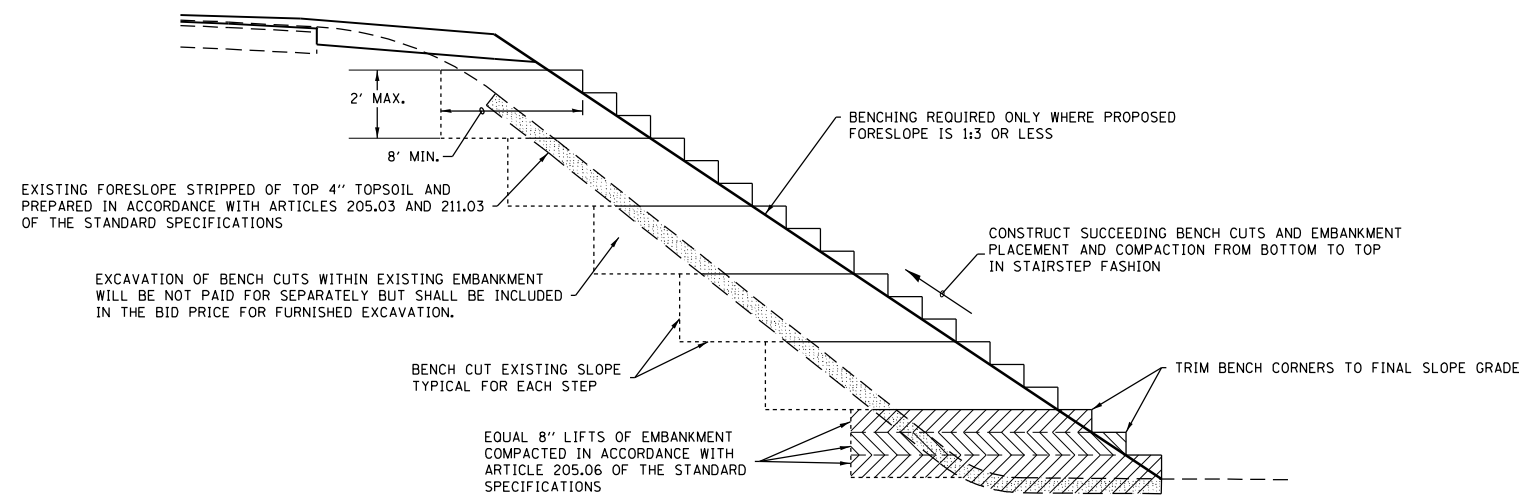

**TYPICAL BENCHING FOR EMBANKMENTS DETAIL**  
(NOT TO SCALE)

MODEL: Default  
 FILE: \\mllc-pw-bentley.com\PW\DOT\Documents\DOT Offices\District 7\Project\74651\CADD\Drawn\CAD\Sheets\0774651-sh-detailed.dgn

USER NAME = Jessica.Hille	DESIGNED -	REVISED -
	DRAWN -	REVISED -
PLOT SCALE = 100,0000 ' / in.	CHECKED -	REVISED -
PLOT DATE = 3/29/2023	DATE -	REVISED -

**STATE OF ILLINOIS  
DEPARTMENT OF TRANSPORTATION**

**MISC. DETAILS**

SCALE: NO SCALE SHEET 1 OF 1 SHEETS STA. TO STA.

F.A.P. RTE.	SECTION	COUNTY	TOTAL SHEETS	SHEET NO.
821	(188Y)B	WAYNE	53	46
CONTRACT NO. 74651			ILLINOIS FED. AID PROJECT	

DATE	
BY	
SURVEYED	
PLOTTED	
TEMPLATE	
AREAS CHECKED	
FINAL SURVEY	
NOTE BOOK	
NO.	

DATE	
BY	
SURVEYED	
PLOTTED	
TEMPLATE	
AREAS CHECKED	
ORIGINAL SURVEY	
NOTE BOOK	
NO.	

MODEL: D:\mfr\...  
 FILE NAME: D:\mfr\...  
 PROJECT: 74651

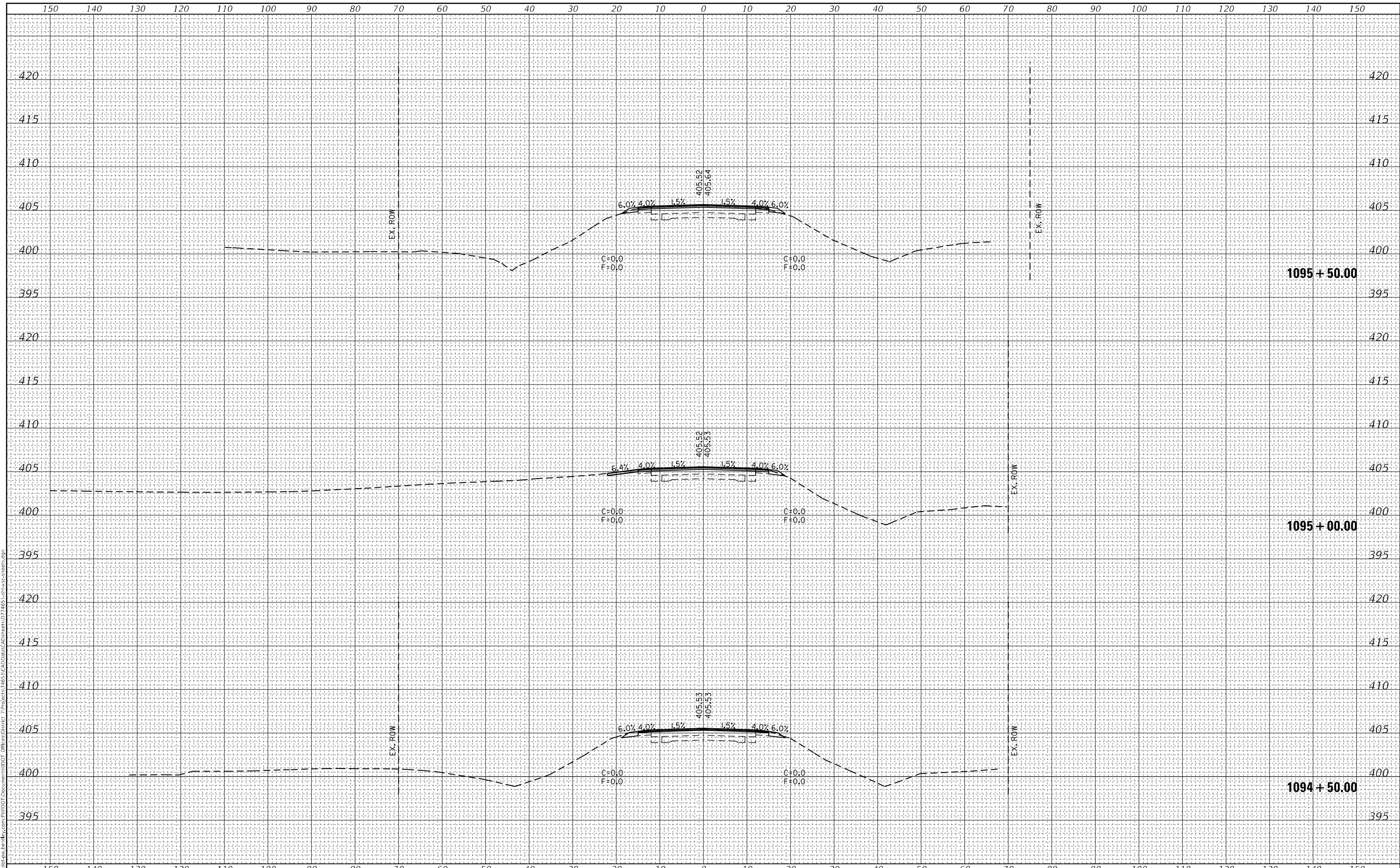

USER NAME = Jessica.Hille	DESIGNED -	REVISED -
	DRAWN -	REVISED -
PLOT SCALE = 20,0000 * / in.	CHECKED -	REVISED -
PLOT DATE = 3/29/2023	DATE -	REVISED -

**STATE OF ILLINOIS  
 DEPARTMENT OF TRANSPORTATION**

SCALE:	SHEET 1	OF 7	SHEETS	STA.	TO STA.
--------	---------	------	--------	------	---------

**CROSS  
 SECTIONS**

F.A.P. RTE.	SECTION	COUNTY	TOTAL SHEETS	SHEET NO.
821	(188Y)B	WAYNE	53	47
CONTRACT NO. 74651				
ILLINOIS FED. AID PROJECT				

DATE	
BY	
SURVEYED	
PLOTTED	
TEMPLATE	
AREAS CHECKED	
FINAL SURVEY NO.	
NOTE BOOK NO.	
AREAS CHECKED	

DATE	
BY	
SURVEYED	
PLOTTED	
TEMPLATE	
AREAS CHECKED	
ORIGINAL SURVEY NO.	
NOTE BOOK NO.	
AREAS CHECKED	

MODEL: Definit  
 FILE NAME: D:\Illinois\paw\hills\com\p\WIDOT\Documents\DOT\Office\center\Project\7465\1\CAD\Draw\CAD\Sheet\07465\_1\188YB\cross-sections.dgn

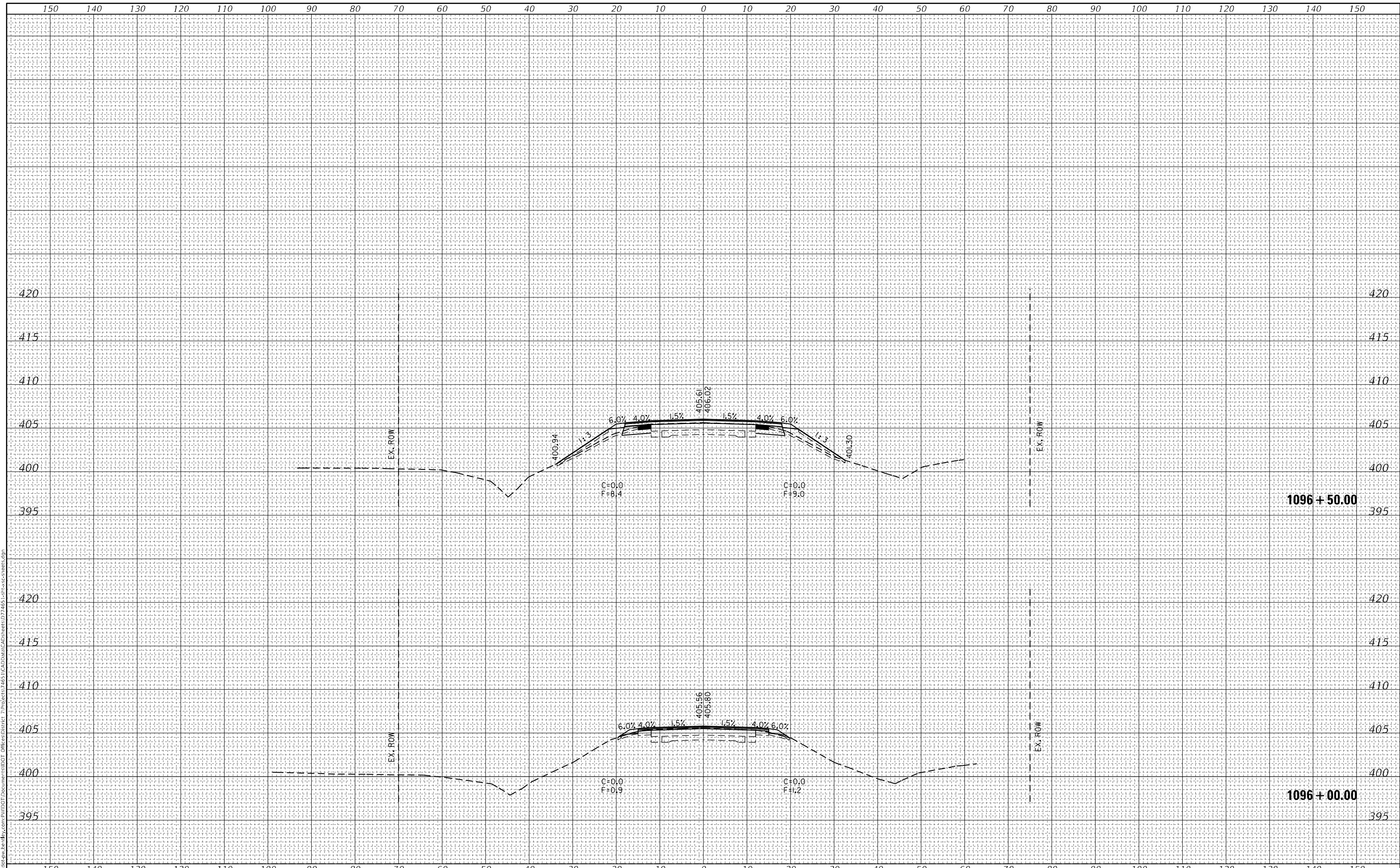

USER NAME = jessica.hille	DESIGNED -	REVISD -
	DRAWN -	REVISD -
PLOT SCALE = 20,0000 * / in.	CHECKED -	REVISD -
PLOT DATE = 3/29/2023	DATE -	REVISD -

**STATE OF ILLINOIS  
DEPARTMENT OF TRANSPORTATION**

<b>CROSS SECTIONS</b>	
SCALE:	SHEET 2 OF 7 SHEETS STA. TO STA.

F.A.P. RTE.	SECTION	COUNTY	TOTAL SHEETS	SHEET NO.
821	(188Y)B	WAYNE	53	48
CONTRACT NO. 74651				
ILLINOIS FED. AID PROJECT				



DATE	
BY	
FINAL SURVEY NO.	
SURVEYED	
PLOTTED	
TEMPLATE	
AREAS CHECKED	

DATE	
BY	
ORIGINAL SURVEY NO.	
SURVEYED	
PLOTTED	
TEMPLATE	
AREAS CHECKED	

MODEL: Definit  
 FILE NAME: D:\Illinois\paw\hillsby.com\PIV\DOT\Documents\DOT Office\Station\7485\1\CAD\Draw\CAD\Draw\7485\_1\188Y\188Y\188Y.dgn

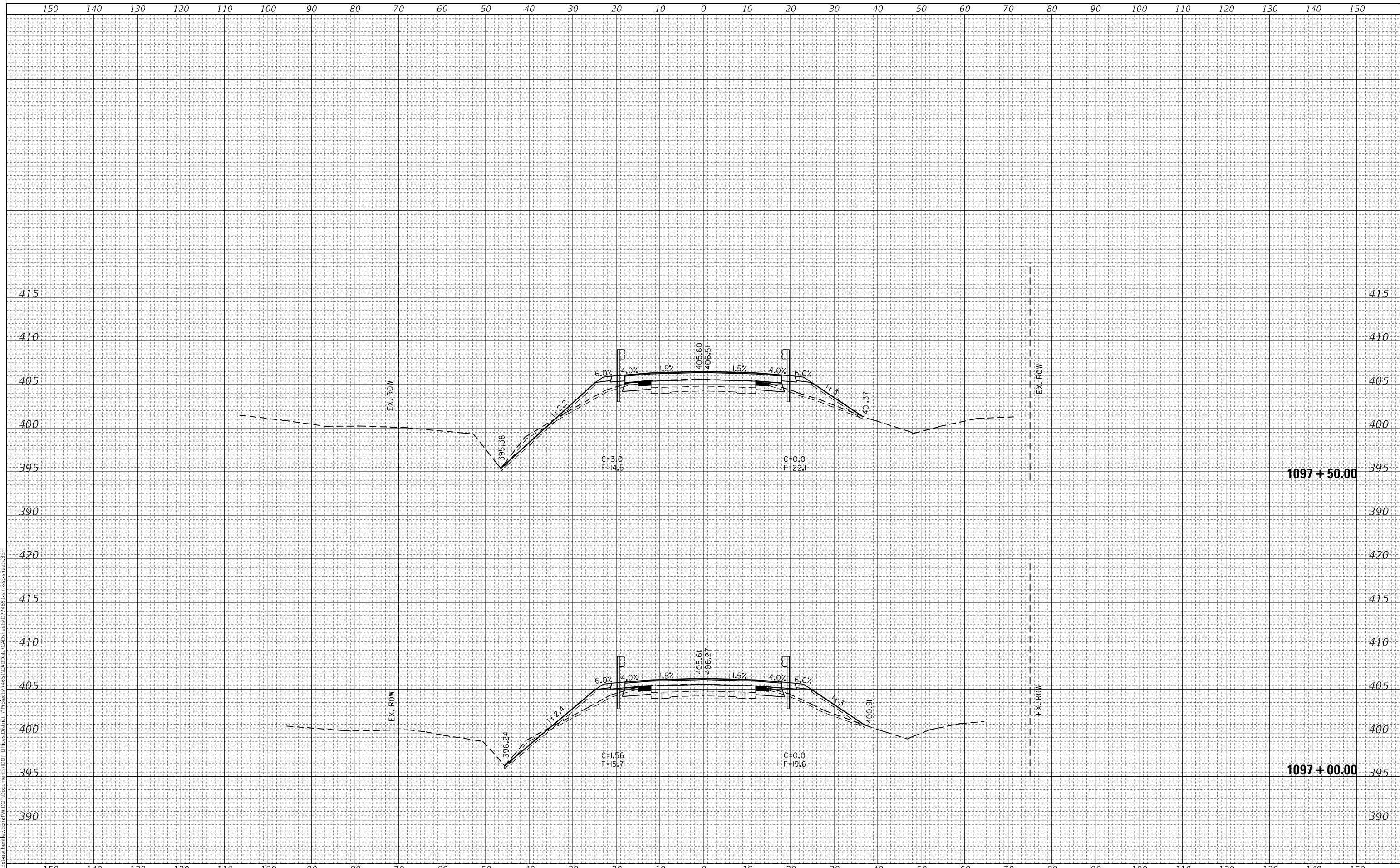

USER NAME = jessica.hille	DESIGNED -	REVISD -
	DRAWN -	REVISD -
PLOT SCALE = 20,0000 * / in.	CHECKED -	REVISD -
PLOT DATE = 3/29/2023	DATE -	REVISD -

**STATE OF ILLINOIS  
DEPARTMENT OF TRANSPORTATION**

**CROSS SECTIONS**

SCALE: SHEET 3 OF 7 SHEETS STA. TO STA.

F.A.P. RTE. 821	SECTION (188Y)B	COUNTY WAYNE	TOTAL SHEETS 53	SHEET NO. 49
CONTRACT NO. 74651				
ILLINOIS FED. AID PROJECT				

FINAL SURVEY NO.	SURVEYED	DATE
NOTE BOOK	PLOTTED	
AREAS CHECKED	TEMPLATE	
	AREAS CHECKED	

ORIGINAL SURVEY NO.	SURVEYED	DATE
NOTE BOOK	PLOTTED	
AREAS CHECKED	TEMPLATE	
	AREAS CHECKED	

MODEL: Definit  
 FILE NAME: d:\work\paw\hennelby.com\p\1\DOT\Documents\DOT Office\Station\74651\CAD\Draw\CAD\Draw\1074651.dwg

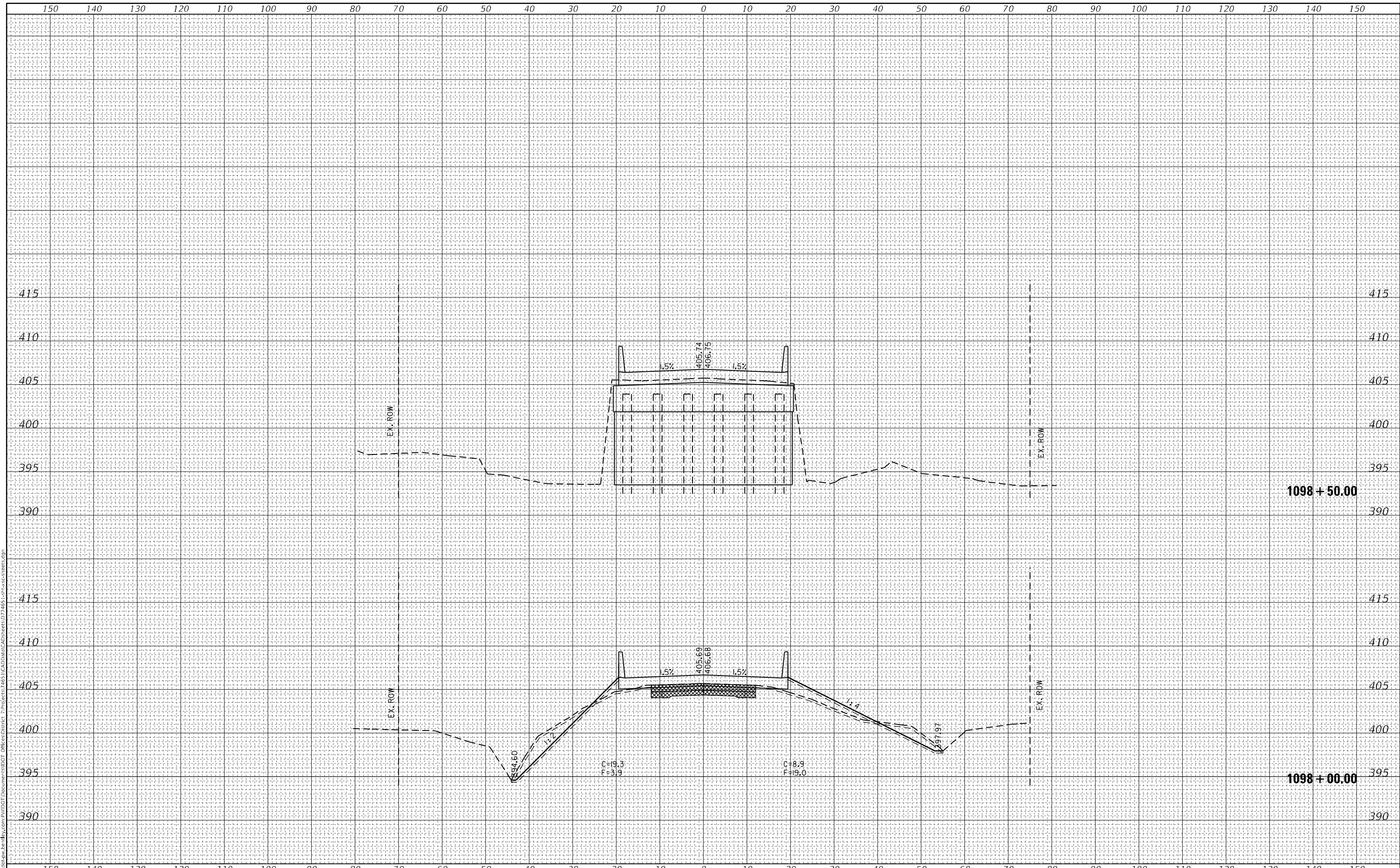

**STATE OF ILLINOIS  
 DEPARTMENT OF TRANSPORTATION**

**CROSS  
 SECTIONS**

USER NAME = jessica.hille	DESIGNED -	REVISED -
	DRAWN -	REVISED -
PLOT SCALE = 20,0000 * / in.	CHECKED -	REVISED -
PLOT DATE = 3/29/2023	DATE -	REVISED -

SCALE: SHEET 4 OF 7 SHEETS STA. TO STA.

F.A.P. RTE. 821	SECTION (188Y)B	COUNTY WAYNE	TOTAL SHEETS 53	SHEET NO. 50
CONTRACT NO. 74651				
ILLINOIS FED. AID PROJECT				

DATE	
BY	
FINAL SURVEY NO.	
SURVEYED	
PLOTTED	
TEMPLATE	
AREAS CHECKED	

DATE	
BY	
ORIGINAL SURVEY NO.	
SURVEYED	
PLOTTED	
TEMPLATE	
AREAS CHECKED	

MODEL: Definit  
 FILE NAME: D:\Illinois\pww\hills\com\pww\DOT\Documents\DOT Office\Printer - Proj\821\7451\CAD\Date\CAD\Sheet\07451-5-18-23-24-25.dgn

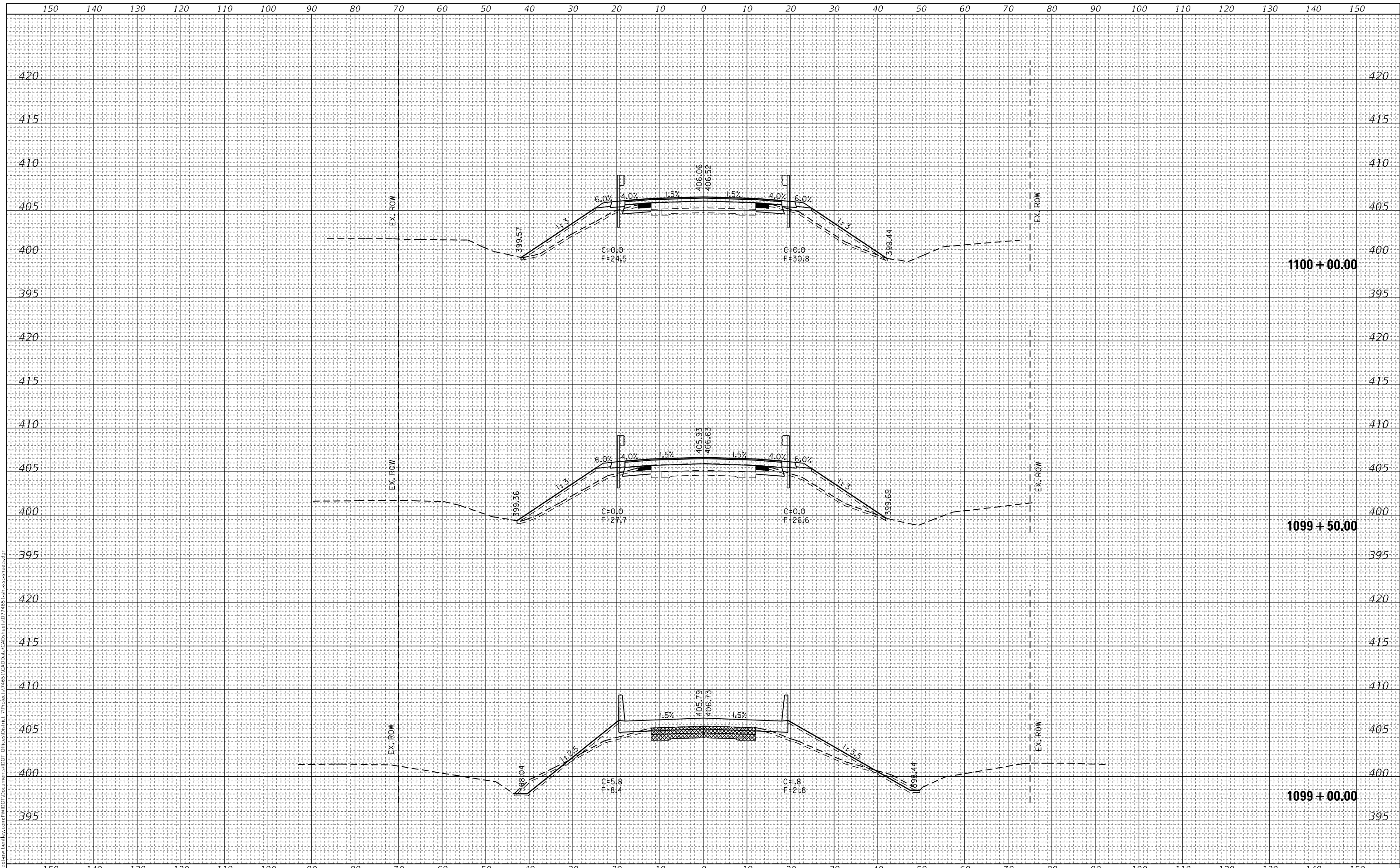

USER NAME = Jessica.Hille	DESIGNED -	REVISED -
	DRAWN -	REVISED -
PLOT SCALE = 20,0000 * / in.	CHECKED -	REVISED -
PLOT DATE = 3/29/2023	DATE -	REVISED -

**STATE OF ILLINOIS  
 DEPARTMENT OF TRANSPORTATION**

<b>CROSS SECTIONS</b>	
SCALE:	SHEET 5 OF 7 SHEETS STA. TO STA.

F.A.P. RTE. 821	SECTION (188Y)B	COUNTY WAYNE	TOTAL SHEETS 53	SHEET NO. 51
CONTRACT NO. 74651				
ILLINOIS FED. AID PROJECT				

DATE	
BY	
FINAL SURVEY	SURVEYED
NOTE BOOK	PLOTTED
NO.	TEMPLATE
	AREAS CHECKED

DATE	
BY	
ORIGINAL SURVEY	SURVEYED
NOTE BOOK	PLOTTED
NO.	TEMPLATE
	AREAS CHECKED

MODEL: Definit  
 FILE NAME: D:\Illinois\pww\hills\com\pww\DOT\Documents\DOT Office\Station\DOT Office\Station\74651\CAD\Drawings\74651-Cross-sections.dgn

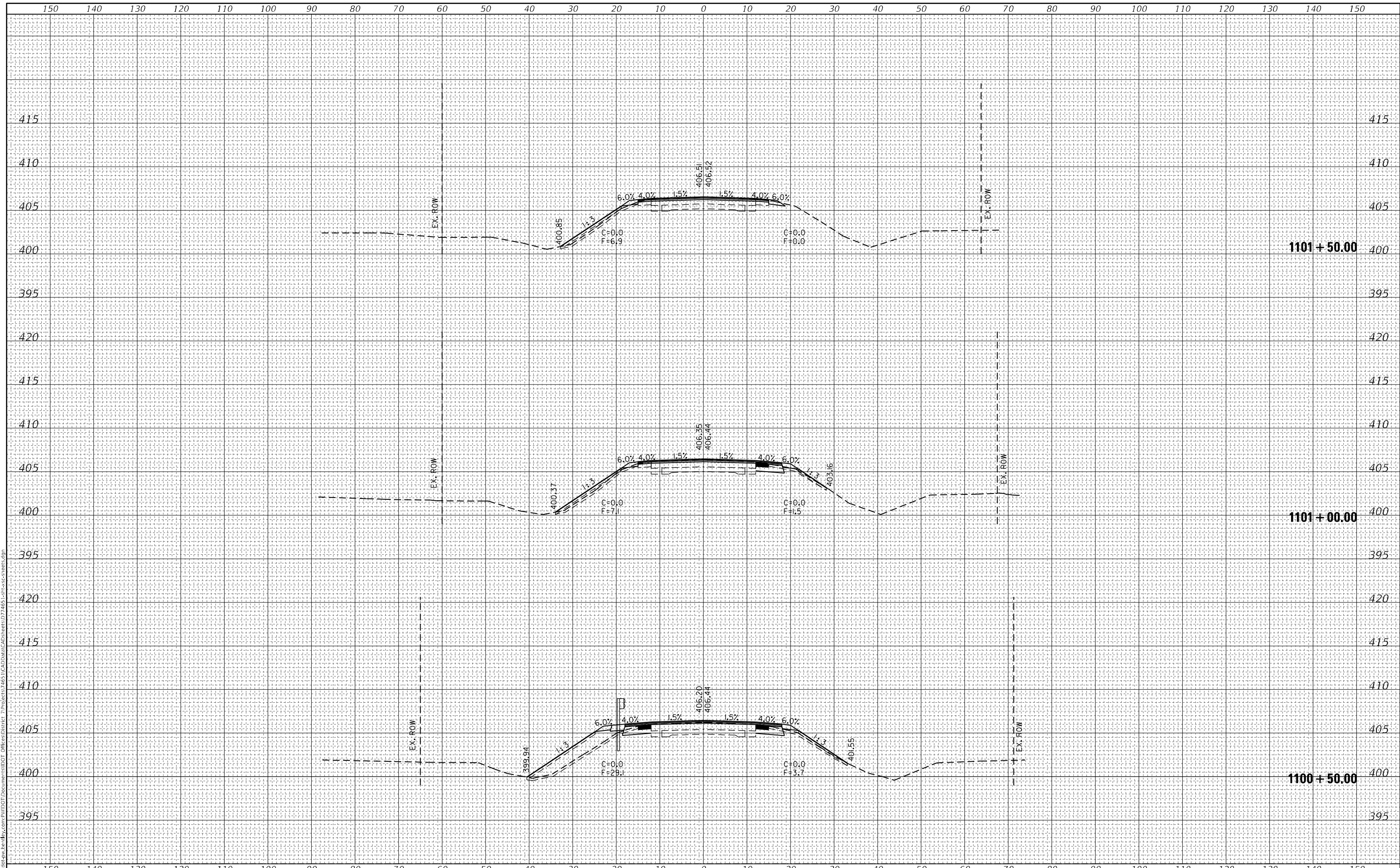

USER NAME = Jessica.Hille	DESIGNED -	REVISED -
	DRAWN -	REVISED -
PLOT SCALE = 20,0000' / in.	CHECKED -	REVISED -
PLOT DATE = 3/29/2023	DATE -	REVISED -

**STATE OF ILLINOIS  
DEPARTMENT OF TRANSPORTATION**

**CROSS SECTIONS**

SCALE: SHEET 6 OF 7 SHEETS STA. TO STA.

F.A.P. RTE.	SECTION	COUNTY	TOTAL SHEETS	SHEET NO.
821	(188Y)B	WAYNE	53	52
CONTRACT NO. 74651				
ILLINOIS FED. AID PROJECT				

FINAL SURVEY NO.	SURVEYED	DATE
NOTE BOOK	PLOTTED	
AREAS CHECKED	TEMPLATE	
	AREAS CHECKED	

ORIGINAL SURVEY NO.	SURVEYED	DATE
NOTE BOOK	PLOTTED	
AREAS CHECKED	TEMPLATE	
	AREAS CHECKED	

MODEL: Definit  
 FILE NAME: D:\Illinois\pww\hills.com\pww\DOT\Documents\DOT Office\Printer - Project\74651\CAD\Draw\CAD\Sheet\74651-53-188Y-B-188Y-B.dgn

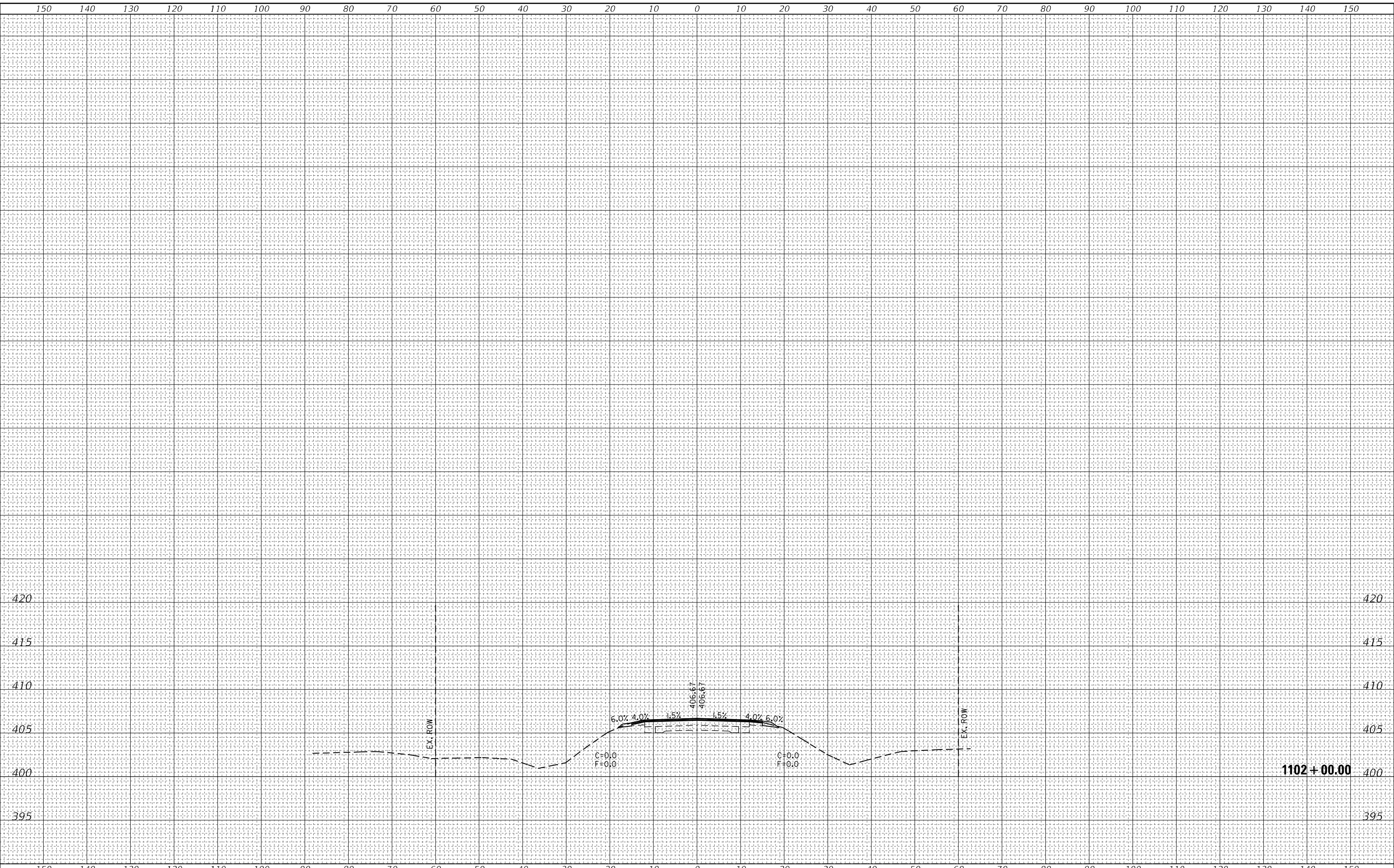

USER NAME = Jessica.Hille	DESIGNED -	REVISED -
	DRAWN -	REVISED -
PLOT SCALE = 20,0000 * / in.	CHECKED -	REVISED -
PLOT DATE = 3/29/2023	DATE -	REVISED -

**STATE OF ILLINOIS  
 DEPARTMENT OF TRANSPORTATION**

**CROSS SECTIONS**

SCALE: SHEET 7 OF 7 SHEETS STA. TO STA.

F.A.P. RTE. 821	SECTION (188Y)B	COUNTY WAYNE	TOTAL SHEETS 53	SHEET NO. 53
CONTRACT NO. 74651				
ILLINOIS FED. AID PROJECT				