

REF-  
REF-  
REF-

F.A.U. RTE.	SECTION	COUNTY	TOTAL SHEETS	SHEET NO.
2753	2004-050 RS	COOK	21	4
STA.		TO STA.		
FED. ROAD DIST. NO. 1 ILLINOIS HIGHWAY PROJECT				

CONTRACT #62763

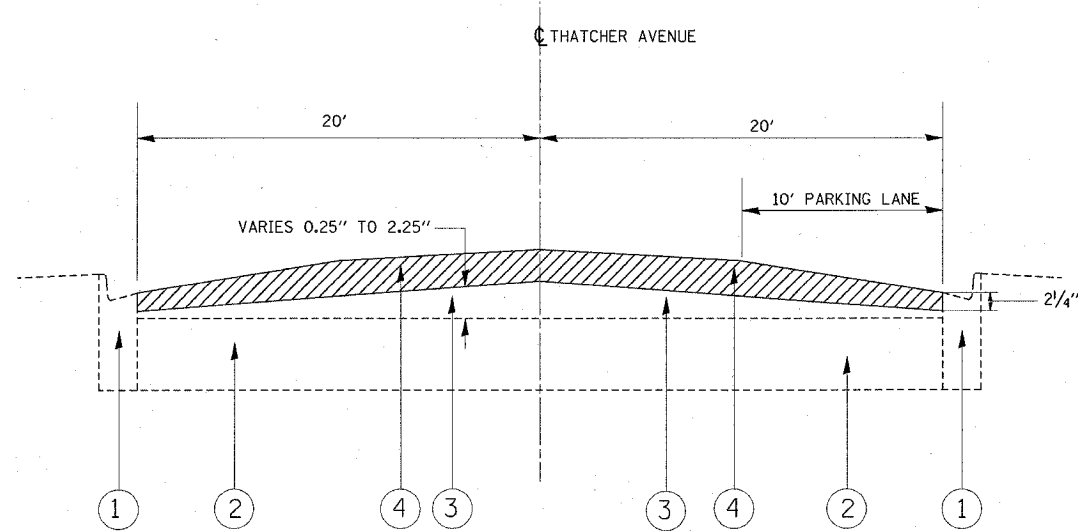

EXISTING TYPICAL SECTION  
THATCHER AVENUE  
STA. 0+21 TO STA. 26+18

**LEGEND:**

- ① EXISTING B-6.12 CURB & GUTTER
- ② EXISTING P.C.C. PAVEMENT, 8" (±)
- ③ EXISTING BITUMINOUS CONCRETE PAVEMENT, 4" (±)
- ④ PROPOSED BITUMINOUS SURFACE REMOVAL, 2 1/4"
- ⑤ PROPOSED BITUMINOUS CONCRETE SURFACE COURSE, SUPERPAVE, MIX "D", N50, 1 1/2"
- ⑥ PROPOSED POLYMERIZED LEVELING BINDER (MACHINE METHOD), SUPERPAVE, IL-4.75, N50, 3/4"

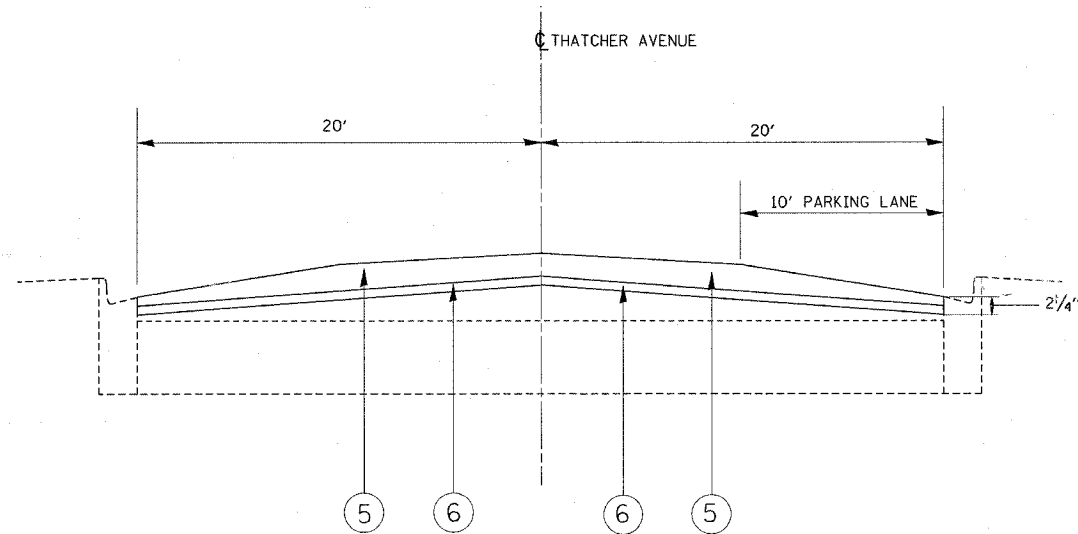

PROPOSED TYPICAL SECTION  
THATCHER AVENUE  
STA. 0+21 TO STA. 26+18

BITUMINOUS MIXTURE REQUIREMENTS

MIXTURE USE	AC/PG	MAX RAP. (%)	AIR VOIDS (%)
BIT. CONC. SURFACE COURSE, SUPERPAVE, MIX "D", N50	PG 64-22	15%	4% @ 50 GYR.
POLYMERIZED LEVELING BINDER (MACHINE METHOD) SUPERPAVE, IL-4.75, N50	SBS/SBR PG 76-28	0%	2.5% @ 50 GYR.
BIT. REPLACEMENT OVER PATCHES BINDER IL-19.0 MM	PG 64-22	15%	4% @ 70 GYR.
CLASS D PATCH BINDER IL-19.0 MM	PG 64-22	15%	4% @ 70 GYR.

REVISIONS		ILLINOIS DEPARTMENT OF TRANSPORTATION
NAME	DATE	
		<p style="text-align: center;"><b>THATCHER AVENUE</b> CHICAGO AVENUE TO DIVISION STREET EXISTING &amp; PROPOSED TYPICAL SECTIONS</p> <p>SCALE: VERT. NONE HORIZ. NONE DATE 4/8/2005</p> <p>DRAWN BY: APS CHECKED BY:</p>