

62877

F. A. NO.	SECTION	COUNTY	TOTAL SHEETS	SHEET NO.
290	0305-302K-L-3	COOK	55	40
STA.	TO STA.			
FED. ROAD DIST. NO. 1	BLK/NO.	FED. AID PROJ. NO.		

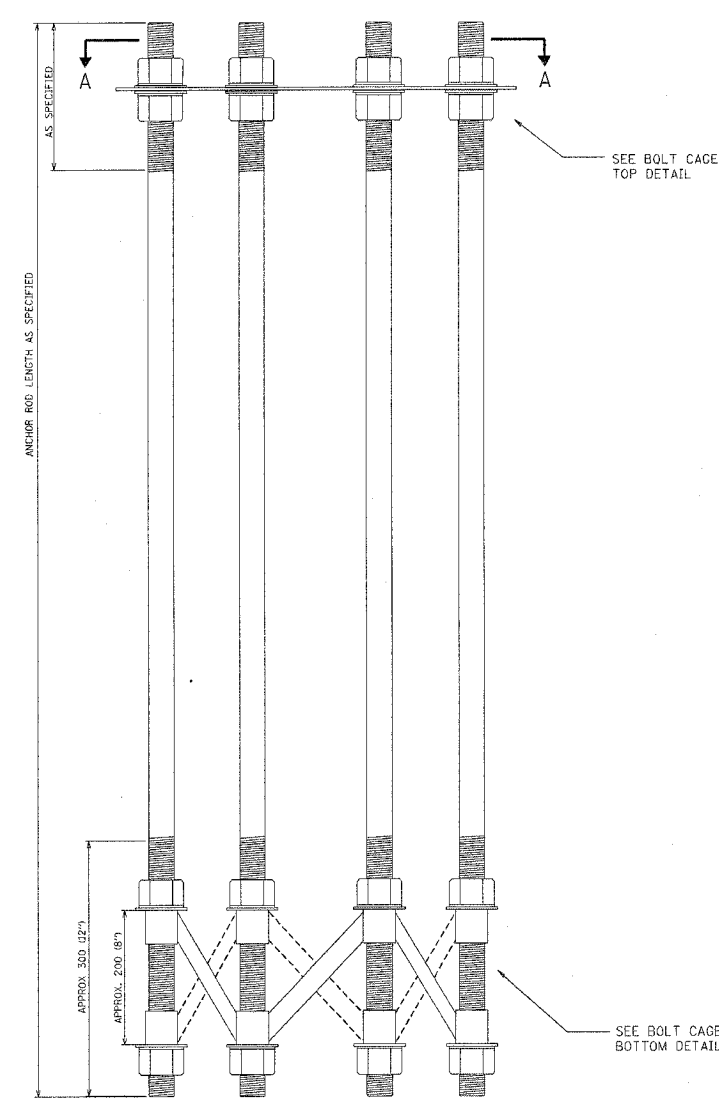

ANCHOR BOLT CAGE

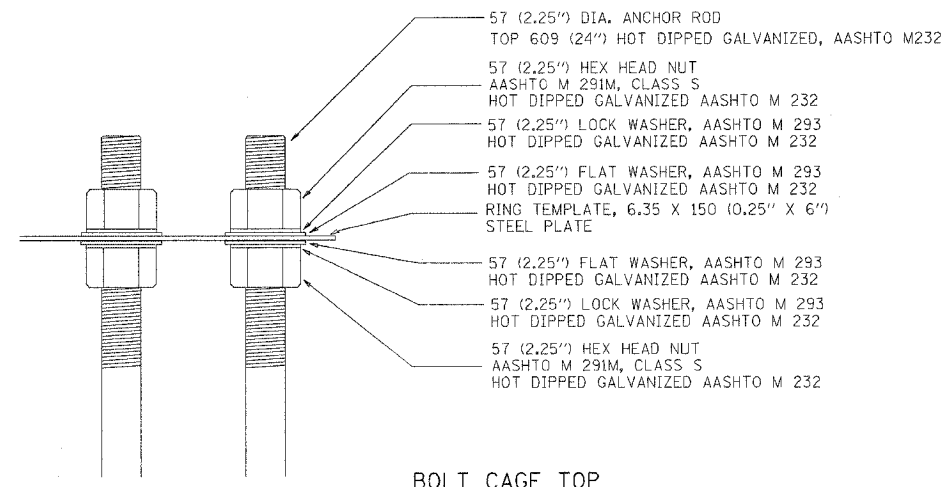

BOLT CAGE TOP

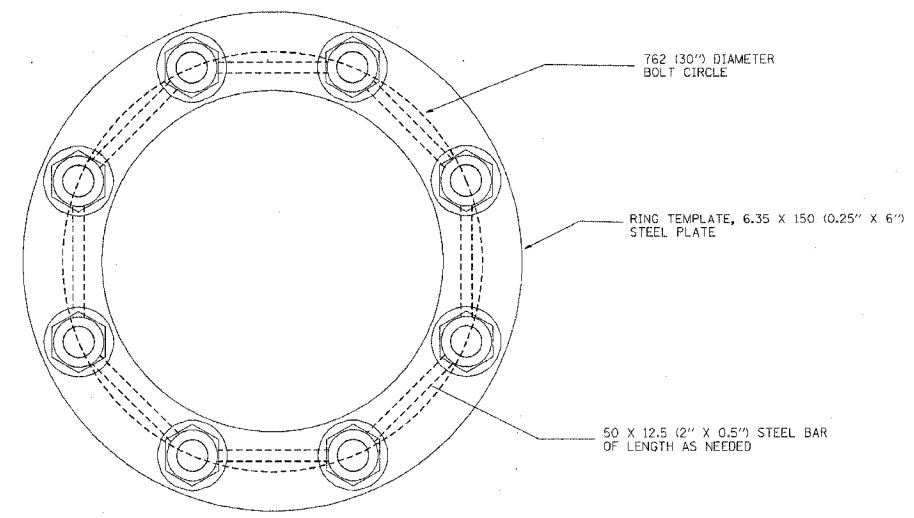

SECTION A-A

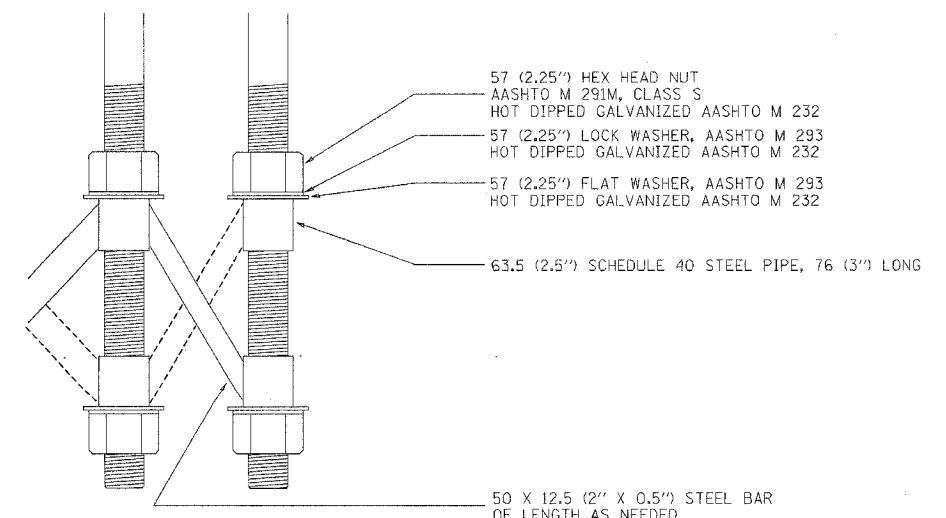

BOLT CAGE BOTTOM

NOTES

1. ALL DIMENSIONS IN MILLIMETERS (INCHES) UNLESS OTHERWISE SHOWN
2. ANCHOR RODS SHALL BE STRAIGHT AND SHALL BE ACCORDING TO AASHTO M 314 OR ASTM F1554, GRADE 725 (GRADE 105) AND GALVANIZED ACCORDING TO ARTICLE 1006.09.
3. ANCHOR ROD INFORMATION SHALL BE SUBMITTED FOR APPROVAL AND SHALL BE FULLY COORDINATED WITH TOWER MANUFACTURERS REQUIREMENTS.

REVISIONS	
NAME	DATE

BE501
ILLINOIS DEPARTMENT OF TRANSPORTATION
HIGH MAST LIGHT TOWER
27m TO 36m (90FT TO 120FT)
FOUNDATION DETAIL
SHEET 2 OF 2
SCALE: NONE
DATE 10/18/2002
DRAWN BY
CHECKED BY
BE08 (BE501)
REVISION DATE: 04/22/02

DATE-TIME
DGN-SPEC
VHBB