

CONTRACT NO 62920				
F.A.U.	SECTION	COUNTY	TOTAL SHEETS	SHEET NO.
3545	0303.1 RS	COOK	15	4
STA. 13+ 57		TO STA. 46+ 54		
FED. ROAD DIST. NO. 1 ILLINOIS FED. AID PROJECT				

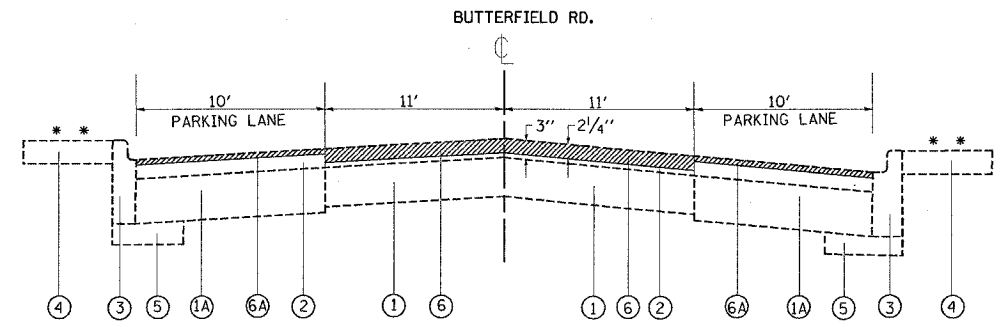

EXISTING TYPICAL SECTION
STA 13+57 TO STA 41+00

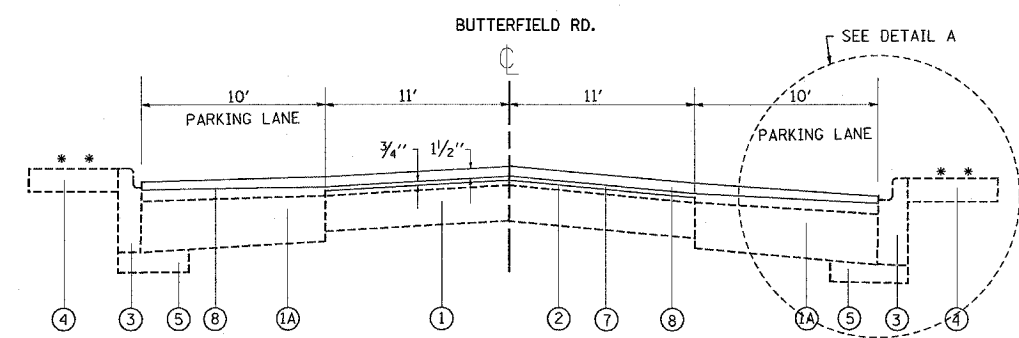

PROPOSED TYPICAL SECTION
STA 13+57 TO STA 41+00

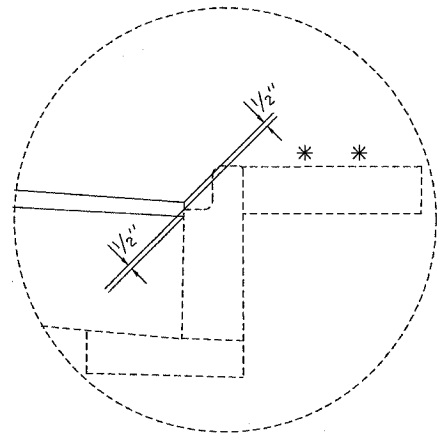

DETAIL A

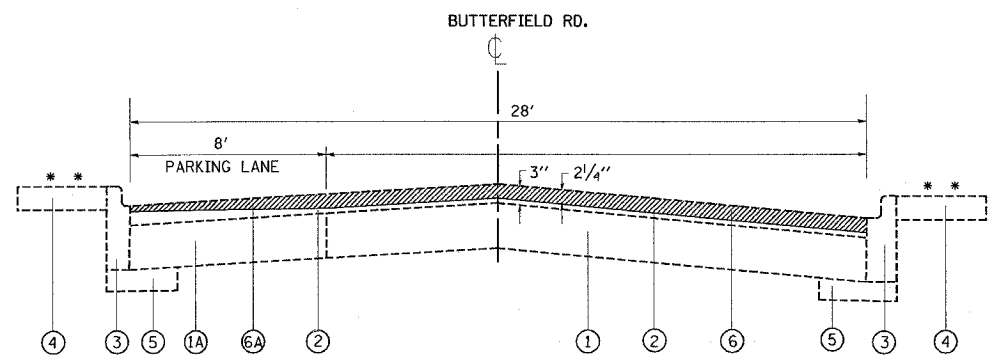

EXISTING TYPICAL SECTION
STA 41+00 TO STA 46+54

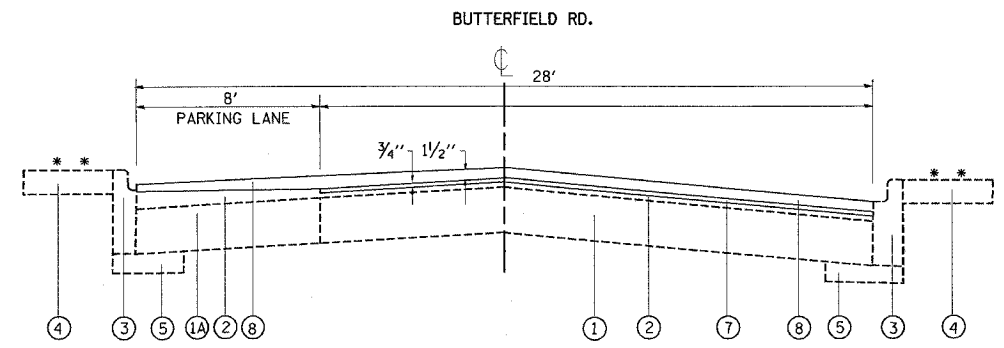

PROPOSED TYPICAL SECTION
STA 41+00 TO STA 46+54

LEGEND

- ① EXISTING PCC PAVEMENT 7"
- ①A EXISTING BITUMINOUS BASE COURSE 10"
- ② EXISTING BITUMINOUS SURFACE (AFTER MILLING)
- ③ EXISTING COMB. CONC. CURB AND GUTTER
- ④ EXISTING PCC SIDEWALK
- ⑤ EXISTING SUBBASE GRANULAR MATERIAL TYPE A
- ⑥ PROPOSED BITUMINOUS SURFACE REMOVAL (2 1/4")
- ⑥A PROPOSED BITUMINOUS SURFACE REMOVAL VARIABLE DEPTH (1 1/2" TO 1")
- ⑦ PROPOSED POLYMERIZED LEVELING BINDER (MACHINE METHOD), SUPERPAVE, IL-4.75 N50 (3/4")
- ⑧ PROPOSED BITUMINOUS CONCRETE SURFACE COURSE, SUPERPAVE, MIX "D", N50 (1 1/2")

REMOVAL

* * LOCATIONS VARIES

REVISIONS	
NAME	DATE

ILLINOIS DEPARTMENT OF TRANSPORTATION
BUTTERFIELD ROAD
(US 1220/45 TO ST. CHARLES RD.)
EXISTING AND PROPOSED
TYPICAL SECTIONS

SCALE: VERT. NONE
HORIZ. NONE

DATE: _____ DRAWN BY: JA
CHECKED BY: _____

05/06/2005