

F.A.S. RTE.	SECTION	COUNTY	TOTAL SHEETS	SHEET NO.
2079	16BR-M	OGLE	14	9
STA. TO STA.		FED. ROAD DIST. NO. ILLINOIS FED. AID PROJECT		

* Note: The contractor shall use extreme care during concrete removal so as not to damage the PPC Deck Beams

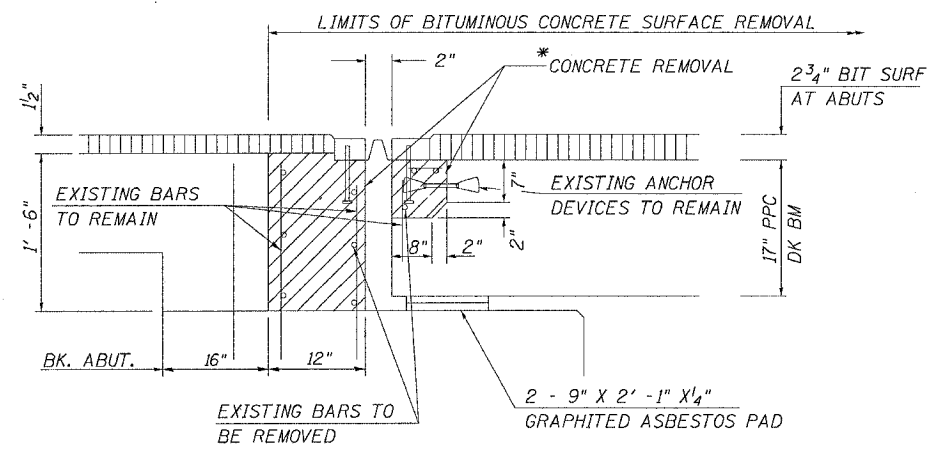

EXISTING SECTION THRU WEST ABUTMENT (EXPANSION)

NOTE: EXISTING REINFORCEMENT BARS & COIL LOOP ANCHOR DEVICES EXTENDING INTO THE REMOVAL AREAS SHALL BE CLEANED, STRAIGHTENED AND INCORPORATED INTO THE NEW CONSTRUCTION. ANY REINFORCEMENT BARS OR COIL LOOPS THAT ARE DAMAGED DURING CONCRETE REMOVAL SHALL BE REPLACED WITH APPROVED BAR SPLICER OR ANCHORAGE SYSTEM. COST INCLUDED WITH CONCRETE REMOVAL.

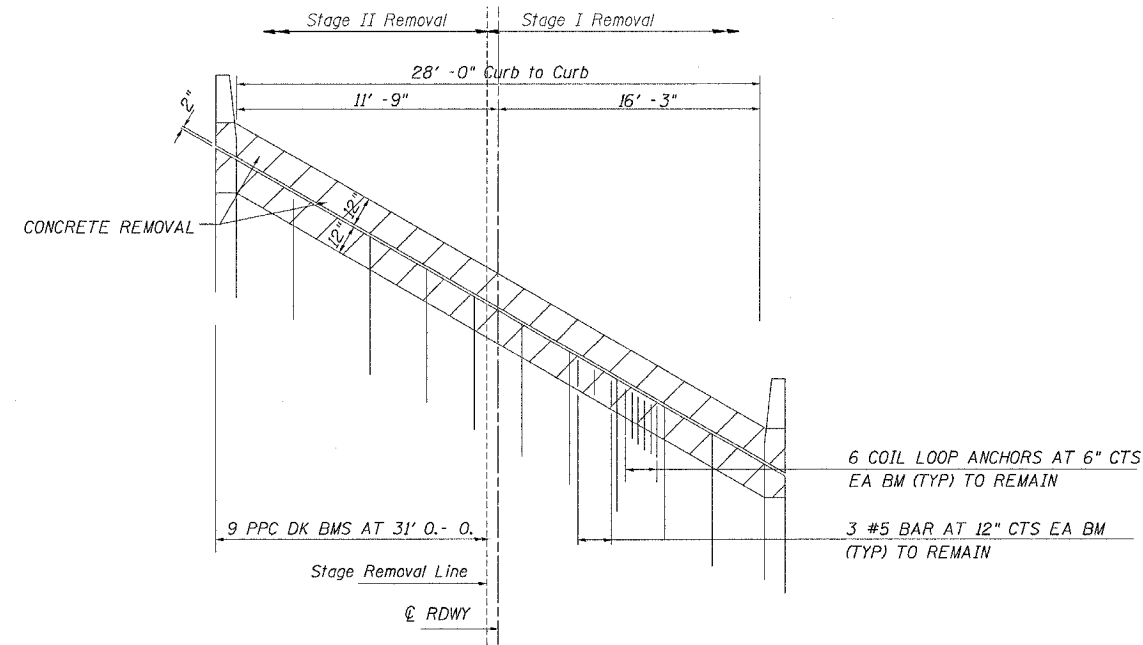

EXISTING PARTIAL PLAN (WEST ABUTMENT)

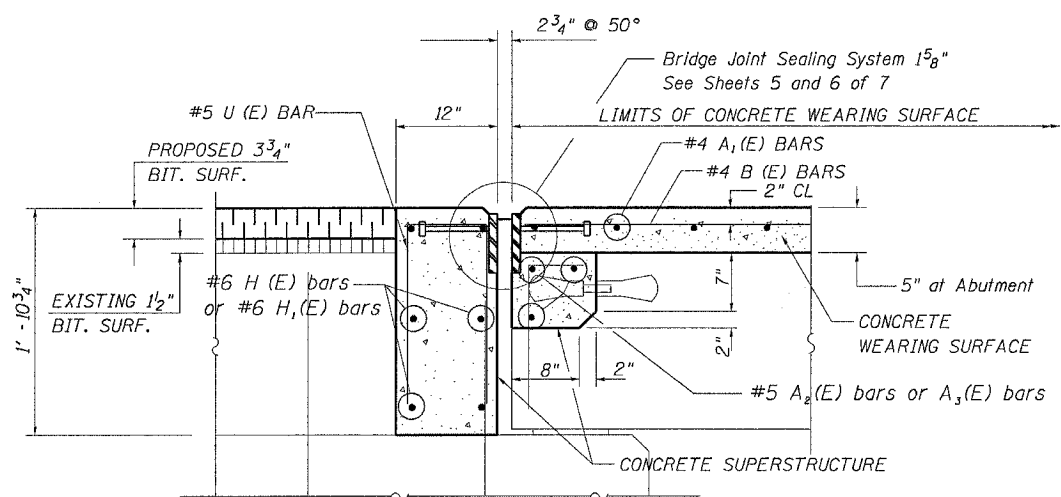
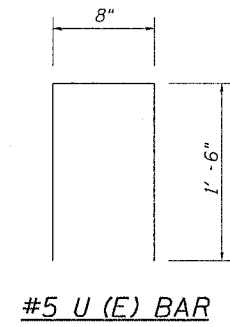

PROPOSED SECTION THRU WEST ABUTMENT (EXPANSION)

Note: Dimensions are based on PJS Joint. If the contractor elects to use the alternate strip seal, the dimensions may require adjustments as detailed on the joint base sheet.

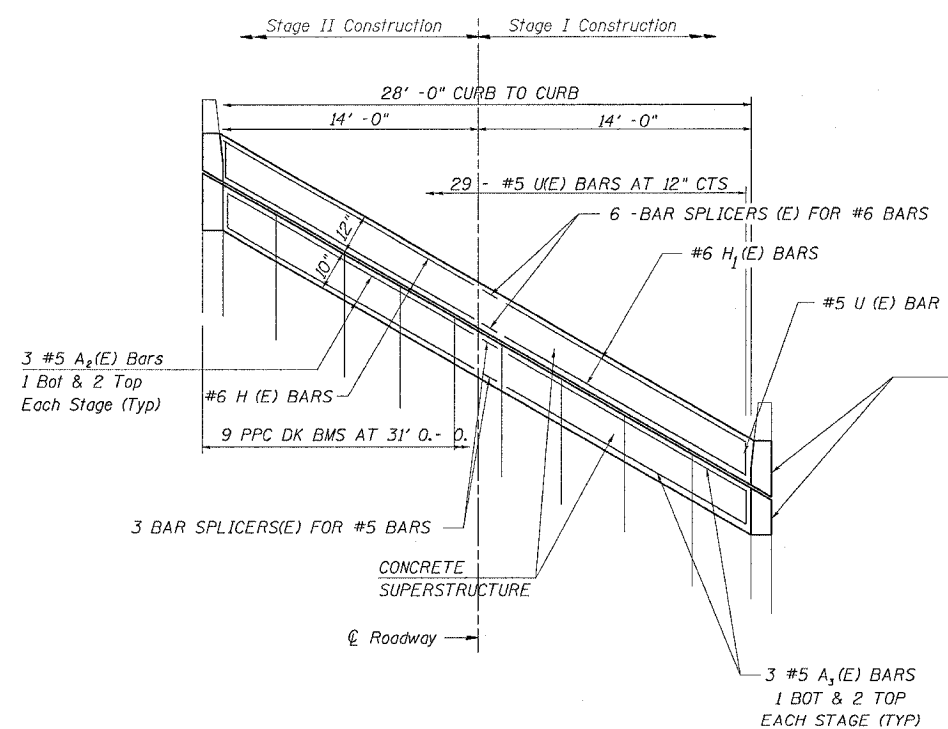

PROPOSED PARTIAL PLAN (WEST ABUTMENT)

Remove and replace concrete parapet for setting of expansion joint armor. Existing Reinforcement Bars extending into the removal areas shall be cleaned, straightened and incorporated into the new construction. Any Reinforcement bars that are damaged during concrete removal shall be replaced with approved bar splicer or anchorage system. Cost included in Bridge Joint System (Expansion), 1 5/8"

EXPANSION JOINT DETAILS
 US 52 OVER ELKHORN CREEK
 FAS ROUTE 2079 (US 52)
 SECTION 16BR-M
 OGLE COUNTY
 STRUCTURE NUMBER 071-0070