

STATE OF ILLINOIS
DEPARTMENT OF TRANSPORTATION

FAS	SECTION	COUNTY	TOTAL SHEETS	SHEET NO.	SHEET NO. 6
2079	**	OGLE	14	11	-7 SHEETS
FED. ROAD DIST. NO. 7	ILLINOIS	FED. AID PROJECT			

16BR-M

GENERAL NOTES

The strip seal shall be made continuous and shall have a minimum thickness of 1/4". The configuration of the strip seal shall match the configuration of the Locking Edge Rails.

The height and thickness of the Locking Edge Rails shown are minimum dimensions. The actual configuration of the Locking Edge Rails and matching strip seal may vary from manufacturer to manufacturer. Flanged edge rails will not be allowed.

Locking Edge Rails may be spliced at slope discontinuities and stage construction joints.

The manufacturer's recommended installation methods shall be followed.

The joint opening and deck dimensions detailed on the superstructure are based on a preformed joint seal. If the contractor elects to use the alternate strip seal joint, the opening and deck dimensions shall be modified according to the dimensions detailed on this sheet. Required modifications shall be made at no additional cost to the State.

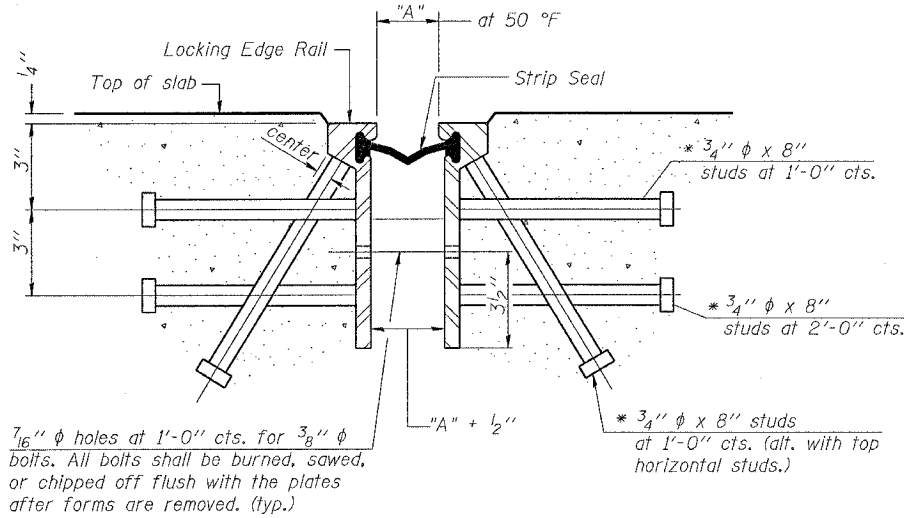

Required Strip Seal rated movement	"A"
1"	1 1/8"
2"	1 3/4"

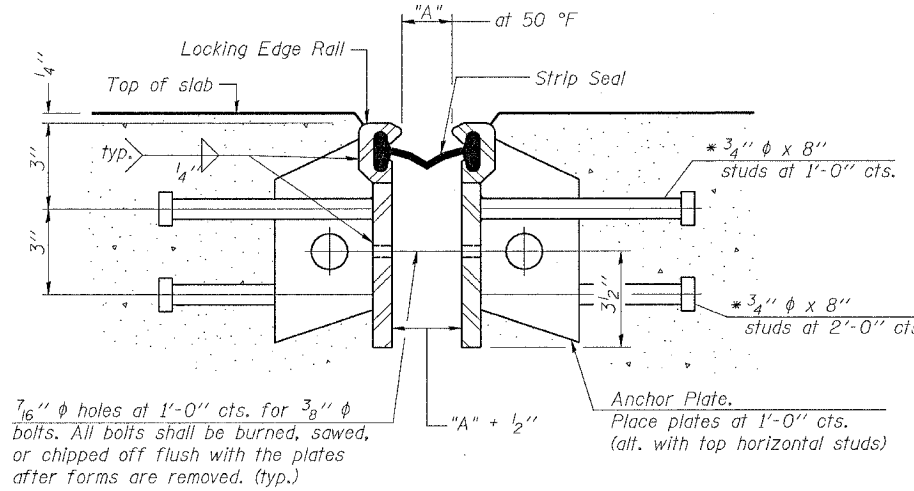

SECTION THRU ROLLED RAIL EXP. JOINT
(Studs Required)

SECTION THRU WELDED RAIL EXP. JOINT
(Studs Required)
(Anchor Plates Required)

* Granular or solid flux filled headed studs conforming to Article 1006.32 of the Std. Specs., automatically end welded.

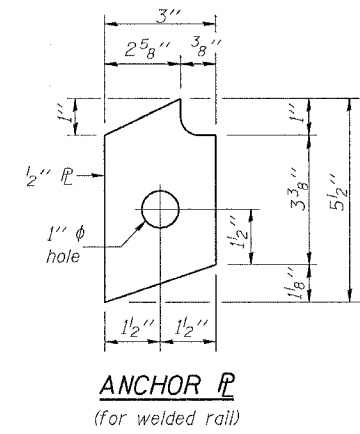
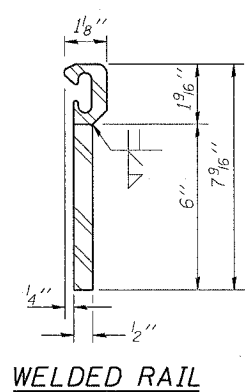
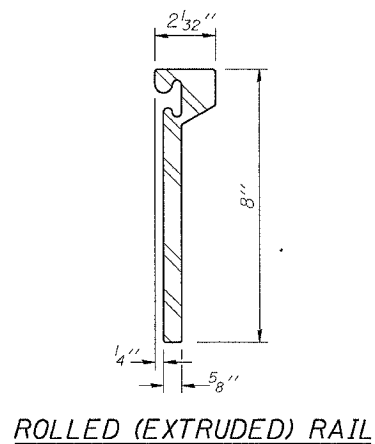

ROLLED (EXTRUDED) RAIL

WELDED RAIL

ANCHOR PL
(for welded rail)

LOCKING EDGE RAILS

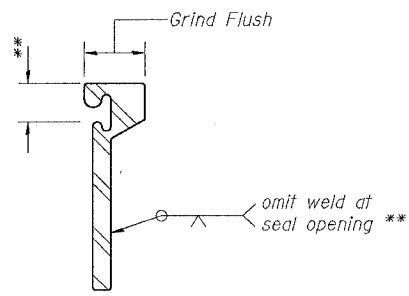

LOCKING EDGE RAIL SPLICE

The inside of the locking edge rail groove shall be free of weld residue.

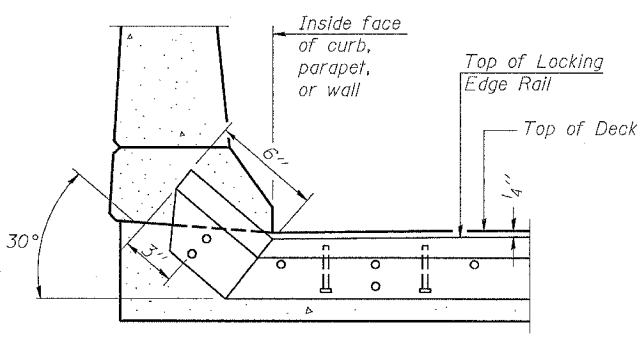

AT CURB, PARAPET, OR WALL

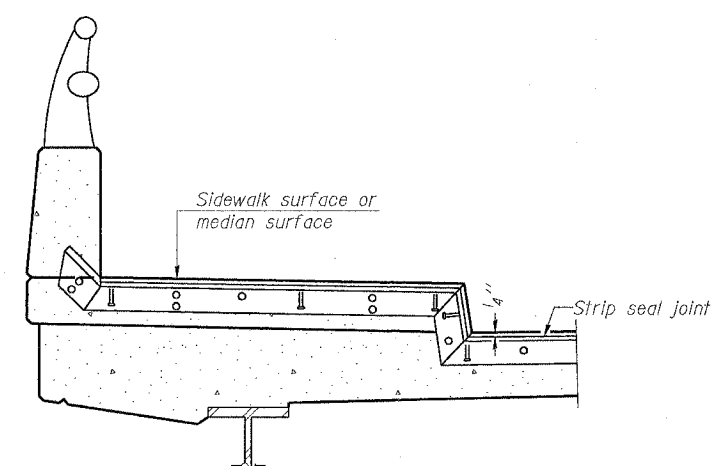

AT SIDEWALK OR MEDIAN*

TYPICAL END TREATMENTS

* Shorter plates with a single row of studs at 12" centers may be necessary on medians which are shallower than 9". See manufacturer's recommendation.

DESIGNED -	200
CHECKED -	EXAMINED
DRAWN -	PASSED
CHECKED -	ENGINEER OF STRUCTURAL SERVICES
	ENGINEER OF BRIDGES AND STRUCTURES

EJ-BJS 10-22-04

(Sheet 2 of 2)
BRIDGE JOINT SYSTEM - EXPANSION
(ALTERNATE-STRIP SEAL)
US 52 OVER ELKHORN CREEK
FAS ROUTE 2079 (US 52)
SECTION 16BR-M
OGLE COUNTY
STRUCTURE NUMBER 071-0070