

F.A.S. RTE.	SECTION	COUNTY	TOTAL SHEETS	SHEET NO.
2079	16BR-M	OGLE	14	13
STA.		TO STA.		
FED. ROAD DIST. NO.	ILLINOIS	FED. AID PROJECT		

DETAIL OF BITUMINOUS SHOULDER AT GUARD RAIL

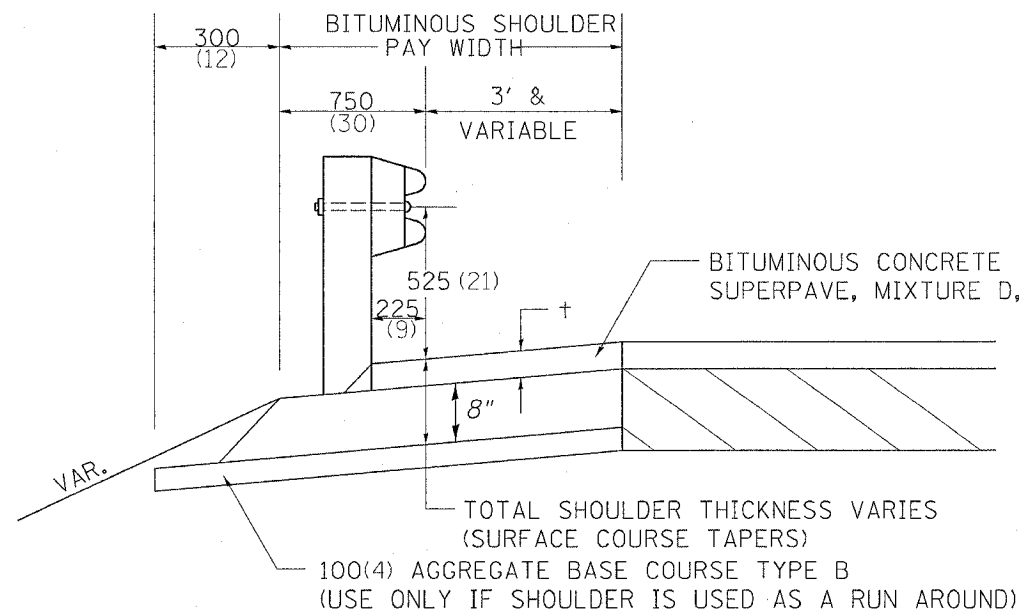

+ = SEE TYPICAL SECTIONS FOR THICKNESS

GENERAL NOTES

THE TOP LIFT SHALL NOT BE PLACED BEHIND THE GUARDRAIL POSTS. WHEN PLACING THE TOP LIFT THE RAIL MUST BE REMOVED FROM THE POSTS. THE POST SHALL NOT BE REMOVED.

THE HEIGHT OF THE GUARD RAIL SHALL BE SET (21) FROM THE FINISHED SURFACE.

THE BITUMINOUS SHOULDER SHALL BE CONSTRUCTED IN ACCORDANCE WITH SECTION 482 EXCEPT THE TOP LIFT SHALL BE BITUMINOUS CONCRETE SURFACE COURSE, SUPERPAVE, MIXTURE C, N50. THE WORK WILL BE PAID FOR AT THE CONTRACT UNIT PRICE PER TON FOR BITUMINOUS CONCRETE SURFACE COURSE, SUPERPAVE, MIXTURE C, N50, AND SQUARE METER (SQUARE YARD) FOR BITUMINOUS SHOULDERS SUPERPAVE OF THE THICKNESS SPECIFIED. THE REMOVAL & REINSTALLATION OF THE GUARDRAIL WILL BE INCLUDED IN THE COST OF THE BITUMINOUS CONCRETE SURFACE COURSE, SUPERPAVE, MIXTURE C, N50.

ALL DIMENSIONS ARE IN MILLIMETERS (INCHES) UNLESS OTHERWISE NOTED.

US 52 OVER ELKHORN CREEK
 FAS ROUTE 2079 (US 52)
 SECTION 16BR-M
 OGLE COUNTY
 STRUCTURE NUMBER 071-0070

DETAIL OF BITUMINOUS SHOULDER AT GUARD RAIL 23.4

REVISED 1-17-02