

STATE OF ILLINOIS
DEPARTMENT OF TRANSPORTATION

ROUTE NO.	SECTION	COUNTY	TOTAL SHEETS	SHEET	SHEET NO. 2
F.A.P.	*	Winnebago	36	15	9 SHEETS
FED. ROAD DIST. NO. 7	ILLINOIS	FED. AID PROJECT			

* (5VB, 5HB, 1-2HB)M CONTRACT #64A88

 Formed Conc. Rep. <5"

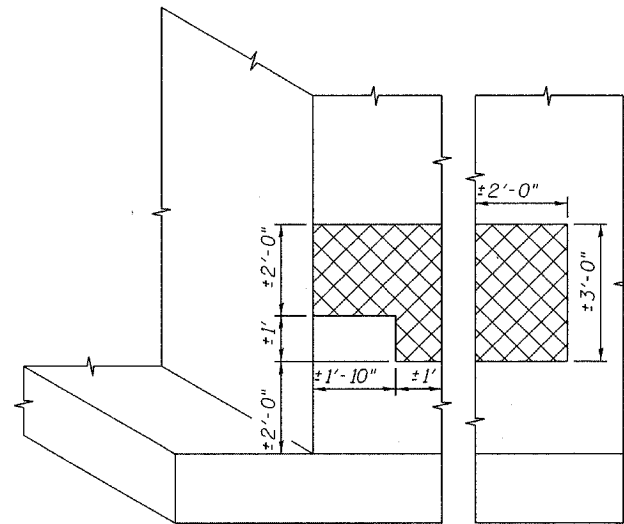

W. END ABUT. BK. WALL **W. WING WALL**
S. ABUTMENT - CORNER ELEV.
S.N. 101-0029

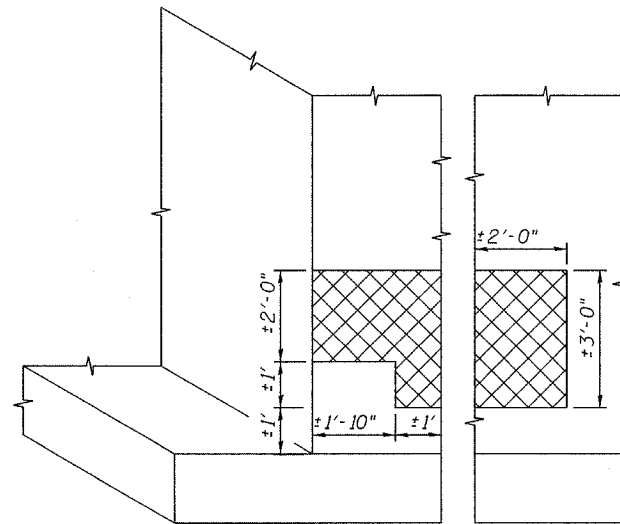

E. END ABUT. BK. WALL **E. WING WALL**
S. ABUTMENT - CORNER ELEV.
S.N. 101-0029

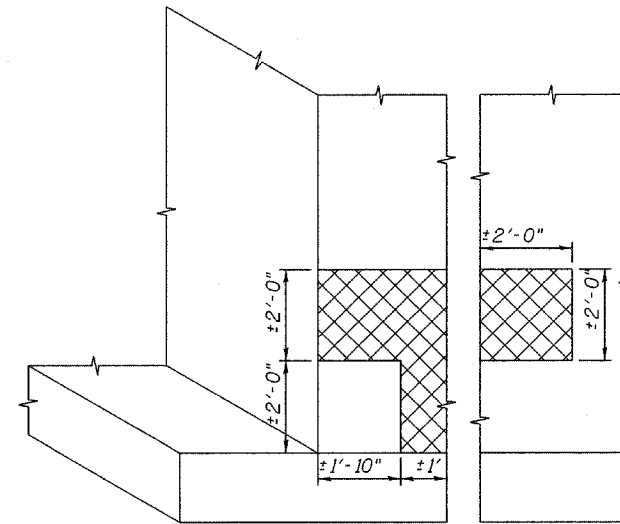

E. END ABUT. BK. WALL **E. WING WALL**
N. ABUTMENT - CORNER ELEV.
S.N. 101-0030

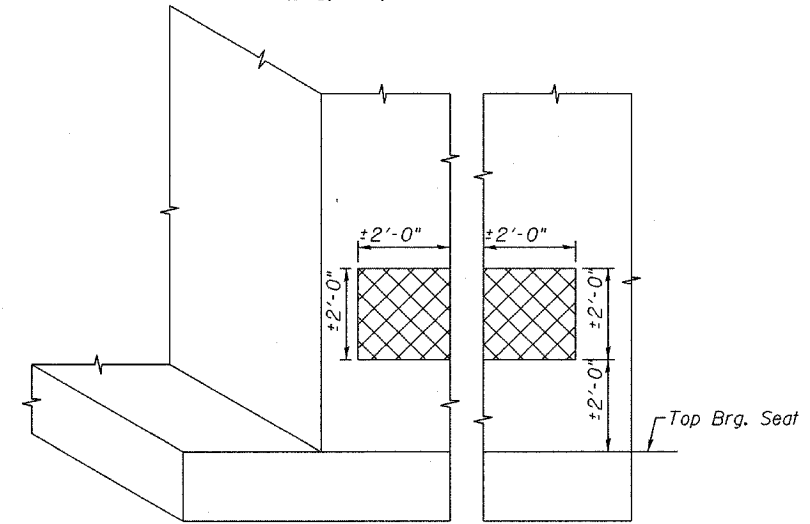

W. END ABUT. BK. WALL **W. WING WALL**
N. ABUTMENT - CORNER ELEV.
S.N. 101-0030

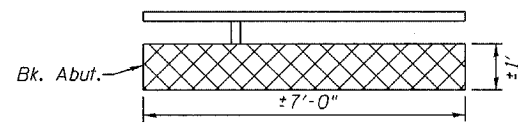

E. PARAPET WALL - NO. ABUT.
S.N. 101-0030
(LOOKING EAST)

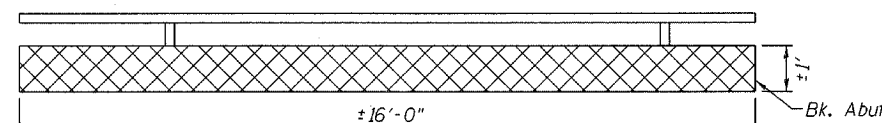

E. PARAPET WALL - SO. ABUT.
S.N. 101-0029
(LOOKING EAST)

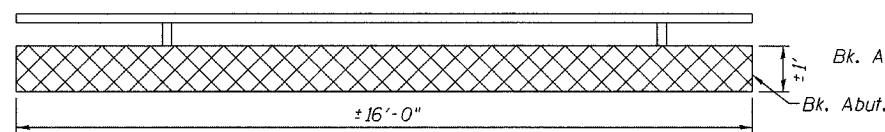

W. PARAPET WALL - NO. ABUT.
S.N. 101-0030
(LOOKING WEST)

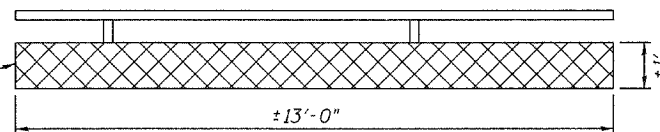

W. PARAPET WALL - SO. ABUT.
S.N. 101-0029
(LOOKING WEST)

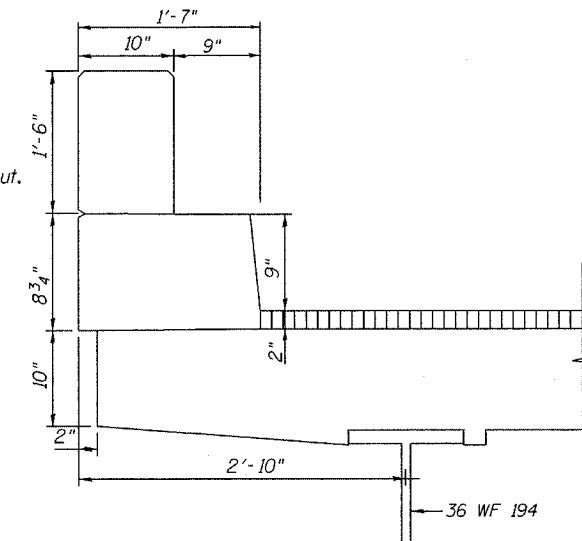

TYPICAL SEC. THRU PARAPET

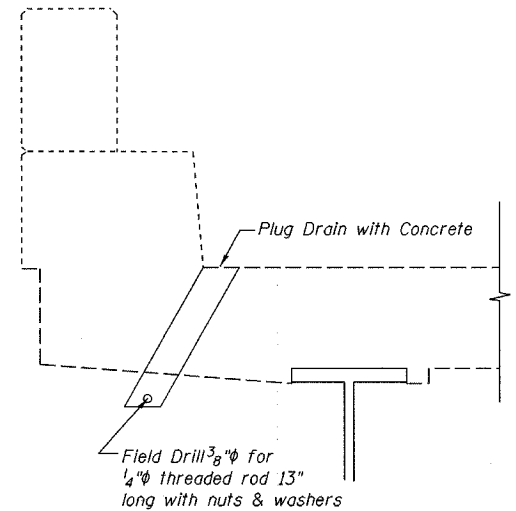

**DRAIN ELIMINATION
DETAIL**

(192 Ea. Required)

BILL OF MATERIAL

ITEM	UNIT	TOTAL
Formed Concrete Repair (Depth equal to or Less than 5")	Sq. Ft.	93

DESIGNED	SB, DP
CHECKED	SB
DRAWN	BH, BS
CHECKED	SB

 Formed Conc. Rep. <5"

CONCRETE REPAIR DETAILS
F.A.P. Route 303 &
FAP 738 (IL 251) OVER Railroad
SECTION (5VB, 5HB, 1-2HB)M
WINNEBAGO COUNTY
SN 101-0029 & 101-0030