

STATE OF ILLINOIS
DEPARTMENT OF TRANSPORTATION

ROUTE NO.	SECTION	COUNTY	SHEETS	SHEET	SHEET NO. <u>9</u>
	*	Winnebago	36	26	<u>9</u> SHEETS
FED. ROAD DIST. NO. 7	ILLINOIS	FED. AID PROJECT			

* (5VB, 5HB, 1-2HB)M CONTRACT #64A88

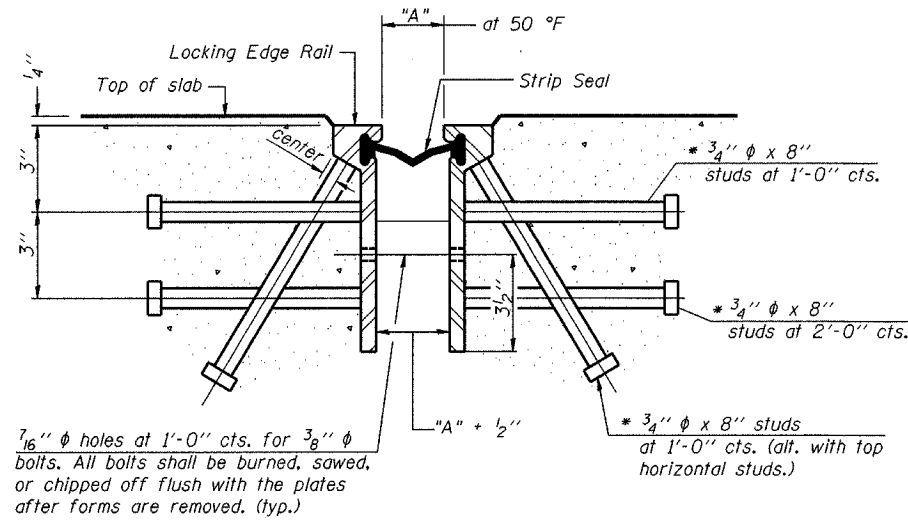

Required Strip Seal rated movement	"A"
1"	1 1/8"
2"	1 3/4"

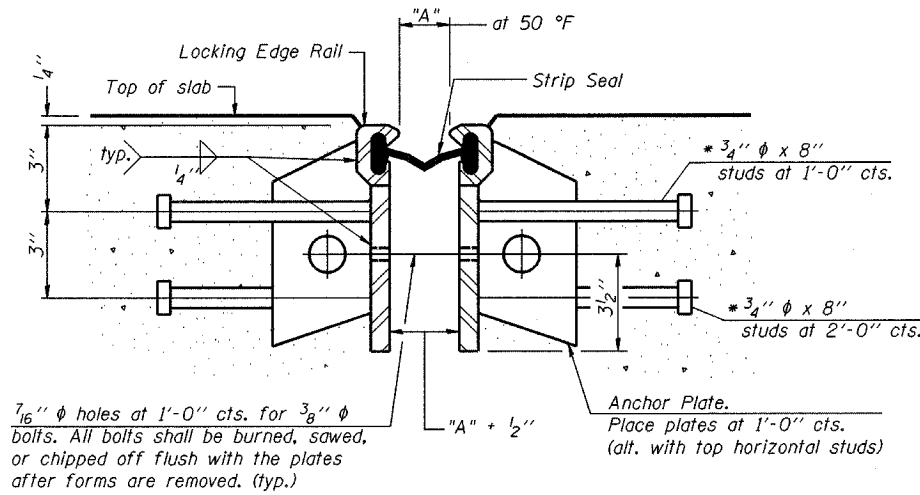

SECTION THRU ROLLED RAIL EXP. JOINT

SECTION THRU WELDED RAIL EXP. JOINT

GENERAL NOTES

The strip seal shall be made continuous and shall have a minimum thickness of 1/4". The configuration of the strip seal shall match the configuration of the Locking Edge Rails.

The height and thickness of the Locking Edge Rails shown are minimum dimensions. The actual configuration of the Locking Edge Rails and matching strip seal may vary from manufacturer to manufacturer. Flanged edge rails will not be allowed.

Locking Edge Rails may be spliced at slope discontinuities and stage construction joints.

The manufacturer's recommended installation methods shall be followed.

The joint opening and deck dimensions detailed on the superstructure are based on a preformed joint seal. If the contractor elects to use the alternate strip seal joint, the opening and deck dimensions shall be modified according to the dimensions detailed on this sheet. Required modifications shall be made at no additional cost to the State.

* Granular or solid flux filled headed studs conforming to Article 1006.32 of the Std. Specs., automatically end welded.

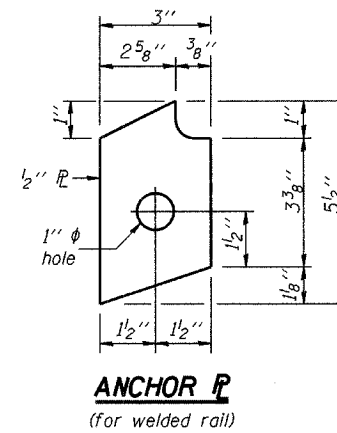
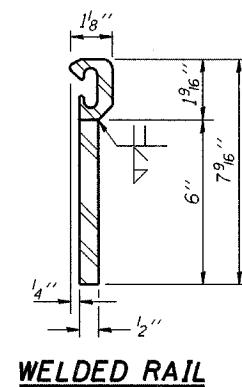
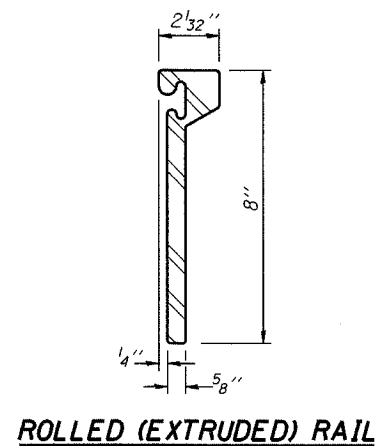

LOCKING EDGE RAILS

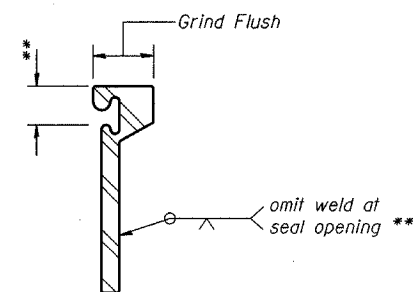

LOCKING EDGE RAIL SPLICE

The inside of the locking edge rail groove shall be free of weld residue.

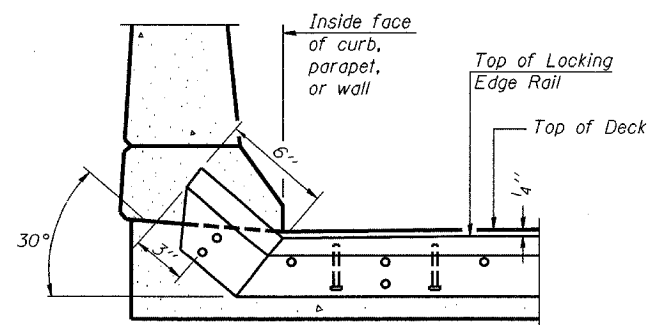

AT CURB, PARAPET, OR WALL

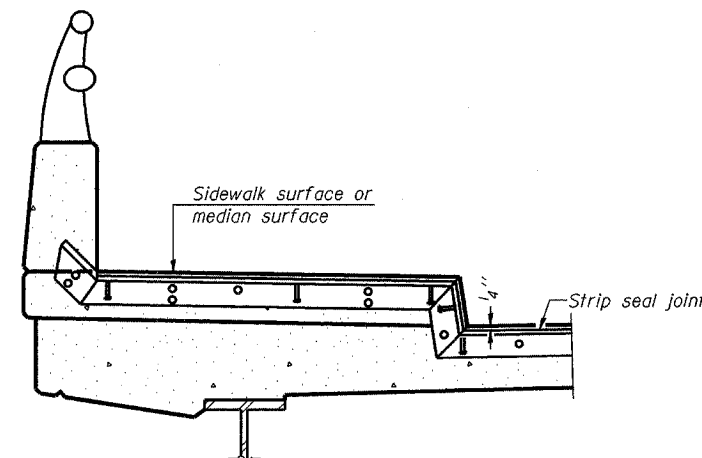

AT SIDEWALK OR MEDIAN*

* Shorter plates with a single row of studs at 12" centers may be necessary on medians which are shallower than 9". See manufacturer's recommendation.

TYPICAL END TREATMENTS

DESIGNED	SB, DP
CHECKED	SB
DRAWN	BH, BS
CHECKED	SB

EJ-BJS

10-22-04

**BRIDGE JOINT SYSTEM - EXPANSION
(ALTERNATE-STRIP SEAL)
F.A.P. Route 303 & F.A.P. Route 738
(IL 251) OVER Rockton Road
SECTION (5VB, 5HB, 1-2HB)M
WINNEBAGO COUNTY
SN 101-0031 & 101-0032**

(Sheet 2 of 2)