

F.A. RTE.	SECTION	COUNTY	TOTAL SHEETS	SHEET NO.
74	(72-7)R-3	PEORIA	1360	42
STA.		TO STA.		
FED. ROAD DIST. NO.		ILLINOIS	FED. AID PROJECT	

LEGEND:

- (52A) PR TOPSOIL, FURNISH AND PLACE, 100mm
- (54) PR POROUS GRANULAR EMBANKMENT
- (55) PR GEOTECHNICAL FABRIC FOR GROUND STABILIZATION
- (60) PR AGGREGATE SUB-BASE, 300 mm
- (61A) PR BITUMINOUS CONCRETE BINDER COURSE SUPERPAVE IL-19.0L (LOW ESAL), 100 mm
- (71D) PR PORTLAND CEMENT CONCRETE PAVEMENT, 250 mm (JOINTED)
- (79) PR AGGREGATE SHOULDERS, TYPE B
- (81A) PR PORTLAND CEMENT CONCRETE SHOULDERS 250 mm
- (82) PR RETAINING WALL
- (83) PR NOISE BARRIER
- (86A) PR PIPE UNDERDRAINS 100 mm
- (88) PR CONCRETE GUTTER, TYPE A (MODIFIED)
- (92A) PR CONCRETE BARRIER, DOUBLE FACE
- (92B) PR CONCRETE BARRIER, SINGLE FACE
- (96A) PR LONGITUDINAL CONSTRUCTION JOINT

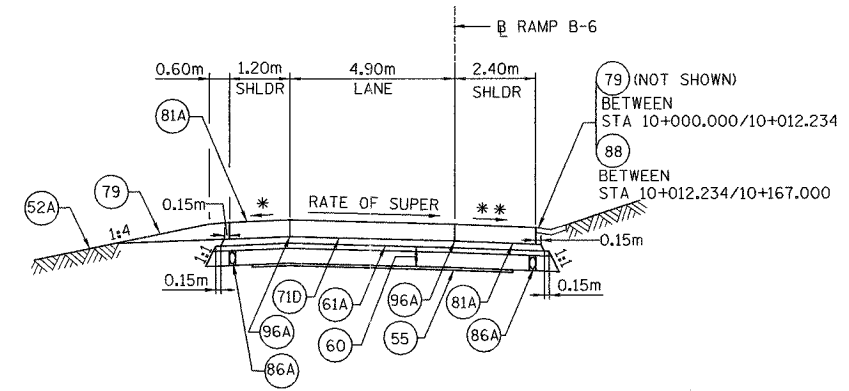

TYPICAL SECTION 1; RAMP B-6
 SUPERELEVATED SECTION
 STA. 10+048.052 TO STA. 10+167.000

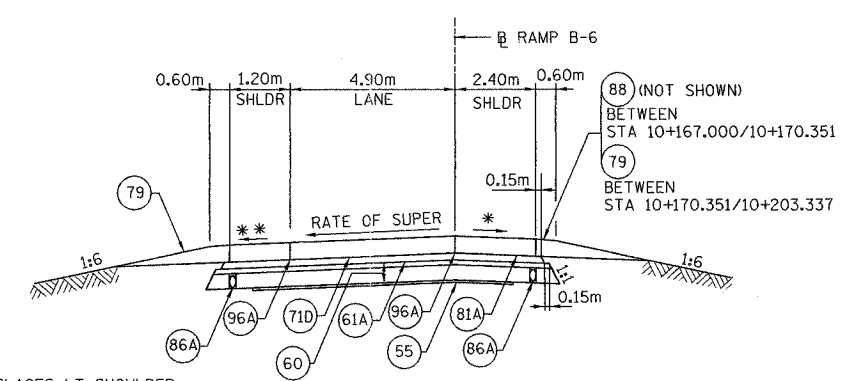

GORE REPLACES LT SHOULDER
 BETWEEN STA 10+182.578 TO STA 10+203.454
 TYPICAL SECTIONS BEYOND
 STA 10+203.337 ARE ON B-4 TYPICAL SECTIONS 2 & 3.

TYPICAL SECTION 2; RAMP B-6
 SUPERELEVATED SECTION
 STA. 10+167.000 TO STA. 10+203.337

* 4% OR 8% MINUS THE RATE OF SUPER, WHICHEVER IS MINIMUM
 ** 4% MIN. OR RATE OF SUPER, WHICHEVER IS GREATER.



REVISIONS	
NAME	DATE

ILLINOIS DEPARTMENT OF TRANSPORTATION
 TYPICAL SECTIONS
 FAI ROUTE 74 (I-74) (WB)
 PROPOSED RAMP B-6
 DRAWN BY CADD
 CHECKED BY KJW
 DATE 11/12/04