

D:\projects\74\74-101-5540.dgn 4/25/2005 11:34:41 AM

F.A.I. RTE.	SECTION	COUNTY	TOTAL SHEETS	SHEET NO.
74	*	TAZEWELL	1366	61
STA. TO STA.		FED. ROAD DIST. NO. ILLINOIS FED. AID PROJECT		
		* (90-10R-2; 90(13,14,14-10R-1		

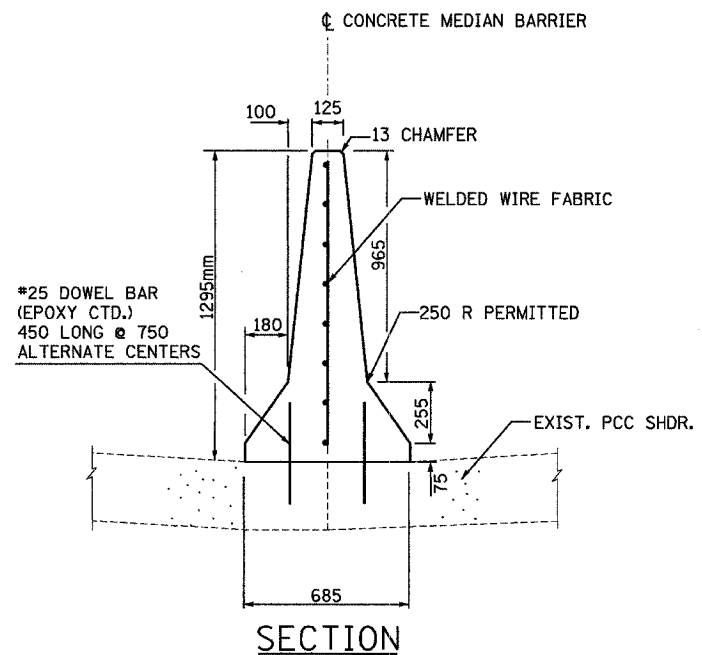
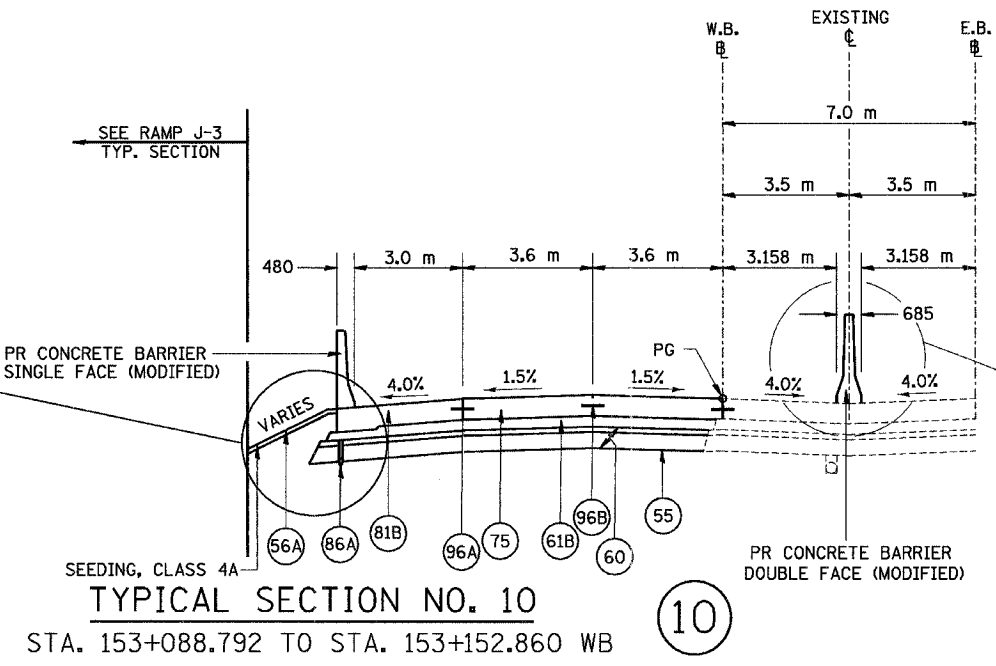
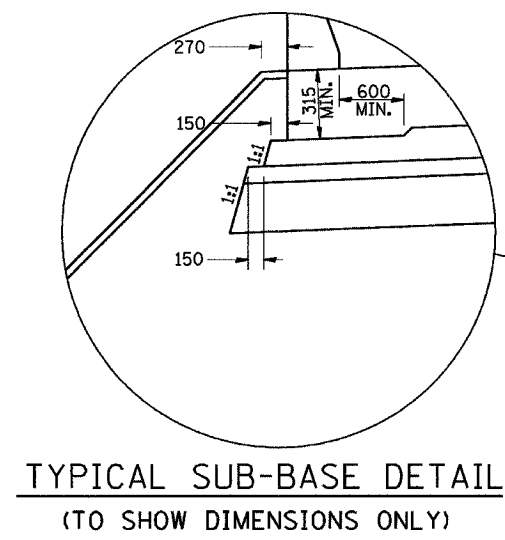

TYPICAL CONCRETE BARRIER, DOUBLE FACE (MODIFIED). SEE I-74 STD. 637001-174.

THE FURNISHING AND PLACING OF WELDED WIRE FABRIC AND DRILLED AND GROUTED DOWEL BARS SHALL BE INCLUDED IN THE COST OF THE CONCRETE BARRIER.

SEE LIGHTING PLANS FOR CONDUIT LOCATION.

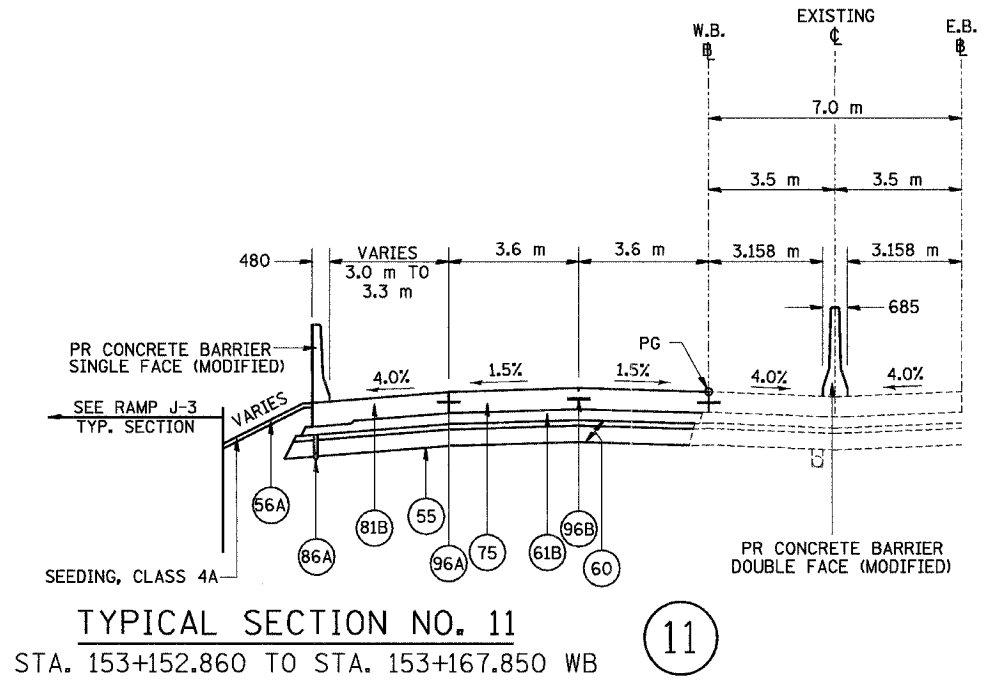

NOTES:

SHOULDERS ADJACENT TO THE HIGH SIDE OF SUPERELEVATED PAVEMENT SHALL BE 4% OR 8% MINUS THE RATE OF SUPER, WHICHEVER IS LESS. ADJACENT TO THE LOW SIDE OF SUPERELEVATED PAVEMENT SHOULDERS SHALL HAVE A SLOPE OF 4% OR THE RATE OF SUPER, WHICHEVER IS GREATER.

ALL DIMENSIONS ARE IN MILLIMETERS (mm) UNLESS OTHERWISE STATED.

60 IS SHOWN IN TWO LAYERS TO DENOTE THE TWO GRADATIONS THAT MAKE UP THIS PAY ITEM.

1 ADDED NOTES

LEGEND			
55	PR GEOTECHNICAL FABRIC FOR GROUND STABILIZATION	89K	PR COMB. CONCRETE C&G, TYPE B-15.45
56A	PR FURNISH AND PLACE TOPSOIL, 100 MM	96A	PR LONGITUDINAL CONSTRUCTION JOINT (TYPICAL)
60	PR AGGREGATE SUB-BASE, 300 MM	96B	PR SAWED LONGITUDINAL JOINT (TYPICAL)
61A	PR BITUMINOUS CONCRETE BINDER COURSE, SUPERPAVE, IL-19.0L (LOW ESAL), 100MM		
61B	PR BITUMINOUS CONCRETE BINDER COURSE, SUPERPAVE, IL-19.0L (LOW ESAL), 150MM		
71D	PR PORTLAND CEMENT CONCRETE PAVEMENT 250MM (JOINTED)		
75	PR CONTINUOUSLY REINFORCED PORTLAND CEMENT CONCRETE PAVEMENT, 290 MM		
79	PR AGGREGATE SHOULDERS, TYPE B		
81A	PR PORTLAND CEMENT CONCRETE SHOULDERS 250 MM		
81B	PR PORTLAND CEMENT CONCRETE SHOULDERS, 290 MM		
82	PR RETAINING WALL (SEE WALL PLANS)		
86A	PR PIPE UNDERDRAINS, 100 MM		
86B	PR PIPE UNDERDRAINS, 150 MM		
88	PR CONCRETE GUTTER, TYPE A (MODIFIED)		
89B	PR COMB. CONCRETE C&G, TYPE B-15.60		



REVISIONS	
NAME	DATE
1	MAY 27 2005

ILLINOIS DEPARTMENT OF TRANSPORTATION  
FAI ROUTE 74 (I-74)  
PROPOSED TYPICAL SECTIONS  
FAI ROUTE 74 (I-74) (WB)  
NUMBERS 10 & 11

DATE 12-20-04

DRAWN BY DER  
CHECKED BY MLB