

F.A. RTE.	SECTION	COUNTY	TOTAL SHEETS	SHEET NO.
			74	32
STA.		TO STA.		
FED. ROAD DIST. NO.	ILLINOIS	FED. AID PROJECT		
• 10ZIR5-1;IV,TIR5-2;SIR5-4I				

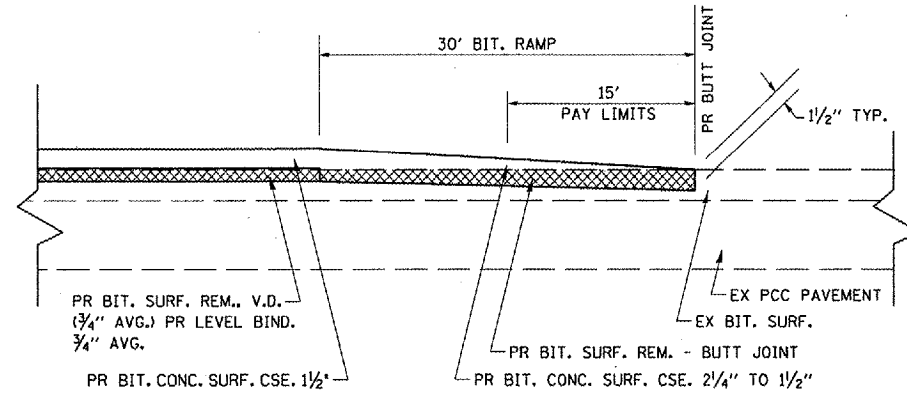

BIT. RAMP DETAIL

PART B

STA 38+00.00 TO STA 38+30.00
 STA 201+60.00 TO STA 201+90.00 - PR BUTT JOINT
 AT RAILROAD CROSSING
 STA 202+00.00 TO STA 202+30.00 - PR BUTT JOINT
 AT RAILROAD CROSSING

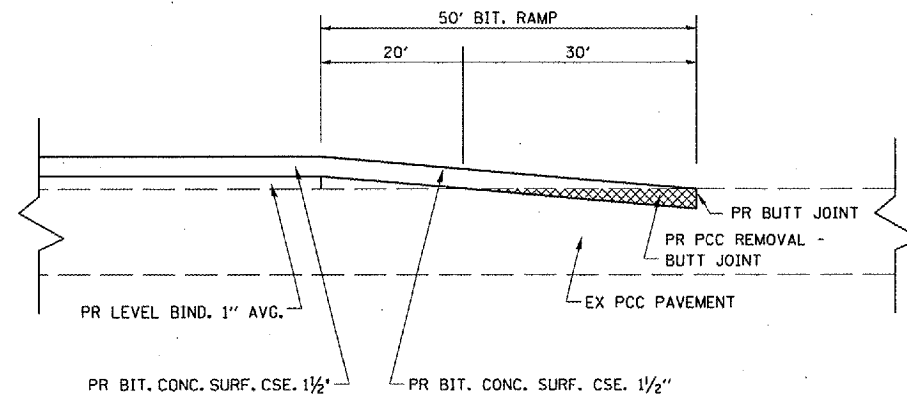

BIT. RAMP DETAIL

PART A

STA 441+00.00 TO STA 441+50.00
 STA 451+50.00 TO STA 452+00.00

REVISIONS	
NAME	DATE

ILLINOIS DEPARTMENT OF TRANSPORTATION

BUTT JOINT DETAILS

SCALE: VERT. _____
 HORIZ. _____

DATE _____ DRAWN BY _____
 CHECKED BY _____

PLT DATE = 2/29/2005
 FILE NAME = I:\projects\72405\as\as11.dgn
 PLOT SCALE = 43.375' / 1" IN.
 USER NAME = woodrj