

F.A.P. RTE.	SECTION	COUNTY	TOTAL SHEETS	SHEET NO.
325	*	MONTGOMERY	39	34
STA.		TO STA.		
FED. ROAD DIST. NO.		ILLINOIS FED. AID PROJECT		

• 21RS-4; 24RS-7
CONTRACT NO. 72444

LOCATION
STA. 4 + 015.860 TO STA. 4 + 025.000
STA. 7 + 327.836 TO STA. 7 + 341.552

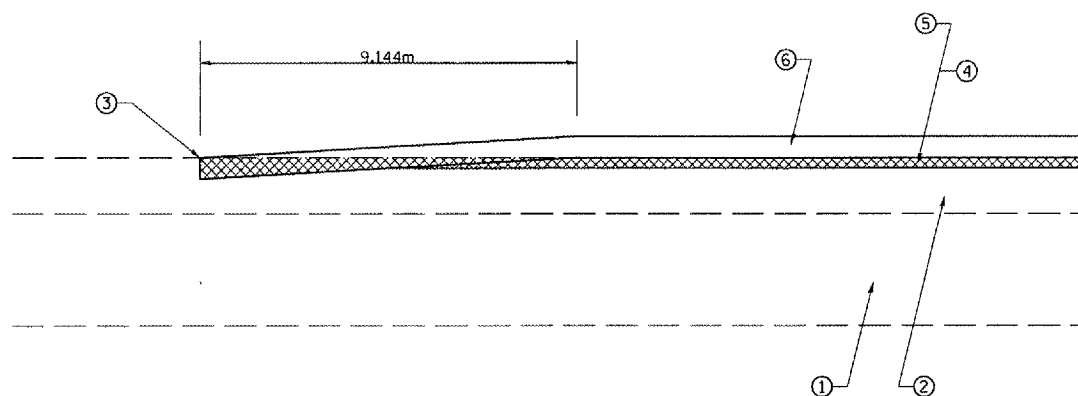

LEGEND

- ① EXISTING PCC PAVEMENT (203mm -152mm-203mm)
- ② EXISTING BITUMINOUS OVERLAY -
- ③ PROP. SAW CUT - 38mm MINIMUM
- ④ PROP. BITUMINOUS SURFACE REMOVAL - VAR. DEPTH
- ⑤ PROP. LEVELING BINDER (MACH. METHOD), SUPERPAVE, IL-9.5, N70 - 19mm
- ⑥ PROP. BIT. CONC. SURF. CSE., SUPERPAVE, MIX D, N50 - 38mm

LOCATION
STA. 7 + 342.000

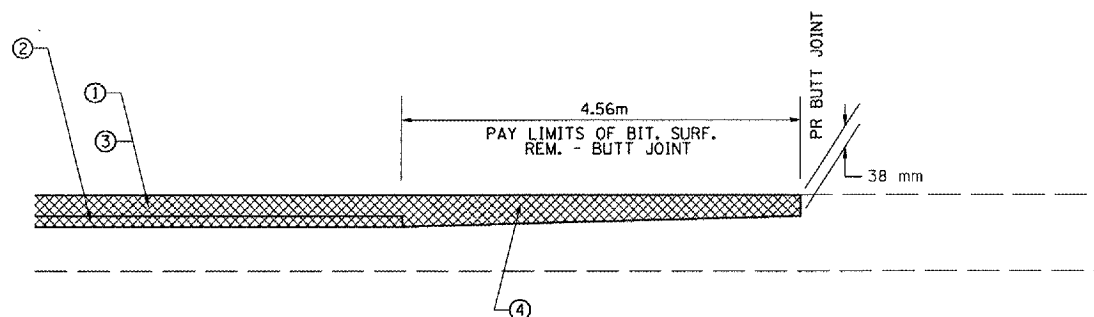

LEGEND

- ① PR BITUMINOUS SURFACE REMOVAL, 60 mm
- ② PR LEVEL. BINDER, 19 mm AVG.
- ③ PR BITUMINOUS CONCRETE SURF. CSE, 38 mm
- ④ PR BITUMINOUS SURF. REMOVAL - BUTT JOINT
PR BITUMINOUS CONCRETE SURF. CSE. (57 mm TO 38 mm)

REVISIONS	
NAME	DATE

ILLINOIS DEPARTMENT OF TRANSPORTATION

BUTT JOINT DETAILS

DRAWN BY
CHECKED BY
DATE