

WEST ABUTMENT ELEVATION
Looking West
Not To Scale

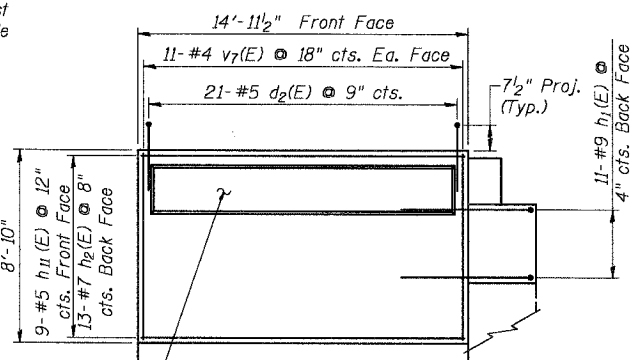

SOUTHWEST WING WALL ELEVATION
Not To Scale

LEGEND

Indicates Concrete Removal Area

Indicates Epoxy Crack Sealing

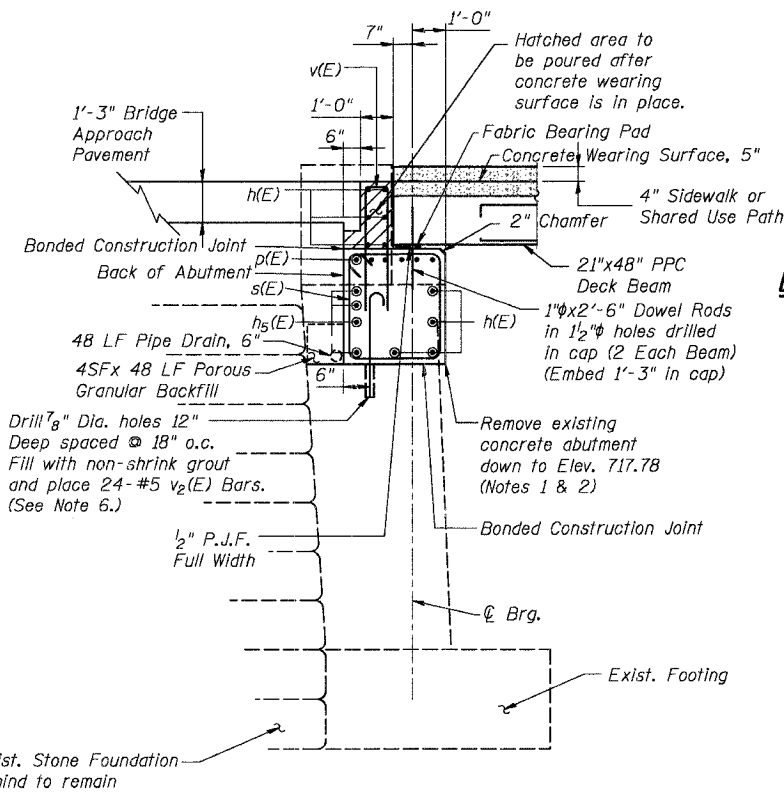

SECTION THRU ABUTMENT
(Looking North)
Not To Scale

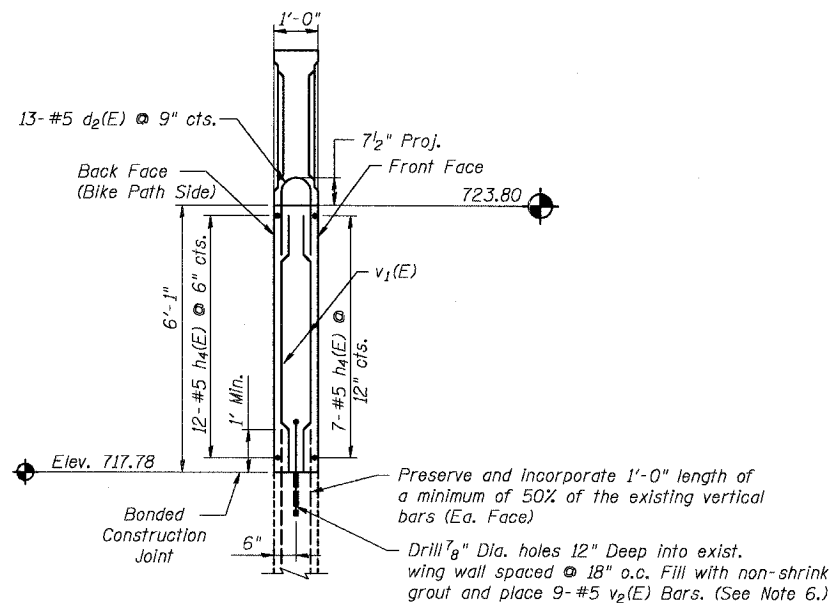

SECTION B-B
Not To Scale
(See S-10)

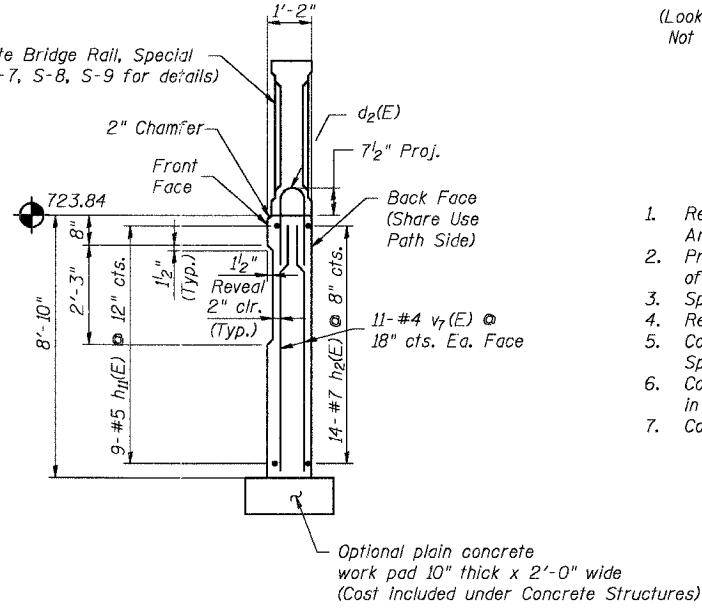

SECTION A-A
Not To Scale
(See S-10)

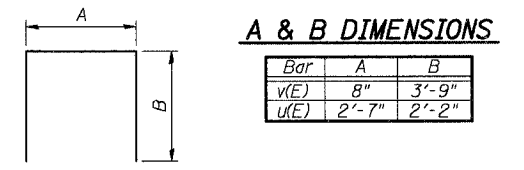

BARS v(E), u(E)

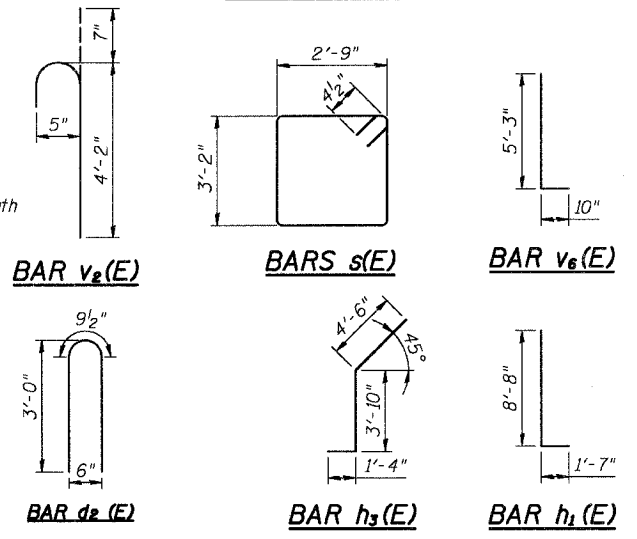

BAR v2(E)

BARS s(E)

BAR v6(E)

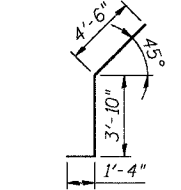

BAR h3(E)

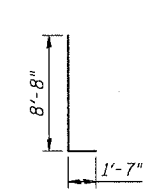

BAR h1(E)

- GENERAL NOTES**
1. Removal of existing concrete shall conform to Article 501.03 of the Standard Specifications.
 2. Preserve and incorporate 1'-0" length of a minimum of 50% of existing vertical reinforcement in removal area.
 3. Space reinforcement in abutment seat to miss anchor bolts.
 4. Reinforcement Bar Bending dimensions are out to out.
 5. Coordinate placement of d2(E) Bars with Concrete Bridge Rail, Special details on sheets S-7, S-8, and S-9.
 6. Cost for Drilling and Grouting v2(E) Bars shall be included in Reinforcement Bars, Epoxy Coated.
 7. Cost for Reveal shall be included in Concrete Structures.

BILL OF MATERIAL

Bar	No.	Size	Length (FT)	Shape
d2(E)	42	# 5	6'-3"	
h(E)	20	# 5	25'-0"	
h1(E)	11	# 9	10'-3"	
h2(E)	14	# 7	14'-8"	
h3(E)	7	# 8	9'-10"	
h4(E)	19	# 5	11'-2"	
h5(E)	8	# 7	25'-8"	
h6(E)	9	# 5	14'-8"	
p(E)	12	# 7	25'-8"	
s(E)	49	# 5	12'-7"	
u(E)	8	# 5	6'-11"	
v(E)	49	# 4	8'-2"	
v1(E)	18	# 4	5'-9"	
v2(E)	33	# 5	4'-9"	
v3(E)	22	# 4	8'-6"	
Reinforcement Bars, Epoxy Coated		Pound	4,510	
Concrete Removal		Cu. Yds.	34	
Concrete Structures		Cu. Yds.	33.5	
Structure Excavation		Cu. Yds.	30	
Epoxy Crack Sealing		Foot	42	
Pipe Drain, 6"		Foot	48	
Porous Granular Backfill		Cu. Yds.	30	

Reinforcement Bars designated (E) shall be Epoxy Coated

DESIGNED	KMA
CHECKED	RGD
DRAWN	WJH
CHECKED	NRF

SMITH ENGINEERING CONSULTANTS, INC.
CITY ENGINEERS & ARCHITECTS
1300 W. MONROE ST., SUITE 200
CHICAGO, ILL. 60606
www.smitheng.com

REVISIONS	
NAME	DATE

ILLINOIS DEPARTMENT OF TRANSPORTATION

West Abutment Details
Main Street Over Fox River
"Public Waters"
Village of Carpentersville
Section 02-00059-00-BR
SN. 045-6150
Kane County

DATE 02-25-2005