

STATE OF ILLINOIS
DEPARTMENT OF TRANSPORTATION

ROUTE NO.	SECTION	COUNTY	LIST SHEETS	SHEET NO.	SHEET NO. -26
2758	*	LAKE	40	36	30 - SHEETS
FED. ROAD DIST. NO.	ILLINOIS	FED. AID PROJECT	CONTRACT 83790		
* 02-00025-00-BR					

BILL OF MATERIAL

ITEM	UNIT	TOTAL
Form Liner Textured Surface	SQ YD	123
Coating System for Concrete	SQ FT	4000

All exposed surface of the piers and the abutments shall be coated, with the exception of the top of caps.

CONCRETE COATING

LOCATION	TOTAL (SQ FT)
North Abutment	535
North Abutment Retaining Walls	88
South Abutment	325
South Abutment Retaining Walls	147
Piers	1278
Deck Fascia	921
Fascia Beams	706

With the exception of the fascia beams, the color of the concrete coating shall be Cloud 57BR - See Special Provisions

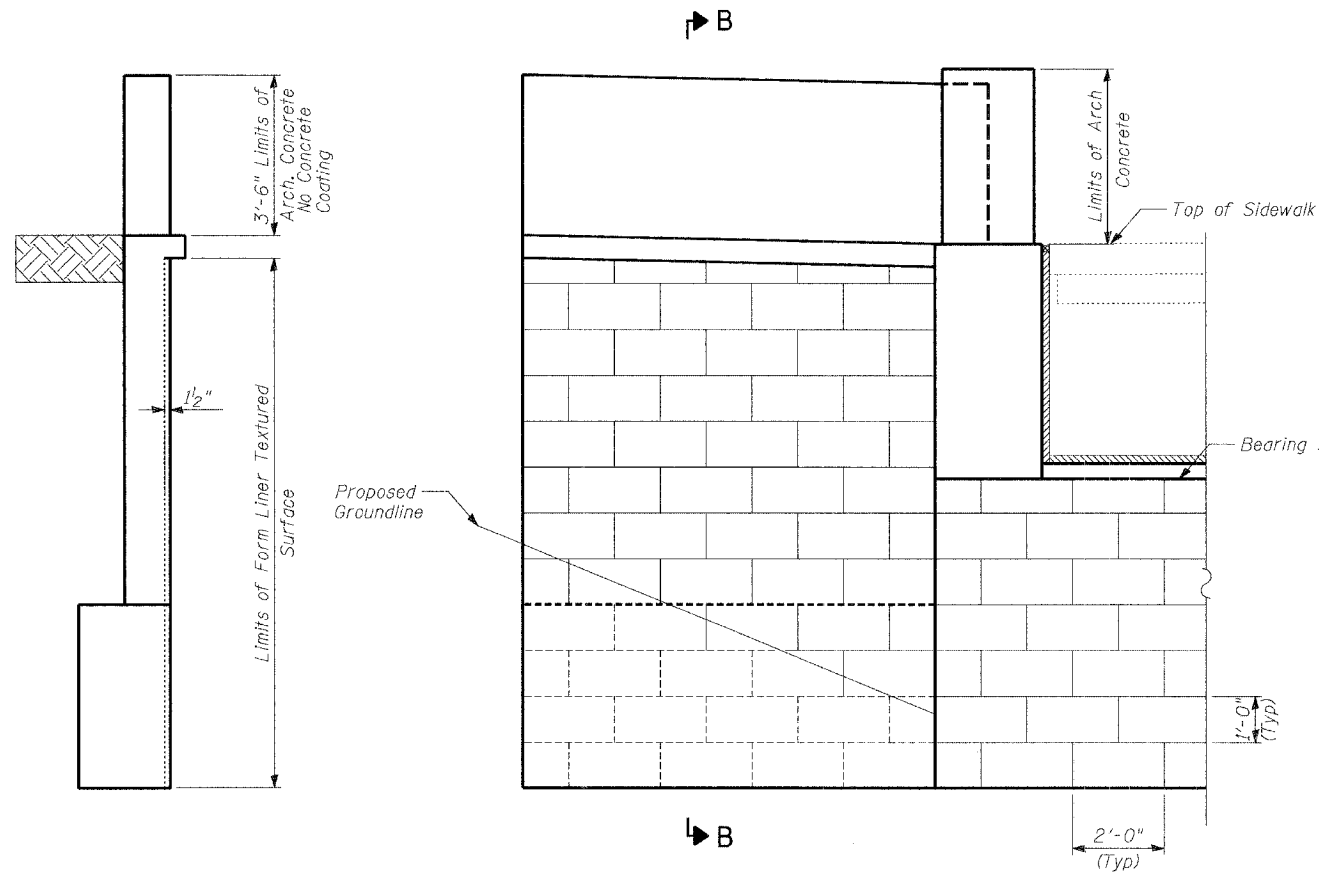

SECTION B-B

TYPICAL WINGWALL ELEVATION

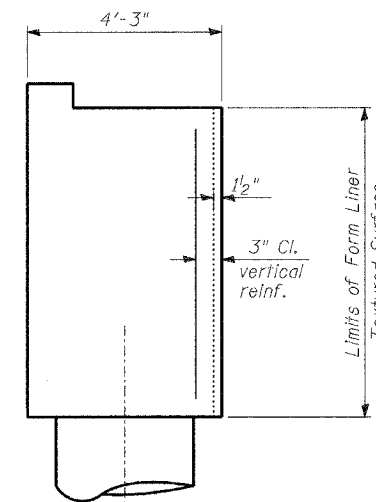

SECTION A-A

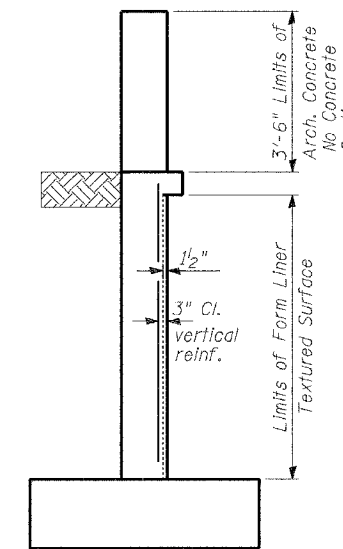

SECTION THRU RETAINING WALLS

Note: 3'-6" wall atop retaining wall not provided at South Abutment, East wall.

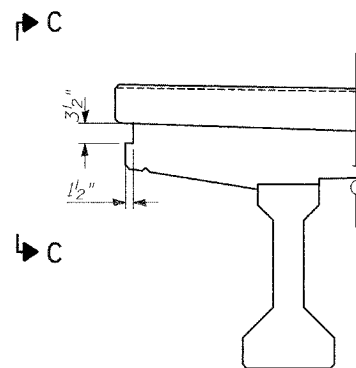

SECTION THRU DECK FASCIA

Note: Cost of Relief treatment to deck fascia as shown shall be included in the unit price of Concrete Superstructure.

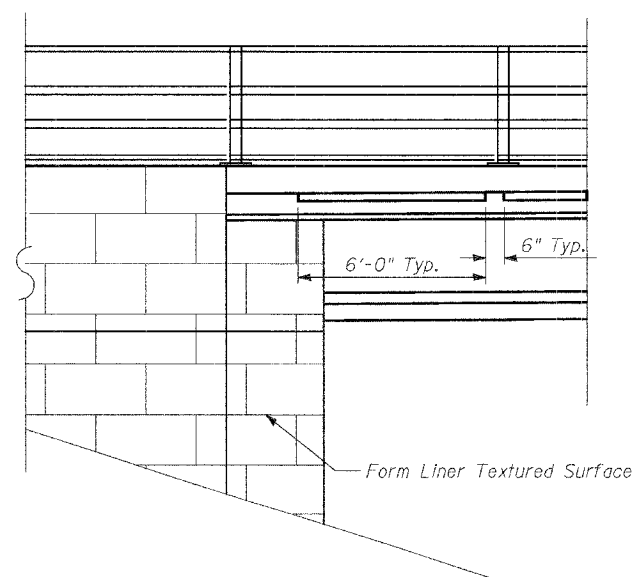

VIEW C-C

(Shown at South Abutment, East Face)

Cloud 57BR - See Special Provisions

RAL 6003 - See Special Provisions

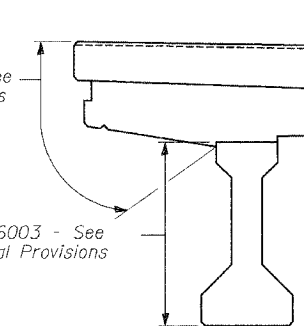

CONCRETE COATING OF FASCIA

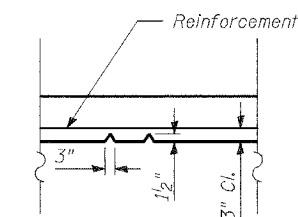

SECTION D-D

Cost of architectural finish, as shown in "ELEVATION OF NORTH & SOUTH ABUTMENT RETAINING WALLS" shall be included in the unit price of Architectural Concrete.

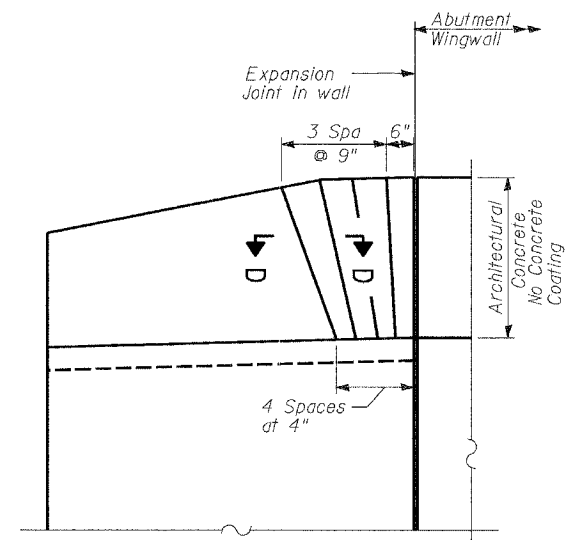

ELEVATION OF NORTH & SOUTH ABUTMENT RETAINING WALLS

(Above detail does not apply at South Abutment, East wall)

ARCHITECTURAL DETAILS

MOFFETT ROAD OVER
DRAINAGE RAVINE
FAU 2758
LAKE COUNTY
S.N. 049-6803

TYLIN INTERNATIONAL

DESIGNED	- SP
CHECKED	- PF
DRAWN	- SP
CHECKED	- PF

DATE: 02-23-2005