

F.A.U. RTE.	SECTION	COUNTY	TOTAL SHEETS	SHEET NO.
2758	02-00025-00 BR	LAKE	40	1
FED. ROAD DIST. NO.		ILLINOIS	FED. AID PROJECT	
CONTRACT NO. 83790				

INDEX OF SHEETS

FOR INDEX OF SHEETS, SEE SHEET NO. 2

PROJECT LOCATED IN VILLAGE OF LAKE BLUFF

DESIGN DESIGNATION

MOFFETT ROAD	ADT (2003)	POSTED SPEED	DESIGN SPEED
	1700	25 MPH	25 MPH
	ADT (2030)		
	3000		

PROPOSED IMPROVEMENT

THE PROJECT INVOLVES THE RECONSTRUCTION OF SN 049-6801 MOFFETT ROAD BRIDGE

STATE OF ILLINOIS
DEPARTMENT OF TRANSPORTATION
DIVISION OF HIGHWAYS

PLANS FOR PROPOSED LOCAL AGENCY IMPROVEMENT

FAU ROUTE 2758 (MOFFETT ROAD)
OVER DRAINAGE RAVINE
VILLAGE OF LAKE BLUFF
SECTION 02-00025-00-BR
PROJECT NO.: BRM-8003 (182)
BRIDGE REPLACEMENT
LAKE COUNTY
JOB NO: C-91-079-02



LOCATION OF SECTION INDICATED THUS: - [Symbol] -

STATE OF ILLINOIS
DEPARTMENT OF TRANSPORTATION
DIVISION OF HIGHWAYS

APPROVED February 18, 20 05
Benj S. Zell
VILLAGE OF LAKE BLUFF

APPROVED February 24, 20 05
Donald A. Jakesch
BUREAU CHIEF OF LOCAL ROADS AND STREETS

APPROVED February 24, 20 05
Dina O'Keefe
DISTRICT ENGINEER

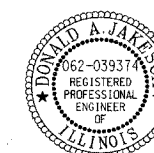

Signed Donald A. Jakesch
Donald A. Jakesch, P.E., Ill. Lic. No. 062-039374
Expires 11-30-2005
Date 02-11-05

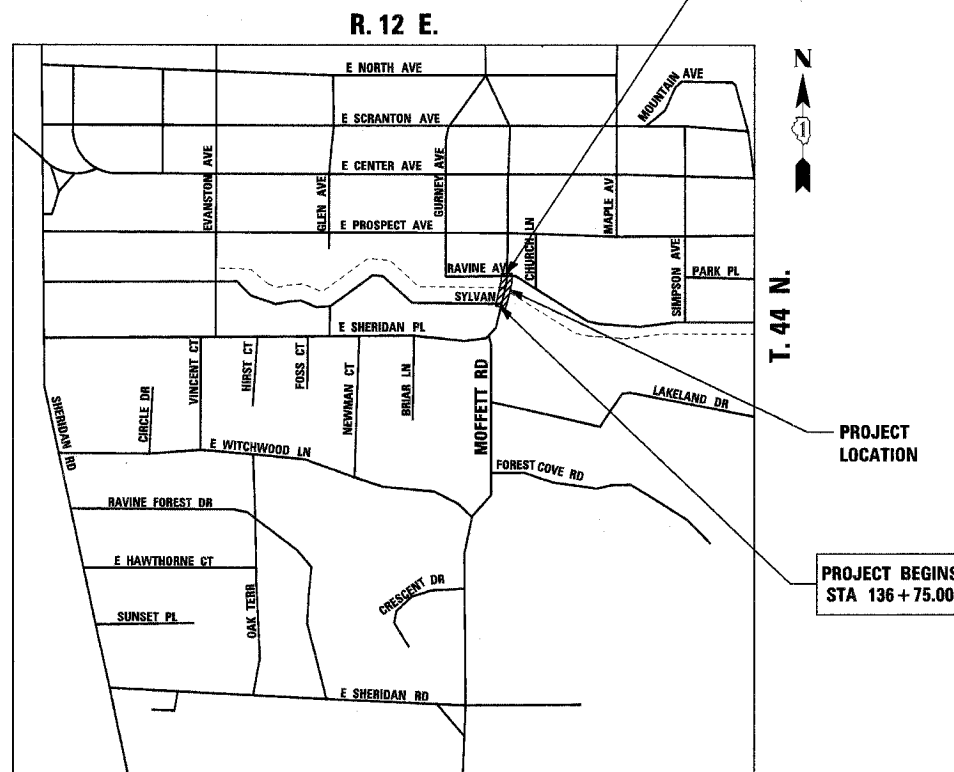

PROJECT ENDS
STA 139+20.00

T. 44 N.

PROJECT LOCATION

PROJECT BEGINS
STA 136+75.00

NOT TO SCALE
LAKE BLUFF TOWNSHIP
GROSS LENGTH OF PROJECT = 245 FT. = 0.05 MI.
NET LENGTH OF PROJECT = 245 FT. = 0.05 MI.

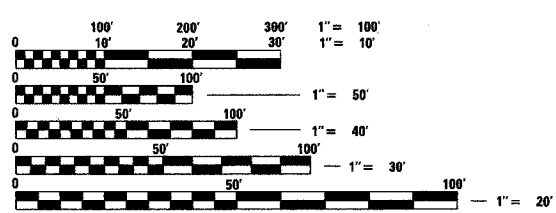

FULL SIZE PLANS HAVE BEEN PREPARED USING STANDARD ENGINEERING SCALES, REDUCED SIZED PLANS WILL NOT CONFORM TO STANDARD SCALES. IN MAKING MEASUREMENTS ON REDUCED PLANS, THE ABOVE SCALES MAY BE USED.

J.U.L.I.E.
JOINT UTILITY LOCATION INFORMATION FOR EXCAVATION
1-800-892-0123

CONTRACT NO. 83790

PREPARED BY: T.Y. LIN INTERNATIONAL, INC. DISTRICT ONE FEDERAL AID PROGRAM ENGINEER CHARLES F. RIDDLE (847) 705-4406

PRINTED BY THE AUTHORITY OF THE STATE OF ILLINOIS

SUMMARY OF QUANTITIES

CODE NO.	ITEM	UNIT	TOTAL QUANTITIES	H10 ROADWAY 1000-2A	H10 STRUCTURAL X081-2A	VILLAGE OF LAKE BLUFF
* 20100110	TREE REMOVAL 6 TO 15 UNITS	UNIT	73	73		
* 20100210	TREE REMOVAL > 15 UNITS	UNIT	42	42		
* 20101100	TREE TRUNK PROTECTION	EACH	9	9		
20200100	EARTH EXCAVATION	CU YD	712	712		
20700220	POROUS GRANULAR EMBANKMENT	CU YD	351		351	
20800150	TRENCH BACKFILL	CU YD	378	221		157
21101615	TOP SOIL, FURNISH AND PLACE, 4 INCH	SQ YD	325	325		
* 25001100	SEEDING, CLASS 3 (SPECIAL)	ACRE	0.1	0.1		
* 25000400	NITROGEN FERTILIZER NUTRIENT	LBS	7	7		
* 25000500	PHOSPHORUS FERTILIZER NUTRIENT	LBS	7	7		
* 25000600	POTASSIUM FERTILIZER NUTRIENT	LBS	7	7		
* 25100630	EROSION CONTROL BLANKET	SQ YD	243	243		
* 25200110	SODDING, SALT TOLERANT	SQ YD	82	82		
28100105	STONE RIP RAP, CLASS A3	SQ YD	410	410		
28100109	STONE RIP RAP, CLASS A5	SQ YD	542	542		
28200200	FILTER FABRIC	SQ YD	952	952		
31101200	SUB-BASE GRANULAR MATERIAL, TYPE B, 4 INCH	SQ YD	52	52		
40400705	AGGREGATE, SPECIAL	TON	4	4		
40600200	BITUMINOUS MATERIALS (PRIME COAT)	TON	0.2	0.2		
40800040	INCIDENTAL BITUMINOUS SURFACING	TON	2	2		
42001400	BRIDGE APPROACH PAVEMENT (SPECIAL)	SQ YD	202	202		
42001430	BRIDGE APPROACH PAVEMENT CONNECTOR (FLEXIBLE)	SQ YD	43	43		
42300300	PORTLAND CEMENT CONCRETE DRIVEWAY, 7-INCH	SQ YD	20	20		
42400200	PORTLAND CEMENT CONCRETE SIDEWALK, 5 INCH	SQ FT	107	107		
44000011	BITUMINOUS SURFACE REMOVAL, 4 INCH	SQ YD	329	329		
44000100	PAVEMENT REMOVAL	SQ YD	187	187		
44000500	COMBINATION CURB AND GUTTER REMOVAL	FT	176	176		
44000600	SIDEWALK REMOVAL	SQ FT	429	429		
44200120	PAVEMENT PATCHING, TYPE II, 10 INCH	SQ YD	70	70		
50100100	REMOVAL OF EXISTING STRUCTURES	EACH	1		1	
50104400	CONCRETE HEADWALL REMOVAL	EACH	2	2		
50200100	STRUCTURE EXCAVATION	CU YD	384		384	
50300100	FLOOR DRAINS	EACH	6		6	
50300255	CONCRETE SUPERSTRUCTURE	CU YD	195.1		195.1	
50300260	BRIDGE DECK GROOVING	SQ YD	300		300	
50300300	PROTECTIVE COAT	SQ YD	810	291	519	
50300310	ELASTOMERIC BEARING ASSEMBLY, TYPE I	EACH	12		12	
50400805	F&E PP CON I-BM 36 INCH	FOOT	662		662	
50500405	FURNISHING AND ERECTING STRUCTURAL STEEL	POUND	551		551	
50800105	REINFORCEMENT BARS	POUND	15140		15140	
50800205	REINFORCEMENT BARS, EPOXY COATED	POUND	60690		60690	
51500100	NAME PLATES	EACH	1		1	
59100100	GEOCOMPOSITE WALL DRAIN	SQ YD	71		71	

* - SPECIALTY ITEM

SUMMARY OF QUANTITIES

CODE NO.	ITEM	UNIT	TOTAL QUANTITIES	H10 ROADWAY 1000-2A	H10 STRUCTURAL X081-2A	VILLAGE OF LAKE BLUFF
60100060	CONCRETE HEADWALL FOR PIPE DRAINS	EACH	2		2	
60102005	PIPE DRAINS, 12-INCH, (SPECIAL)	FOOT	150	150		
60108200	PIPE UNDERDRAINS, 6 INCH, (SPECIAL)	FOOT	30		30	
60201105	CATCH BASINS, TYPE A, 4 FT DIAMETER, TYPE 11 FRAME AND GRATE	EACH	4	4		
60207605	CATCH BASINS, TYPE C, TYPE 8 GRATE	EACH	1	1		
60218400	MANHOLES, TYPE A, 4 FT DIAMETER, TYPE 1 FRAME, CLOSED LID	EACH	2	2		
60221000	MANHOLES, TYPE A, 5 FT DIAMETER, TYPE 1 FRAME, OPEN LID	EACH	1	1		
60228110	MANHOLES, SANITARY, 4 FT DIAMETER, TYPE 1 FRAME, CLOSED LID	EACH	1			1
60228120	MANHOLES, SANITARY, 5 FT DIAMETER, TYPE 1 FRAME, CLOSED LID	EACH	2			2
60500040	REMOVING MANHOLES	EACH	2	1		1
60500050	REMOVING CATCH BASINS	EACH	4	4		
60603800	COMBINATION CONCRETE CURB AND GUTTER TYPE B-6.12	FT	166	166		
67000400	ENGINEER'S FIELD OFFICE, TYPE A	CAL MO	7	7		
67100100	MOBILIZATION	L SUM	1	1		
* 70101800	TRAFFIC CONTROL AND PROTECTION, SPECIAL	L SUM	1	1		
* 72000100	SIGN PANEL - TYPE 1	SQ FT	16	16		
* 72400310	REMOVE SIGN PANEL - TYPE 1	SQ FT	9	9		
* 72900100	METAL POST, TYPE A	FT	50	50		
* 78005110	EPOXY PAVEMENT MARKING, LINE 4 INCH	FT	375	375		
* 78005130	EPOXY PAVEMENT MARKING, LINE 6 INCH	FT	322	322		
* 78005180	EPOXY PAVEMENT MARKING, LINE 24 INCH	FT	63	63		
* 78100100	RAISED REFLECTIVE PAVEMENT MARKER	EACH	4	4		
* 78100105	RAISED REFLECTIVE PAVEMENT MARKER (BRIDGE)	EACH	6	6		
550A0340	STORM SEWER, CLASS A, TYPE 2, 12 INCH	FT	114	114		
550A0380	STORM SEWER, CLASS A, TYPE 2, 18 INCH	FT	65	65		
* A2006416	QUERCUS ALBA (WHITE OAK), 2 INCH CALIPER, BALLED AND BURLAPPED	EACH	3	3		
* A2007116	QUERCUS ALBA (RED OAK), 2 INCH CALIPER, BALLED AND BURLAPPED	EACH	3	3		
X0323202	SANITARY SEWER, DUCTILE IRON, 16 INCH	FT	31			31
X0323204	SANITARY SEWER, DUCTILE IRON, 20 INCH	FT	175			175
X0323830	DRAINAGE SCUPPERS, DS-11	EACH	4		4	
X0504200	CONCRETE HEADWALL	EACH	2	2		
X4066414	BITUMINOUS CONCRETE SURFACE COURSE, SUPERPAVE, MIX C, N50	TON	38	38		
X4066614	BITUMINOUS CONCRETE BINDER COURSE, SUPERPAVE, IL-19.0, N50	TON	48	48		
XX001429	FORM LINER TEXTURED SURFACE	SQ YD	123			123
XX004647	ARCHITECTURAL CONCRETE	CU YD	9.7			9.7
XX005713	ORNAMENTAL RAILING	FOOT	230		230	
Z0002600	BAR SPLICERS	EACH	80		80	
Z0008236	DRILLED SHAFT IN SOIL, 36 INCH	FOOT	322		322	
Z0076600	TRAINEES	HOURS	500	500		
XX004223	PERIMETER EROSION BARRIER, MODIFIED	FT	657	657		
XX004224	COATING SYSTEM FOR CONCRETE	SQ FT	4000			4000
XX004225	CONCRETE STRUCTURES, SPECIAL	CU YD	161.6		161.6	

* - SPECIALTY ITEM

△ - Y080

REVISIONS	
NAME	DATE

ILLINOIS DEPARTMENT OF TRANSPORTATION
**MOFFETT ROAD BRIDGE
OVER DRAINAGE Ravine**

SUMMARY OF QUANTITIES
SCALE: NONE
DATE: 02-02-05
DRAWN BY: BK
CHECKED BY: DAJ

DETOUR SIGN SCHEDULE

SIGN	MUTCD DESIGNATION	SIZE	QUANTITY
	M4-9	30in X 24in	3
	M4-9L	30in X 24in	5
	M4-9R	30in X 24in	6
	M4-9L	30in X 24in	1
	SPECIAL	84 in X 24in	3
	W20-2	48in X 48in	3
	M3-1	24in X 12in	8
	M3-3	24in X 12in	7
	NONE	36in X 12in	21
	M4-8A	30in X 24in	3
	W20-3(0)	36in X 36in	4
	NONE	36in X 36in	2

NOTES:

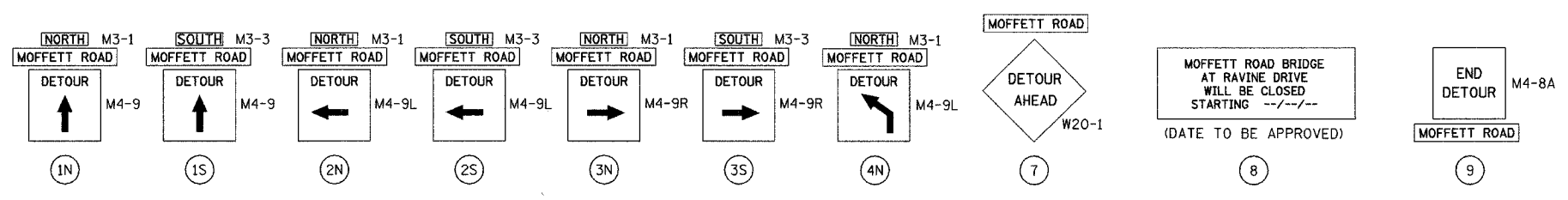
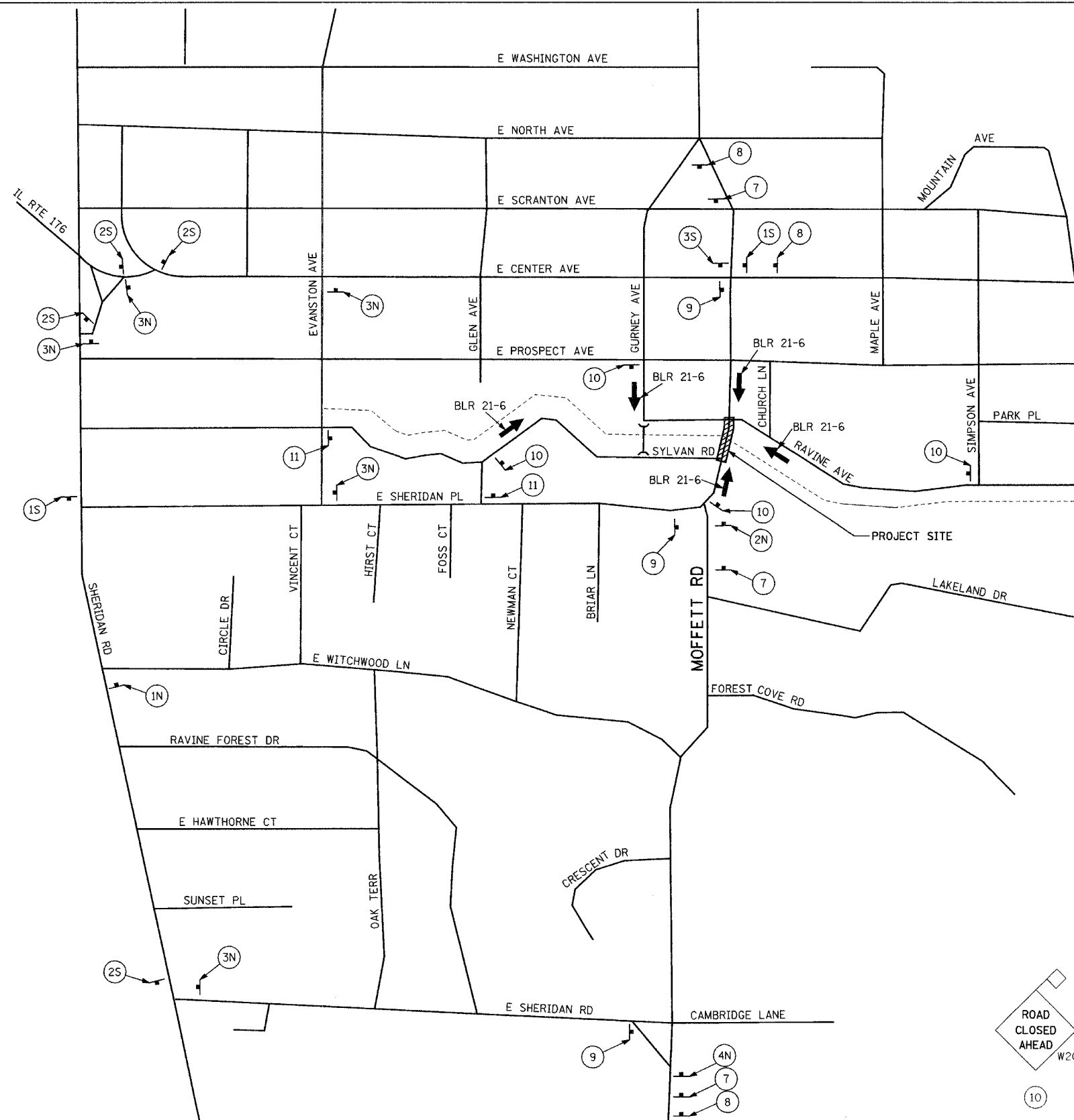
- ALL DETOUR SIGNS SHALL BE IN ORANGE COLOR BACKGROUND WITH BLACK LETTERS.
- FOLLOW LATEST MUTCD MANUAL AND IDOT STANDARDS FOR DETOUR SIGNS AND MAINTENANCE OF TRAFFIC SIGNS.
- THE COST OF THE DETOUR SIGNING SHALL BE INCLUDED IN THE COST OF TRAFFIC CONTROL AND PROTECTION, SPECIAL.
- SIDEWALK CLOSURE SIGNING SHALL BE PER STANDARD 701801, AND INCLUDED IN THE COST OF TRAFFIC CONTROL AND PROTECTION, SPECIAL.



REVISIONS		ILLINOIS DEPARTMENT OF TRANSPORTATION LAKE BLUFF	MOFFETT ROAD BRIDGE OVER DRAINAGE RAVINE MAINTENANCE OF TRAFFIC DETOUR PLAN
NAME	DATE		

SCALE: NONE
DATE: 02-02-05

DRAWN BY: BK
CHECKED BY: DAJ

DATE: _____ BY: _____
 REVISIONS: _____
 PLAN: _____
 PROFILE: _____
 NO. _____



DATE	
BY	
SURVEYED	
ALIGNMENT CHECKED	
GRADES CHECKED	
PLAN, NOTES, & MATHS CHECKED	
DATE	
NO.	

DATE	
BY	
SURVEYED	
GRADES CHECKED	
PLAN, NOTES, & MATHS CHECKED	
DATE	
NO.	

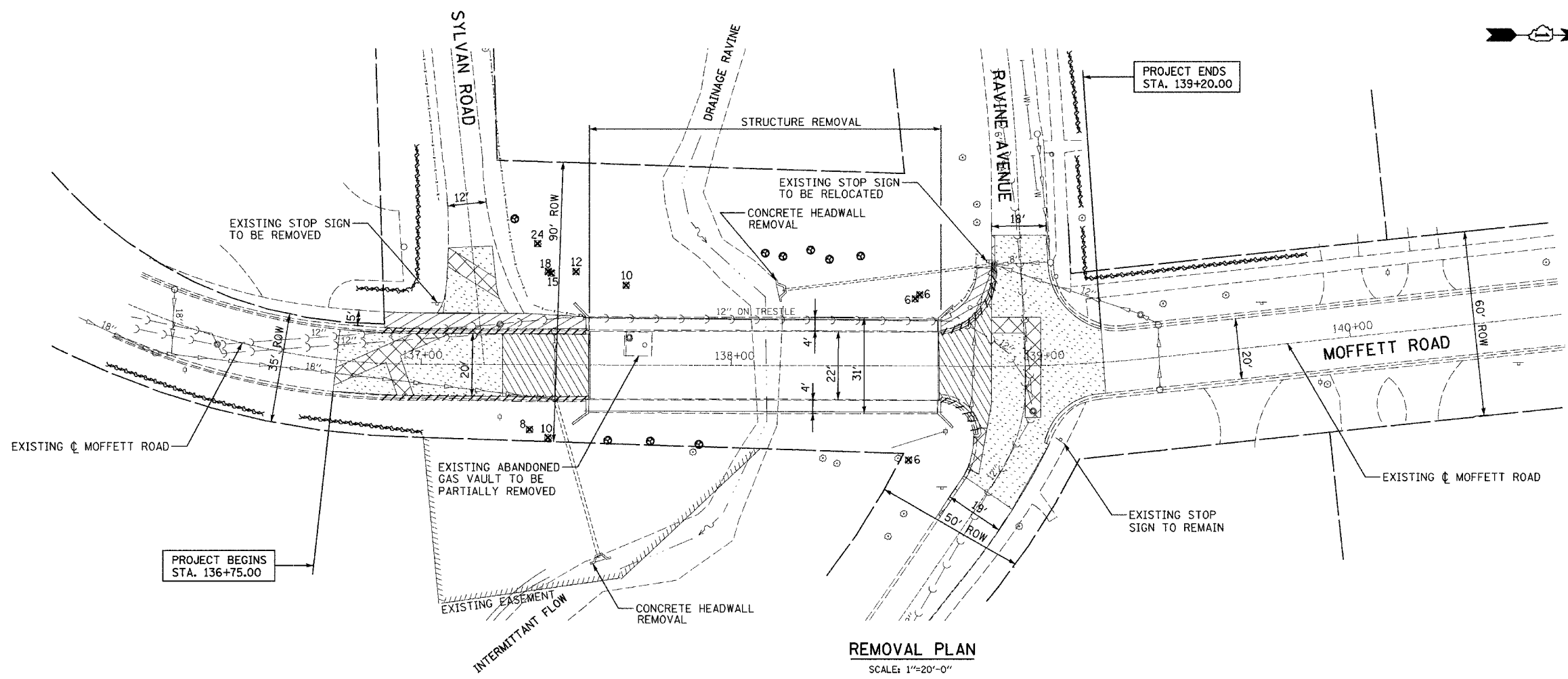

- LEGEND:**
- PAVEMENT REMOVAL
 - PAVEMENT REMOVAL AND PAVEMENT PATCHING, TYPE II, 10"
 - SIDEWALK REMOVAL
 - BITUMINOUS SURFACE REMOVAL, 4"
 - COMB CONC CURB & GUTTER REMOVAL
 - TREE PROTECTION
 - TREE REMOVAL (UNITS) (NO UNIT SHOWN = <6)

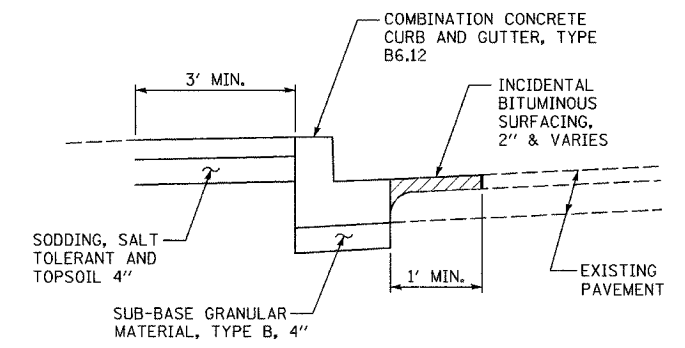
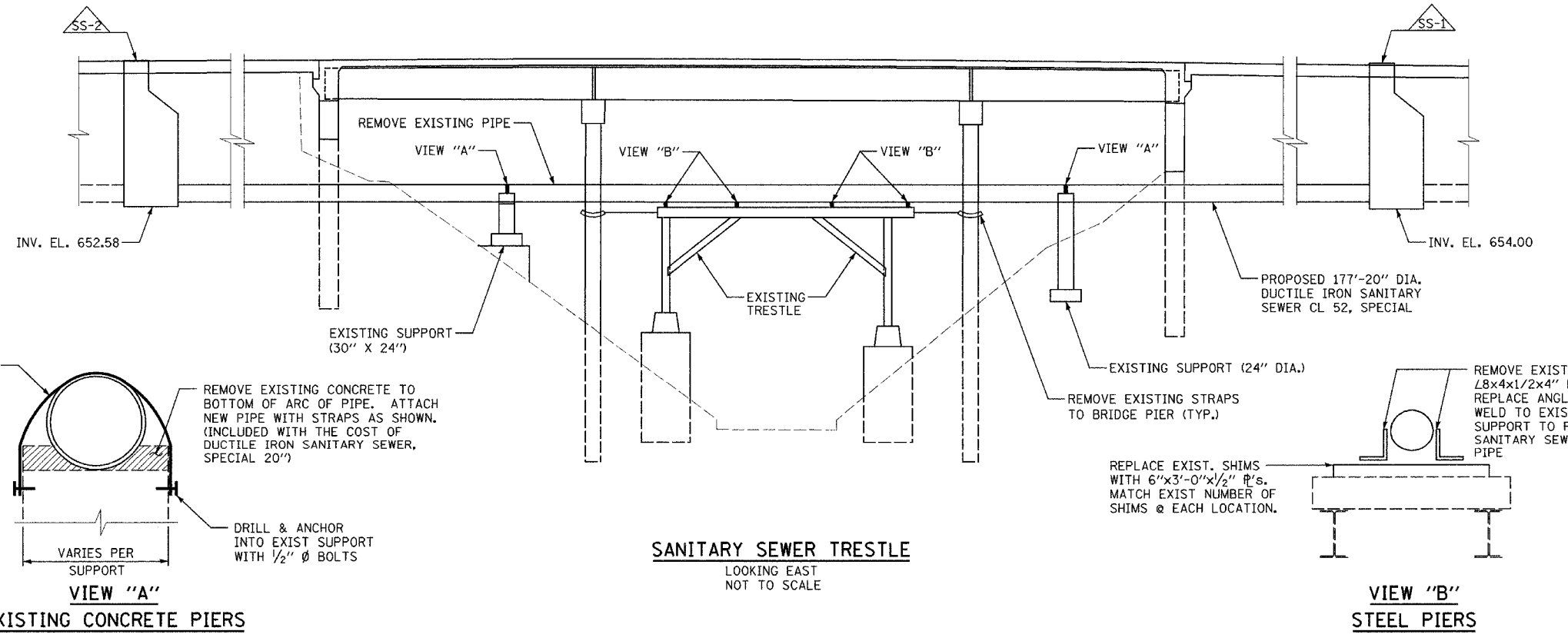
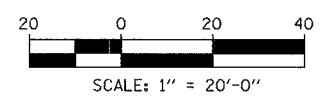

REVISIONS	
NAME	DATE

ILLINOIS DEPARTMENT OF TRANSPORTATION
MOFFETT ROAD BRIDGE OVER DRAINAGE RAVINE
 REMOVAL PLAN AND DETAILS

SCALE: AS SHOWN
 DATE: 02-02-05
 DRAWN BY: BK
 CHECKED BY: DAJ

DRAWN BY: BK
 CHECKED BY: DAJ
 DATE: 02-02-05

STRUCTURES BENCHMARK: SET SQUARE ON NE ABUTMENT /WINGWALL EL. 665.04

- 1 STA. 137+05, 37 FT LT
CB, T-C, 2 FT DIA.
T8G
RIM 663.21
INVERT 656.50
- 2 STA. 137+24, 25 FT LT
CB, T-A, 4 FT DIA.
T11 F&G
RIM 663.51
INVERT 656.10
- 3 STA. 136+95, 10 FT RT
CB, T-A, 4 FT DIA.
T11 F&G
RIM 663.24
INVERT 656.25
- 4 STA. 136+75, 4 FT RT
MH, T-A, 4 FT DIA.
T1FCL
RIM 663.38
INVERT 656.02
- 5 STA. 137+34, 24 FT LT
MH, T-A, 4 FT DIA.
T1FCL
RIM 664.17
SE INVERT 655.92
S INVERT 655.92
N INVERT 653.92
- 6 STA. 138+78, 32 FT RT
CB, T-A, 4 FT DIA.
T11 F&G
RIM 663.79
INVERT 659.16
- 7 STA. 138+83, 24 FT LT
CB, T-A, 4 FT DIA.
T11 F&G
RIM 663.96
INVERT 658.77
- 8 STA. 138+83, 33 FT LT
MH, T-A, 5 FT DIA.
T1FOL
RIM 664.16
N INVERT 660.61
NE INVERT 658.66
E INVERT 658.61
S INVERT 658.61
- SS-1 STA. 137+20, 13 FT LT
MH, SANITARY, T-A, 5 FT DIA.
T1FCL
RIM 663.62
S INVERT 654.00
SSE INVERT 654.00
- SS-2 STA. 138+95, 14.3 FT LT
MH, SANITARY, T-A, 5 FT DIA.
T1FCL
RIM 664.18
N,S & E INVERT 652.58
W INVERT (6") 652.60
- SS-3 STA. 138+97, 15 FT RT
MH, SANITARY, T-A, 4 FT DIA.
T1FCL
RIM 664.18
E&W INVERT 652.43

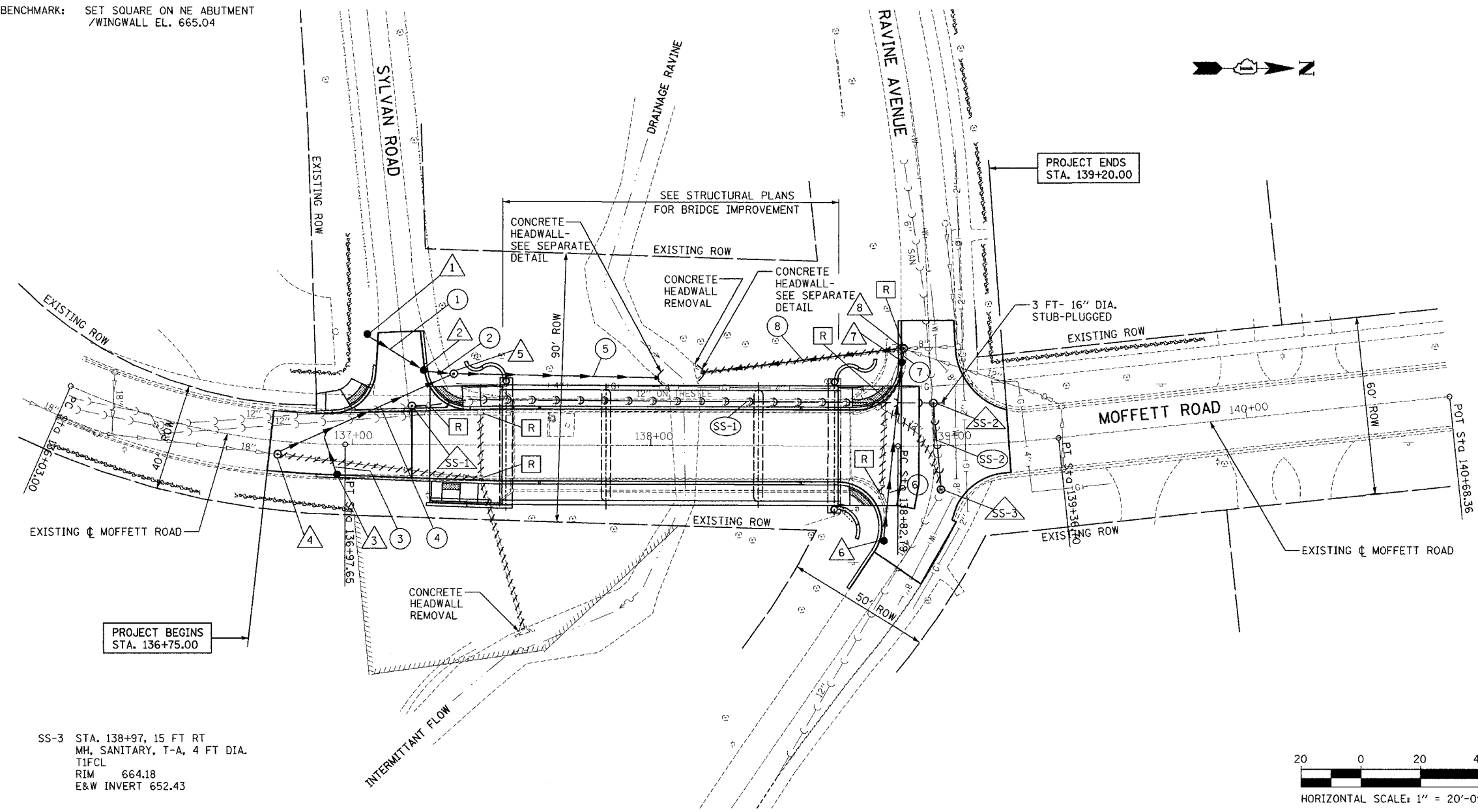

F.A.U. RTE.	SECTION	COUNTY	TOTAL SHEETS	SHEET NO.
2758	02-00025-00-BR	LAKE	40	8
STA.		TO STA.		
FED. ROAD DIST. NO.		ILLINOIS FED. AID PROJECT		
CONTRACT NO. 83790				

- PIPE
- 1 SS, RCCP, TY 2
12" DIA.
20 FT @ 2.00%
22 CY TB
 - 2 SS, RCCP, TY 2
12" DIA.
9 FT @ 2.00%
10 CY TB
 - 3 SS, RCCP, TY 2
12" DIA.
14 FT @ 2.00%
11 CY TB
 - 4 SS, RCCP, TY 2
18" DIA.
65 FT @ 0.15%
101 CY TB
 - 5 PIPE DRAIN, SPECIAL
12" DIA.
77 FT
27 CY TB
 - 6 SS, RCCP, TY 2
12" DIA.
63 FT @ 1.00%
44 CY TB
 - 7 SS, RCCP, TY 2
12" DIA.
8 FT @ 2.00%
6 CY TB
 - 8 PIPE DRAIN, SPECIAL
12" DIA.
73 FT
0 CY TB
 - SS-1 SAN SEWER, DIP, CL 52, SPECIAL
20" DIA.
177 FT @ 0.80%
102 CY TB
 - SS-2 SAN SEWER, DIP, CL 52
16" DIA.
28 FT @ 0.54%
55 CY TB

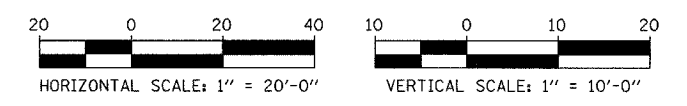

DATE	BY	REVISION

DATE	BY	REVISION

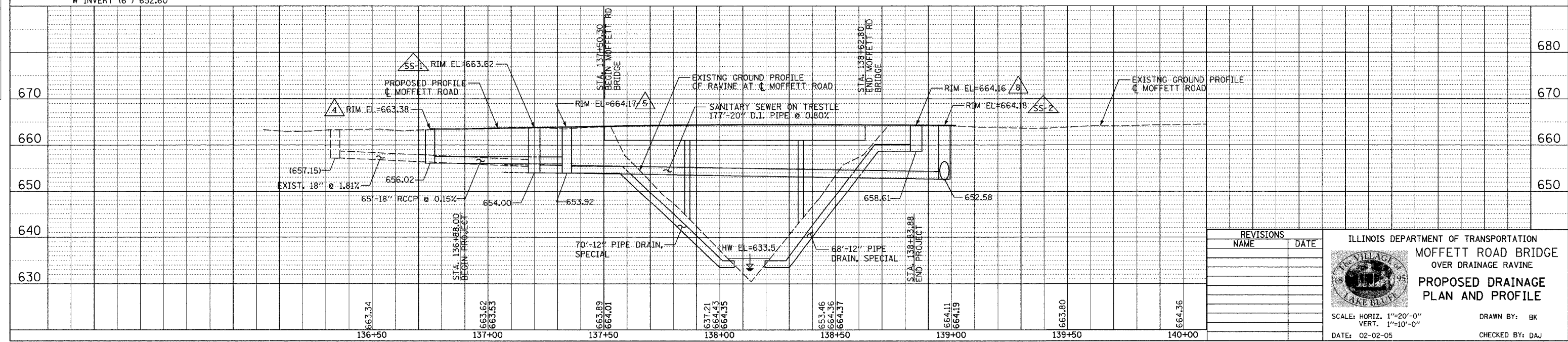

REVISIONS	
NAME	DATE

ILLINOIS DEPARTMENT OF TRANSPORTATION
MOFFETT ROAD BRIDGE
OVER DRAINAGE RAVINE
PROPOSED DRAINAGE
PLAN AND PROFILE

SCALE: HORIZ. 1"=20'-0"
VERT. 1"=10'-0"
DATE: 02-02-05
DRAWN BY: BK
CHECKED BY: DAJ

LEGEND

PERIMETER EROSION BARRIER MODIFIED

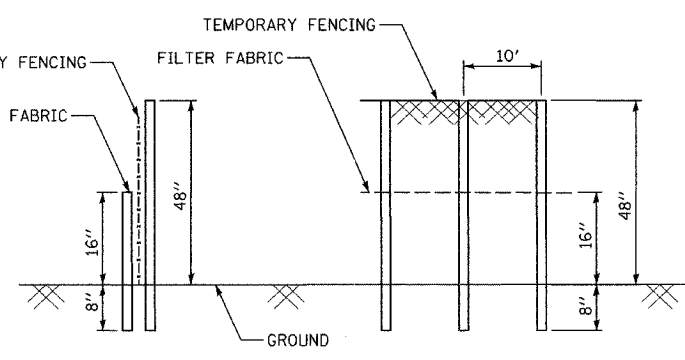
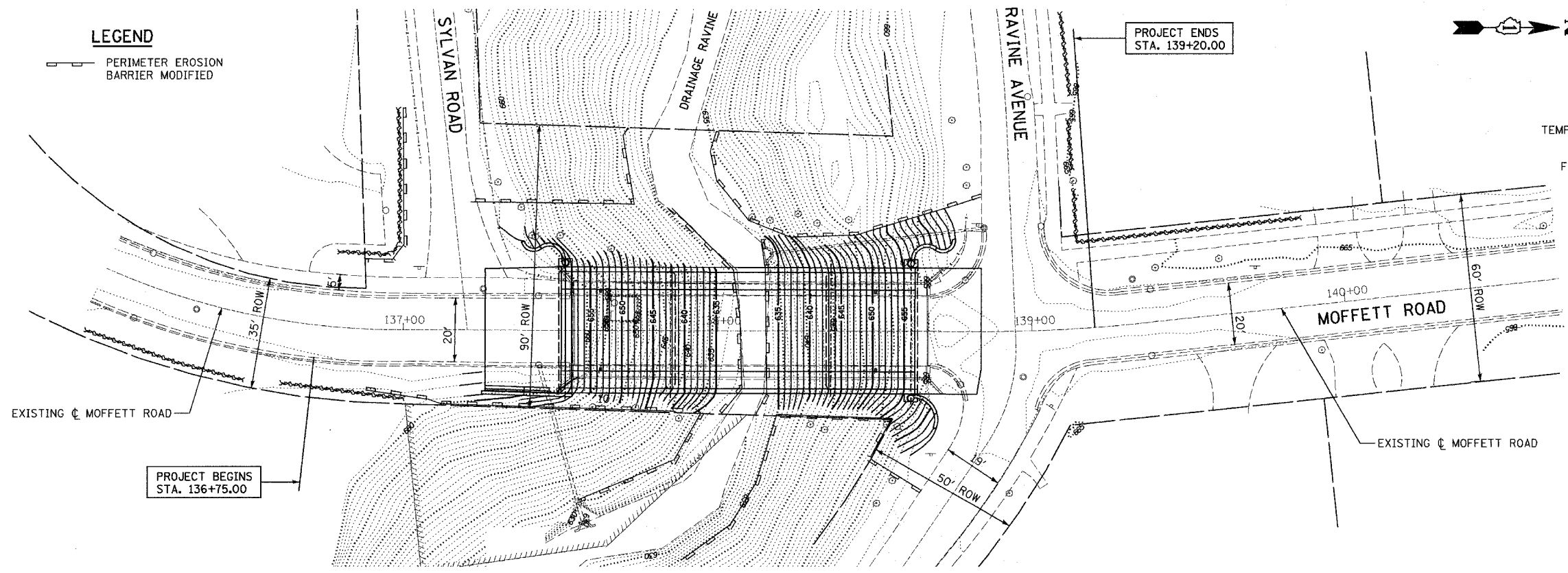

PERIMETER EROSION BARRIER, MODIFIED DETAIL

1. TEMPORARY FENCE SHALL BE FASTENED SECURELY TO THE FENCE POSTS WITH WIRE TIES.
2. FILTER FABRIC SHALL BE FASTENED SECURELY TO THE TEMPORARY FENCE WITH WIRE TIES.

GRADING PLAN

LEGEND

- SODDING - SALT TOLERANT, 4" TOPSOIL AND NUTRIENTS
- SEEDING CLASS 3 (SPECIAL), 4" TOPSOIL, NUTRIENTS, WITH EROSION CONTROL BLANKET
- RIP RAP CLASS A3 W/FILTER FABRIC
- RIP RAP CLASS A5 W/FILTER FABRIC

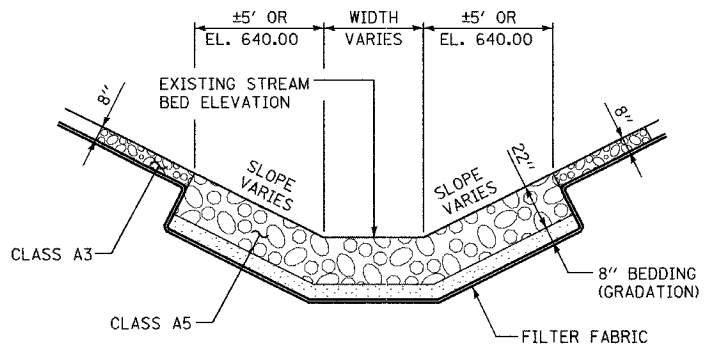
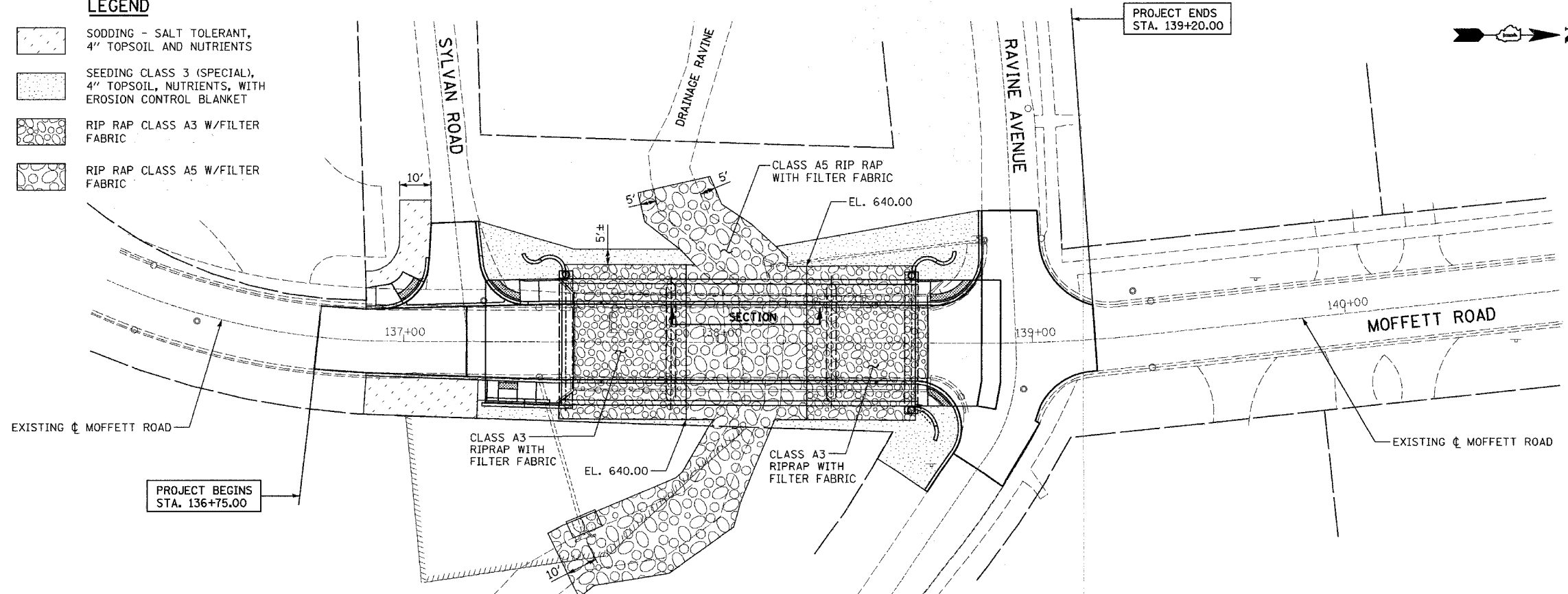

SECTION CLASS A5 RIPRAP

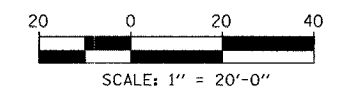

LANDSCAPING PLAN

REVISIONS	NAME	DATE

ILLINOIS DEPARTMENT OF TRANSPORTATION
 MOFFETT ROAD BRIDGE OVER DRAINAGE RAVINE
 GRADING AND LANDSCAPING PLAN
 SCALE: 1"=20'-0"
 DATE: 02-02-05
 DRAWN BY: BK
 CHECKED BY: DAJ

DATE	BY	DATE	BY

DATE	BY	DATE	BY

STATE OF ILLINOIS
DEPARTMENT OF TRANSPORTATION

F.A.U. RTE.	SECTION	COUNTY	TOTAL SHEETS	SHEET NO.
275B D2-00025-00-BR	LAKE		40	11
FED. ROAD DIST. NO.	ILLINOIS	FED. AID PROJECT		

SHEET NO. 1
30 SHEETS

CONTRACT 83790

Benchmark: Set Square on NE abutment/wingwall El. 665.04

Existing Structure: S.N. 049-6801. Built in 1964 as Moffett Road Bridge Section 44-12-1B-CA (Part 1B) (County) and Section 8B-CS (Part 1B) (Village). 3-Span P.P.C. deck on open abutments. 114'-9" Back to Back of Abutments, 31'-0" Out of Out Deck. Structure is to be removed. Traffic will be detoured during construction.

Salvage: None.

LOADING HS20-44

Allow 50#/sq. ft. for future wearing surface

DESIGN SPECIFICATIONS

AASHTO 2002 Standard Specifications for Highway Bridges, 17th Edition

DESIGN STRESSES

FIELD UNITS

$f'_c = 3,500$ psi
 $f_y = 60,000$ psi (Reinforcement)

PRECAST PRESTRESSED UNITS

$f'_c = 6,000$ psi
 $f'_ci = 5,000$ psi
 $f'_s = 270,000$ psi ($\frac{1}{2}$ " ϕ low lax. strands)
 $f_{si} = 201,960$ psi ($\frac{1}{2}$ " ϕ low lax. strands)

SEISMIC DATA

Seismic Performance Category (SPC) = A
Bedrock Acceleration Coefficient (A) = 3.5%
Site Coefficient (S) = 1.0

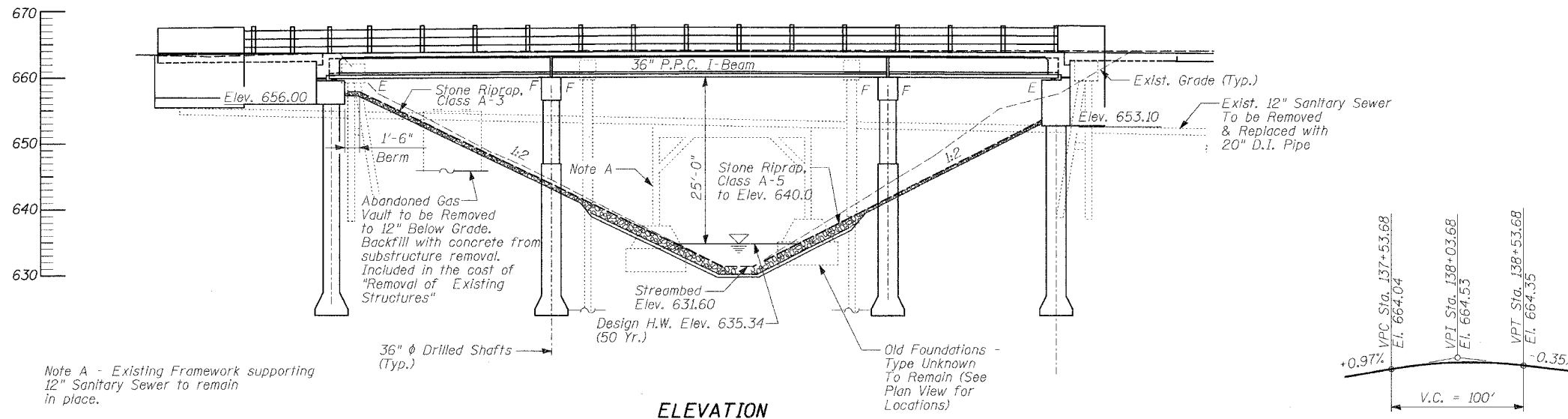

Note A - Existing Framework supporting 12" Sanitary Sewer to remain in place.

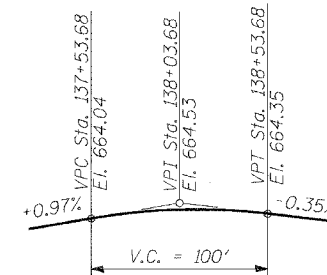

PROFILE GRADE
(along ϕ roadway)

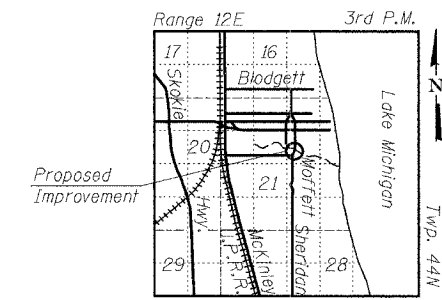
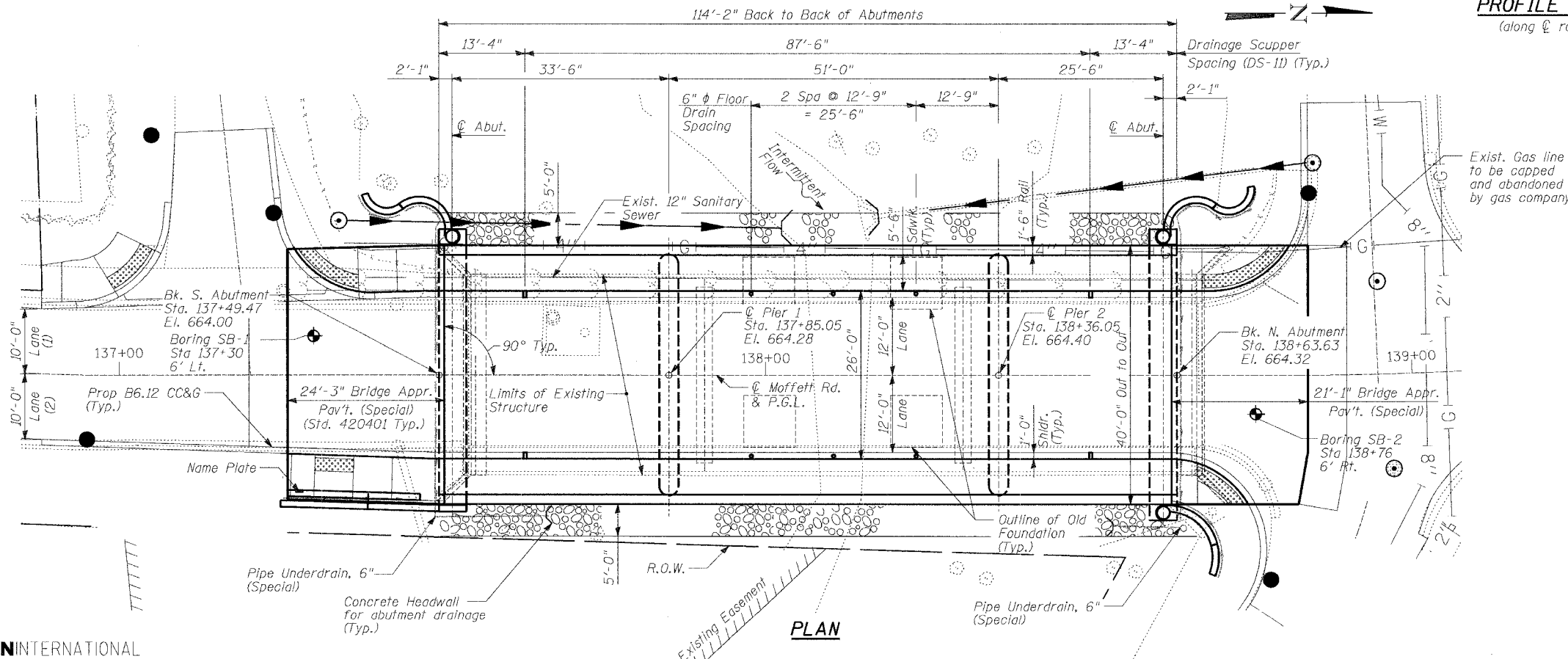

LOCATION SKETCH

I certify that to the best of my knowledge, information and belief, this bridge design is structurally adequate for the design loading shown on the plans. The design is an economical one for the style of the structure and complies with requirements of the current "AASHTO STANDARD SPECIFICATIONS FOR HIGHWAY BRIDGES."



Signed Phillip D. Frey
Phillip D. Frey, S.E. II, Lic. No. 081-004826
Expires 11-30-2005.
Date 2/23/05

GENERAL PLAN AND ELEVATION

MOFFETT ROAD OVER
DRAINAGE RAVINE
FAU 2758
LAKE COUNTY
S.N. 049-6803

TYLIN INTERNATIONAL

DESIGNED	SP, DR
CHECKED	SP
DRAWN	SP, DR
CHECKED	PF
DATE	12-22-2004

(1) Lane width varies from 10'-0" at Sta. 137+88.00 to 12'-0" at Sta. 137+48.14.
(2) Lane width varies from 10'-0" at Sta. 137+88.00 to 12'-0" at Sta. 137+48.21.

GENERAL NOTES

Reinforcement bars shall conform to the requirements of AASHTO M31, M42, or M53 Grade 60.

Layout of slope protection system may be varied in the field to suit ground conditions as directed by the Engineer.

All construction joints shall be bonded.

Contractor shall be responsible for the design, installation, and subsequent removal of any temporary embankment or support system as required to provide equipment access for drilled shaft installation. Cost shall be included in the unit price for Drilled Shaft in Soil, 36".

INDEX OF SHEETS

1. GENERAL PLAN AND ELEVATION
2. GENERAL NOTES / BILL OF MATERIAL
3. TOP OF SLAB ELEVATIONS LAYOUT
4. TOP OF SLAB ELEVATIONS
5. SUPERSTRUCTURE
6. SUPERSTRUCTURE DETAILS - I
7. SUPERSTRUCTURE DETAILS - II
8. RAILING DETAILS
9. STEEL DRAINAGE SCUPPER
10. FRAMING PLAN
11. BEAM DETAILS-SPAN 1
12. BEAM DETAILS-SPAN 2
13. BEAM DETAILS-SPAN 3
14. BEARING DETAILS
15. SOUTH ABUTMENT
16. SOUTH ABUTMENT DETAILS
17. NORTH ABUTMENT
18. NORTH ABUTMENT DETAILS
19. PIER 1
20. PIER 2
21. ANCHOR BOLT DETAILS
22. BAR SPLICER DETAILS
23. SOUTH APPROACH PAVEMENT
24. NORTH APPROACH PAVEMENT
25. APPROACH PAVEMENT DETAILS
26. ARCHITECTURAL DETAILS
27. SOUTH ABUTMENT RETAINING WALLS
28. NORTH ABUTMENT RETAINING WALLS
29. BORING LOGS
30. BORING LOGS

TOTAL BILL OF MATERIAL

Item	Unit	Super.	Sub.	Total
POROUS GRANULAR EMBANKMENT	CU YD		351	351
BRIDGE APPROACH PAVEMENT (SPECIAL)	SQ YD	202		202
REMOVAL OF EXISTING STRUCTURES	EACH	1		1
STRUCTURE EXCAVATION	CU YD		384	384
FLOOR DRAINS	EACH	6		6
CONCRETE STRUCTURES, SPECIAL	CU YD		161.6	161.6
CONCRETE SUPERSTRUCTURE	CU YD	195		195
BRIDGE DECK GROOVING	SQ YD	300		300
PROTECTIVE COAT	SQ YD	519		519
ELASTOMERIC BEARING ASSEMBLY, TYPE I	EACH	12		12
F&E PP CON I-BM 36"	FOOT	662		662
FURNISHING & ERECTING STRUCTURAL STEEL	POUND	551		551
REINFORCEMENT BARS	POUND		15,140	15,140
REINFORCEMENT BARS, EPOXY COATED	POUND	34130	26560	60,690
NAME PLATES	EACH	1		1
GEOCOMPOSITE WALL DRAIN	SQ YD		71	71
PIPE UNDERDRAINS, 6" (SPECIAL)	FOOT		30	30
COATING SYSTEM FOR CONCRETE	SQ FT	1627	2373	4,000
DRAINAGE SCUPPERS, DS-II	EACH	4		4
FORM LINER TEXTURED SURFACE	SQ YD		123	123
ORNAMENTAL RAILING	FOOT	230		230
BAR SPLICERS	EACH	80		80
DRILLED SHAFT IN SOIL, 36"	FOOT		322	322
ARCHITECTURAL CONCRETE	CU YD		9.7	9.7

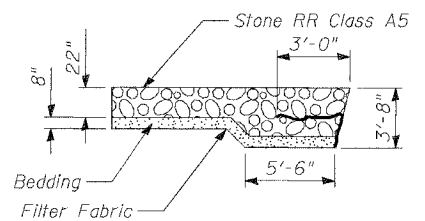

RIPRAP ANCHOR DETAIL

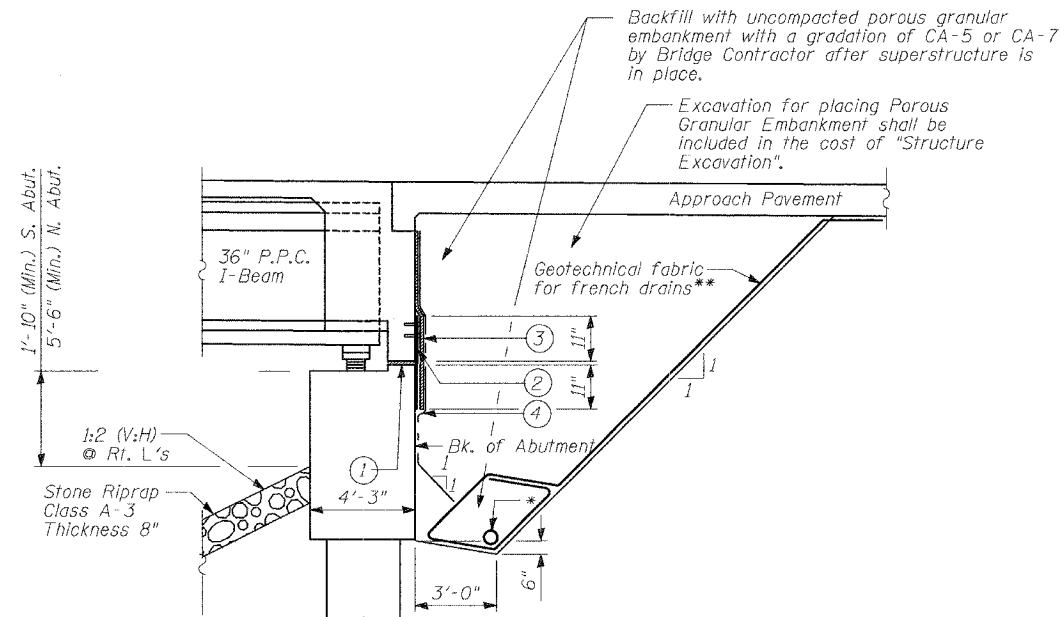

SECTION THRU SEMI-INTEGRAL ABUTMENT

- ** Included in the cost of "Porous Granular Embankment".
- * A 6" ϕ perforated drain pipe shall be situated at the bottom of an approximate 2'x2' area of porous granular embankment. The 2'x2' area shall be wrapped completely in geotechnical fabric for french drains. The pipe, porous granular material, and geotechnical fabric for french drains shall be included in the cost of Concrete Structures, Special. Pipes shall drain onto concrete headwalls (Article 601.05 of the Std. Specifications and Highway Std. 601101).
- 1 2" Preformed Joint Filler (Section 1051 of the Standard Specifications) bonded to abutment cap with approved adhesive (full width of cap)
 - 2 Fabric Reinforced Elastomeric Mat (See Special Provisions). Fabric mat shall be 24" wide and attached full width to the abutment cap with a 3/8" x 5" steel plate and 1/2" ϕ studs with nuts and washers at 12" cts.
 - 3 2" Preformed Joint Filler (Section 1051 of the Standard Specifications) bonded to the superstructure (full width of cap)
 - 4 Geocomposite Wall Drain (Section 591 of the Standard Specifications - full width of cap).

Items 1 2 3 & 4 shall be Included in the cost of Concrete Superstructure

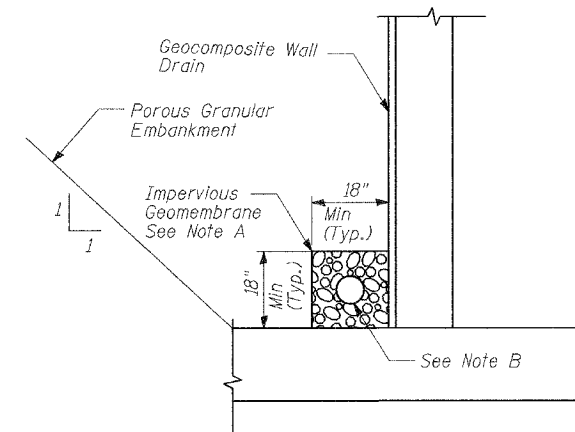

SECTION THRU ABUTMENT WINGWALLS AND CANTILEVER RETAINING WALLS

Note A
Cost included with Geocomposite Wall Drain

Note B:
6" Perforated pipe drain according to Section 601 of the Standard Specifications, encased in 18" of CA-5 or CA-7 course aggregate. Cost included with Concrete Structures, Special.

STATION 138+06.55
BUILT 200 BY
VILLAGE OF LAKE BLUFF
SEC. 02-00025-00-BR
F.A.U. RT. 2758
STR. NO. 049-6803 LOADING HS20

NAME PLATE
See Std. 515001

TYLIN INTERNATIONAL

DESIGNED	- SP
CHECKED	- PF
DRAWN	- SP
CHECKED	- PF

DATE: 02-23-2005

GENERAL NOTES/BILL OF MATERIAL

MOFFETT ROAD OVER
DRAINAGE RAVINE
FAU 2758
LAKE COUNTY
S.N. 049-6803

STATE OF ILLINOIS
DEPARTMENT OF TRANSPORTATION

ROUTE NO.	SECTION	COUNTY	TOTAL SHEETS	SHEET NO.	SHEET NO. - 3 30 - SHEETS CONTRACT 83790
2758	*	LAKE	40	13	
FED. ROAD DIST. NO.		ILL. HIGHWAY PROJECT		* 02-00025-00-BR	

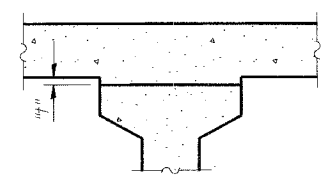
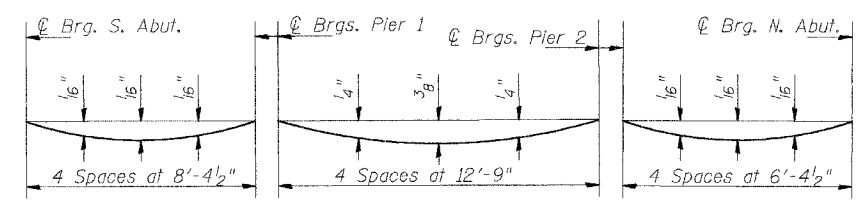
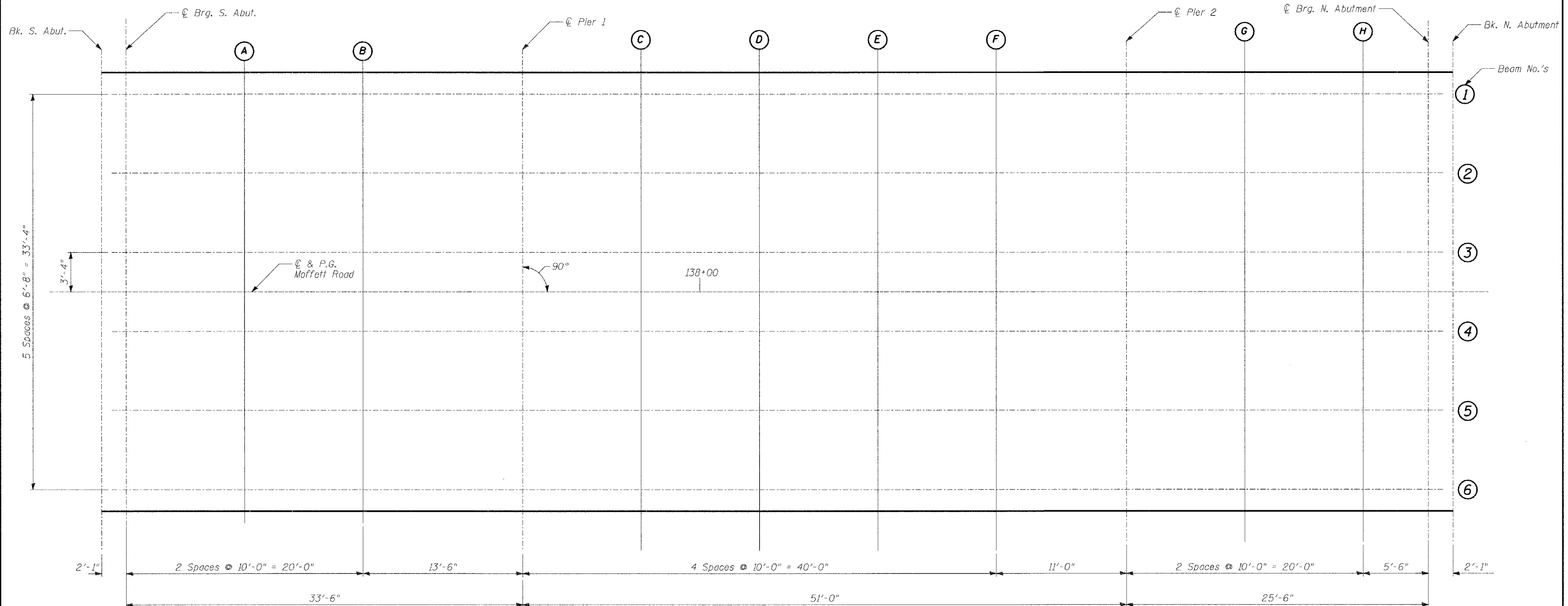

To determine "h": After all precast prestressed beams have been erected, elevations of the top flanges of the beams shall be taken at intervals shown below. These elevations subtracted from the "Theoretical Grade Elevations Adjusted for Dead Load Deflections" minus slab thickness, equals the fillet heights "h" above top flanges of beams.

PLAN

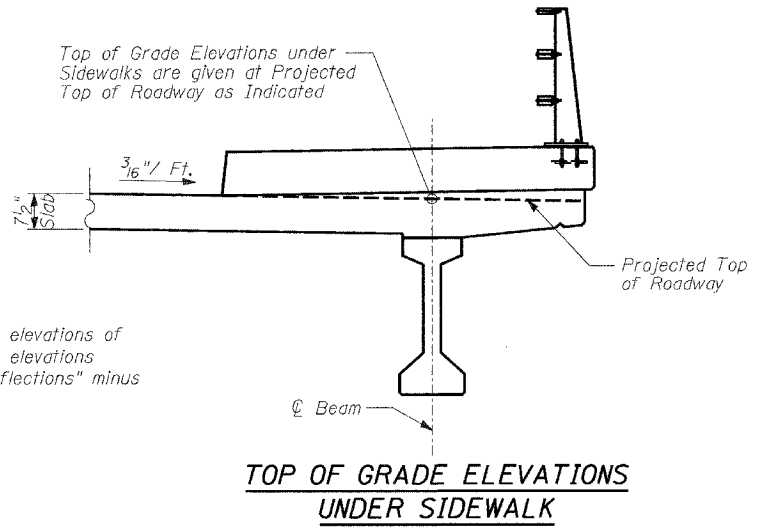

TYLIN INTERNATIONAL

DESIGNED	- DE
CHECKED	- SP
DRAWN	- SP DE
CHECKED	- PF

DATE: 01-28-2005

TOP OF SLAB ELEVATIONS - LAYOUT

MOFFETT ROAD OVER
DRAINAGE RAVINE
FAU 2758
LAKE COUNTY
S.N. 049-6803

STATE OF ILLINOIS
DEPARTMENT OF TRANSPORTATION

ROUTE NO.	SECTION	COUNTY	TOTAL SHEETS	SHEET NO.
2758	*	LAKE	40	14
FED. ROAD DIST. NO.		ILLINOIS	FED. AID PROJECT-	CONTRACT 83790
* 02-00025-00-BR				

BEAM 1

Location	Station	Offset	Theoretical Grade Elevations	Theoretical Grade Elevations Adjusted For Dead Load Deflection
BK. OF S. ABUT.	137+49.47	-16.67	663.744	663.744
Q BRG. S. ABUT.	137+51.55	-16.67	663.764	663.764
A	137+61.55	-16.67	663.857	663.862
B	137+71.55	-16.67	663.937	663.943
Q PIER 1	137+85.05	-16.67	664.024	664.024
C	137+95.05	-16.67	664.073	664.094
D	138+05.05	-16.67	664.109	664.141
E	138+15.05	-16.67	664.131	664.164
F	138+25.05	-16.67	664.141	664.164
Q PIER 2	138+36.05	-16.67	664.136	664.136
G	138+46.05	-16.67	664.117	664.120
H	138+56.05	-16.67	664.086	664.088
Q BRG. N. ABUT.	138+61.55	-16.67	664.067	664.067
BK. OF N. ABUT.	138+63.63	-16.67	664.060	664.060

BEAM 2

Location	Station	Offset	Theoretical Grade Elevations	Theoretical Grade Elevations Adjusted For Dead Load Deflection
BK. OF S. ABUT.	137+49.47	-10.00	663.848	663.848
Q BRG. S. ABUT.	137+51.55	-10.00	663.868	663.868
A	137+61.55	-10.00	663.961	663.967
B	137+71.55	-10.00	664.041	664.047
Q PIER 1	137+85.05	-10.00	664.128	664.128
C	137+95.05	-10.00	664.177	664.199
D	138+05.05	-10.00	664.213	664.245
E	138+15.05	-10.00	664.235	664.269
F	138+25.05	-10.00	664.245	664.268
Q PIER 2	138+36.05	-10.00	664.240	664.240
G	138+46.05	-10.00	664.222	664.224
H	138+56.05	-10.00	664.190	664.192
Q BRG. N. ABUT.	138+61.55	-10.00	664.171	664.171
BK. OF N. ABUT.	138+63.63	-10.00	664.164	664.164

BEAM 3

Location	Station	Offset	Theoretical Grade Elevations	Theoretical Grade Elevations Adjusted For Dead Load Deflection
BK. OF S. ABUT.	137+49.47	-3.33	663.952	663.952
Q BRG. S. ABUT.	137+51.55	-3.33	663.972	663.972
A	137+61.55	-3.33	664.065	664.071
B	137+71.55	-3.33	664.145	664.152
Q PIER 1	137+85.05	-3.33	664.232	664.232
C	137+95.05	-3.33	664.281	664.303
D	138+05.05	-3.33	664.317	664.350
E	138+15.05	-3.33	664.340	664.373
F	138+25.05	-3.33	664.349	664.372
Q PIER 2	138+36.05	-3.33	664.344	664.344
G	138+46.05	-3.33	664.326	664.328
H	138+56.05	-3.33	664.295	664.296
Q BRG. N. ABUT.	138+61.55	-3.33	664.275	664.275
BK. OF N. ABUT.	138+63.63	-3.33	664.268	664.268

Q MOFFETT ROAD

Location	Station	Offset	Theoretical Grade Elevations	Theoretical Grade Elevations Adjusted For Dead Load Deflection
BK. OF S. ABUT.	137+49.47	0.00	664.004	664.004
Q BRG. S. ABUT.	137+51.55	0.00	664.024	664.024
A	137+61.55	0.00	664.117	664.123
B	137+71.55	0.00	664.197	664.204
Q PIER 1	137+85.05	0.00	664.284	664.284
C	137+95.05	0.00	664.333	664.355
D	138+05.05	0.00	664.369	664.402
E	138+15.05	0.00	664.392	664.425
F	138+25.05	0.00	664.401	664.424
Q PIER 2	138+36.05	0.00	664.396	664.396
G	138+46.05	0.00	664.378	664.380
H	138+56.05	0.00	664.347	664.348
Q BRG. N. ABUT.	138+61.55	0.00	664.327	664.327
BK. OF N. ABUT.	138+63.63	0.00	664.320	664.320

BEAM 4

Location	Station	Offset	Theoretical Grade Elevations	Theoretical Grade Elevations Adjusted For Dead Load Deflection
BK. OF S. ABUT.	137+49.47	3.33	663.952	663.952
Q BRG. S. ABUT.	137+51.55	3.33	663.972	663.972
A	137+61.55	3.33	664.065	664.071
B	137+71.55	3.33	664.145	664.152
Q PIER 1	137+85.05	3.33	664.232	664.232
C	137+95.05	3.33	664.281	664.303
D	138+05.05	3.33	664.317	664.350
E	138+15.05	3.33	664.340	664.373
F	138+25.05	3.33	664.349	664.372
Q PIER 2	138+36.05	3.33	664.344	664.344
G	138+46.05	3.33	664.326	664.328
H	138+56.05	3.33	664.295	664.296
Q BRG. N. ABUT.	138+61.55	3.33	664.275	664.275
BK. OF N. ABUT.	138+63.63	3.33	664.268	664.268

BEAM 5

Location	Station	Offset	Theoretical Grade Elevations	Theoretical Grade Elevations Adjusted For Dead Load Deflection
BK. OF S. ABUT.	137+49.47	10.00	663.848	663.848
Q BRG. S. ABUT.	137+51.55	10.00	663.868	663.868
A	137+61.55	10.00	663.961	663.967
B	137+71.55	10.00	664.041	664.047
Q PIER 1	137+85.05	10.00	664.128	664.128
C	137+95.05	10.00	664.177	664.199
D	138+05.05	10.00	664.213	664.245
E	138+15.05	10.00	664.235	664.269
F	138+25.05	10.00	664.245	664.268
Q PIER 2	138+36.05	10.00	664.240	664.240
G	138+46.05	10.00	664.222	664.224
H	138+56.05	10.00	664.190	664.192
Q BRG. N. ABUT.	138+61.55	10.00	664.171	664.171
BK. OF N. ABUT.	138+63.63	10.00	664.164	664.164

BEAM 6

Location	Station	Offset	Theoretical Grade Elevations	Theoretical Grade Elevations Adjusted For Dead Load Deflection
BK. OF S. ABUT.	137+49.47	16.67	663.744	663.744
Q BRG. S. ABUT.	137+51.55	16.67	663.764	663.764
A	137+61.55	16.67	663.857	663.862
B	137+71.55	16.67	663.937	663.943
Q PIER 1	137+85.05	16.67	664.024	664.024
C	137+95.05	16.67	664.073	664.094
D	138+05.05	16.67	664.109	664.141
E	138+15.05	16.67	664.131	664.164
F	138+25.05	16.67	664.141	664.164
Q PIER 2	138+36.05	16.67	664.136	664.136
G	138+46.05	16.67	664.117	664.120
H	138+56.05	16.67	664.086	664.088
Q BRG. N. ABUT.	138+61.55	16.67	664.067	664.067
BK. OF N. ABUT.	138+63.63	16.67	664.060	664.060

TYLIN INTERNATIONAL

DESIGNED	- DE
CHECKED	- SP
DRAWN	- DE
CHECKED	- PF

DATE: 01-28-2005

TOP OF SLAB ELEVATIONS

MOFFETT ROAD OVER
DRAINAGE RAVINE
FAU 2758
LAKE COUNTY
S.N. 049-6803

STATE OF ILLINOIS
DEPARTMENT OF TRANSPORTATION

ROUTE NO.	SECTION	COUNTY	TOTAL SHEETS	SHEET NO.	SHEET NO. - 5 30 - SHEETS CONTRACT 83790
2758	*	LAKE	40	15	
FED. ROAD DIST. NO.	S.L. INCHES	FED. AID PROJECT	* 02-00025-00-BR		

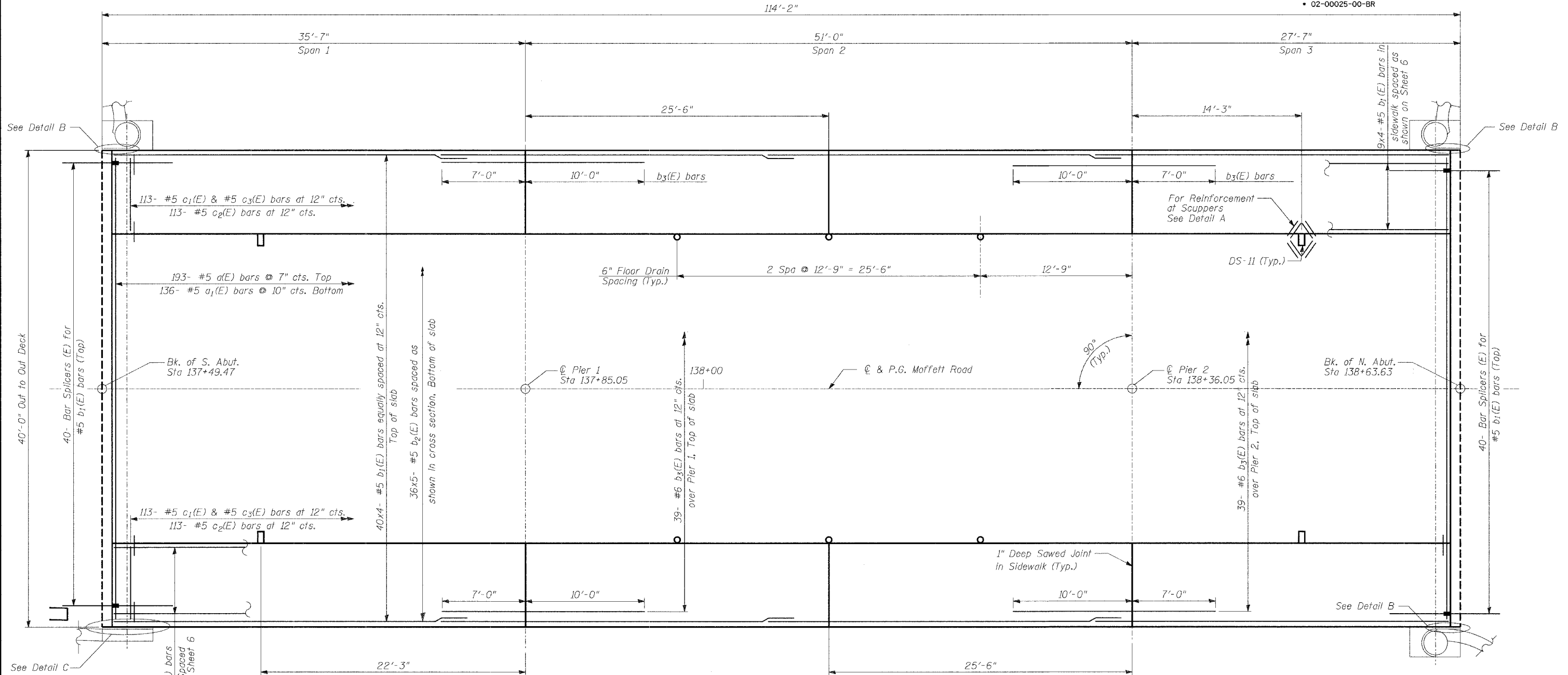

PLAN

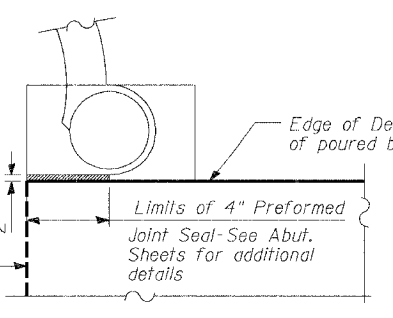

DETAIL B

South Abutment, west edge of deck shown, similar at North Abutment, west edge of deck and east edge of deck

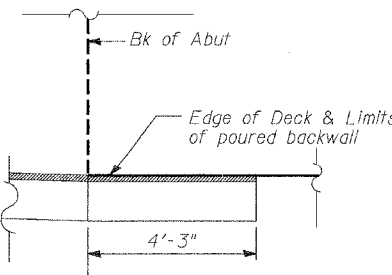

DETAIL C

Note: Work Details B and C with Sheets 16 and 18.

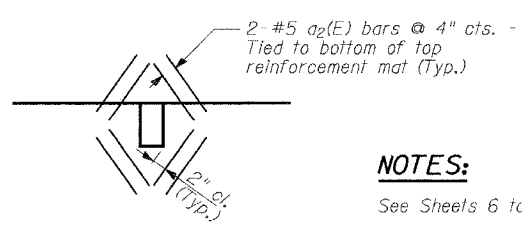

DETAIL A

Cut Longitudinal reinforcement to clear drainage scuppers.

NOTES:

- See Sheets 6 to 10 for additional superstructure details.
- For Bill of Material, See Sheet 6.
- Bars indicated thus: 20 x 3- #5 etc. indicates 20 lines of bars with 3 lengths per line.
- Reinforcement bars designated (E) shall be epoxy coated.
- Minimum lap splice for #5 bars shall be 2'-2".

TYLIN INTERNATIONAL

DESIGNED	- DE
CHECKED	- SP
DRAWN	- DE
CHECKED	- PF

DATE: 02-23-2005

SUPERSTRUCTURE

MOFFETT ROAD OVER
DRAINAGE RAVINE
FAU 2758
LAKE COUNTY
S.N. 049-6803

STATE OF ILLINOIS
DEPARTMENT OF TRANSPORTATION

ROUTE NO.	SECTION	COUNTY	TOTAL SHEETS	SHEET NO.
2758		LAKE	40	16
FED. ROAD DIST. NO.	ILLINOIS	FED. AID PROJECT	CONTRACT 83790	
02-00025-00-BR				

40'-0" Out to Out Deck

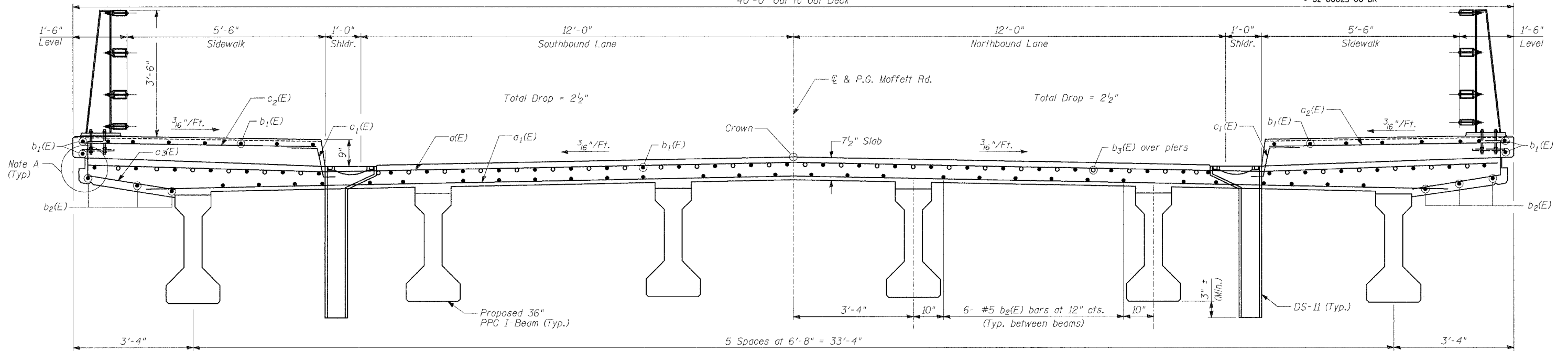

Note A:
For details of notch, See Sheet 26 of 30.
Cost is included with Concrete Superstructure.

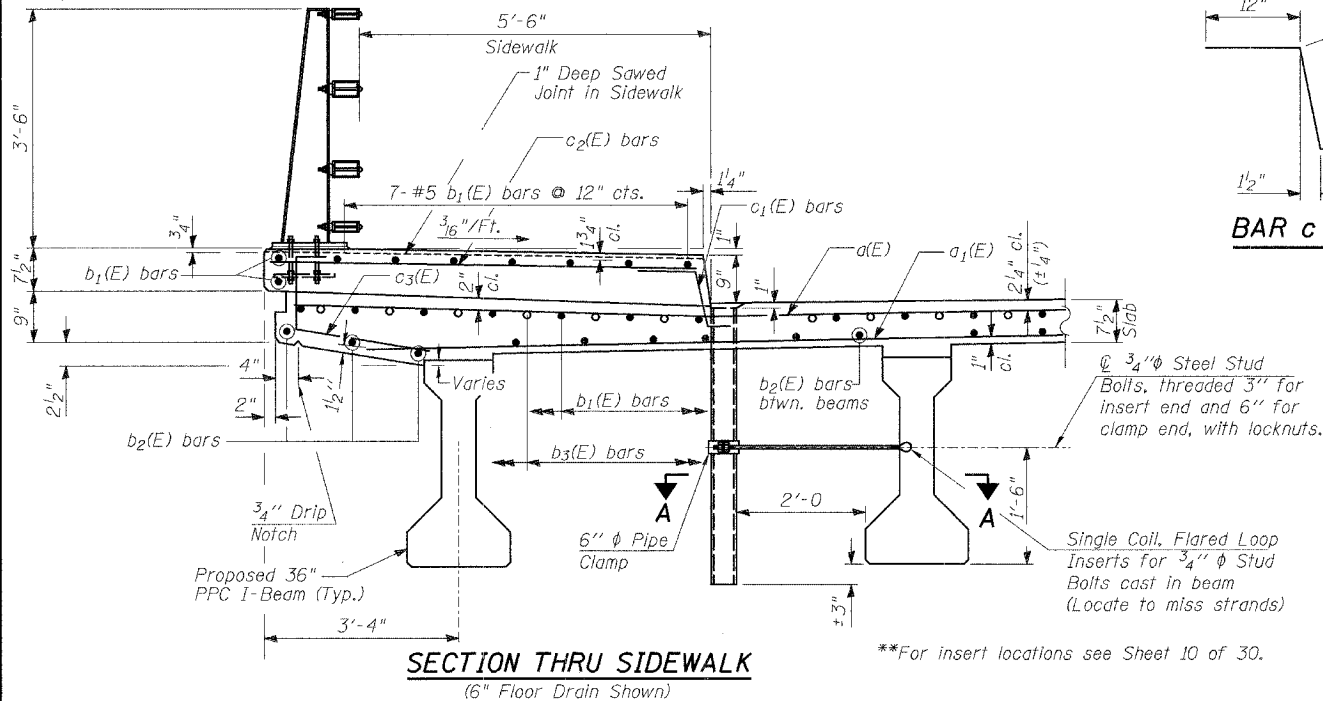

SECTION THRU SUPERSTRUCTURE

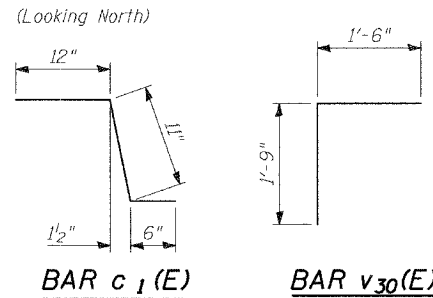

BILL OF MATERIAL

Bar	No.	Size	Length	Shape
$a(E)$	193	#5	39'-4"	—
$a_1(E)$	136	#5	37'-10"	—
$a_2(E)$	32	#5	1'-6"	—
$b_1(E)$	232	#5	29'-8"	—
$b_2(E)$	180	#5	24'-2"	—
$b_3(E)$	78	#6	17'-0"	—
$c_1(E)$	226	#5	2'-5"	┘
$c_2(E)$	226	#5	6'-8"	┘
$c_3(E)$	226	#5	3'-11"	┘
$m_1(E)$	32	#6	21'-0"	—
$m_2(E)$	24	#6	8'-1"	—
$m_3(E)$	40	#6	4'-10"	—
$m_4(E)$	8	#6	2'-1"	—
$m_{10}(E)$	40	#4	5'-10"	—
$m_{11}(E)$	12	#8	5'-6"	—
$s_{30}(E)$	72	#5	7'-7"	┘
$s_{31}(E)$	82	#4	9'-4"	┘
$s_{32}(E)$	70	#4	9'-8"	┘
$u_1(E)$	80	#5	3'-3"	┘
$v_{30}(E)$	80	#5	3'-3"	┘
Concrete Superstructure	CU YD		195	
Reinforcement Bars, Epoxy Coated	POUND		34130	
Bridge Deck Grooving	SQ YD		300	
Protective Coat	SQ YD		519	
Bar Splicers	EACH		80	

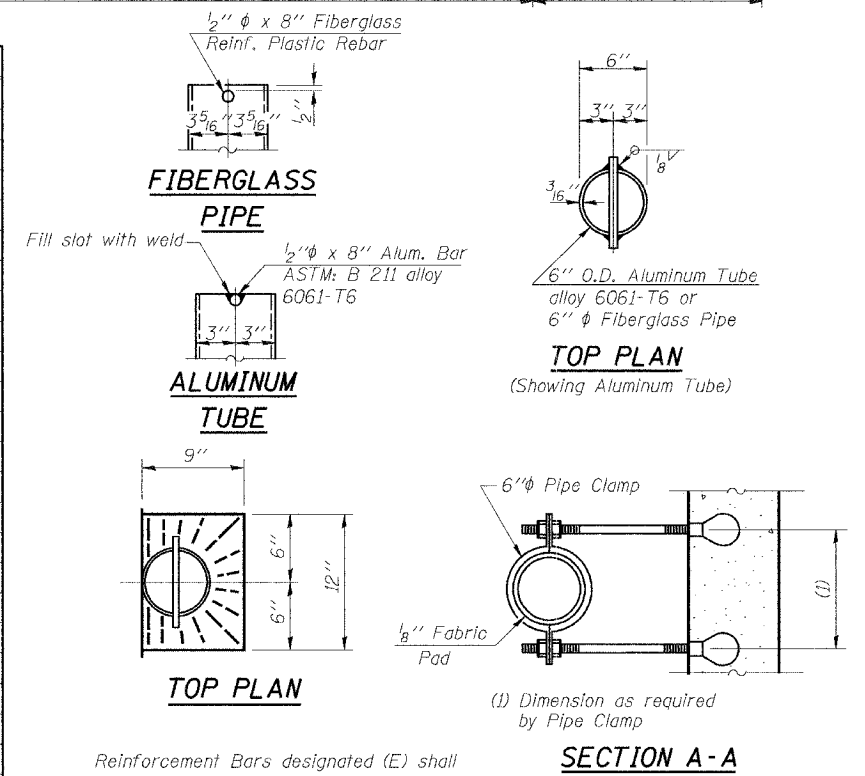

TYLIN INTERNATIONAL

DESIGNED	- DE SP
CHECKED	- SP
DRAWN	- DE
CHECKED	- PF

DATE: 02-23-2005

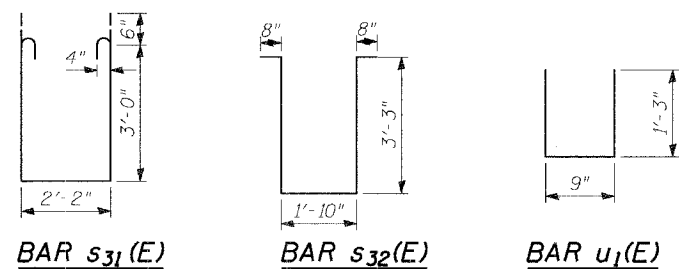

Notes:
Fiberglass pipe shall conform to ASTM D2996, with short-time rupture strength hoop tensile stress of 30,000 p.s.i. minimum.
The exterior surfaces of the floor drains shall be coated or pigmented by the manufacturer with a color that matches the concrete.
The clamping device and inserts shall be galvanized according to AASHTO M 232.

SUPERSTRUCTURE DETAILS I

MOFFETT ROAD OVER
DRAINAGE RAVINE
FAU 2758
LAKE COUNTY
S.N. 049-6803

STATE OF ILLINOIS
DEPARTMENT OF TRANSPORTATION

ROUTE NO.	SECTION	COUNTY	TOTAL SHEETS	SHEET NO.	SHEET NO. - 8
2758	*	LAKE	40	18	30 - SHEETS
FED. ROAD DIST. NO.	ILLINOIS	FED. AID PROJECT	CONTRACT 83790		

NOTES

Hollow structural sections shall conform to the requirements of ASTM designation A 500, Grade B, Structural Steel Tubing and shall meet the longitudinal CVN requirements of 15 ft-lbs at 0°F. All other steel shapes and plates shall conform to the requirements of AASHTO M 270 Grade 36. Bolts, cap screws, and nuts shall conform to the requirements of ASTM designation A 307 except for high strength bolts, nuts and washers noted which shall conform to AASHTO M 164. All bolts, nuts and washers shall be galvanized according to AASHTO M11 and ASTM A385. All other rail elements including railing, posts, splices, plates and wire mesh shall be galvanized and powder coated per the Special Provisions. No field drilling of the HSS sections will be permitted. All welding shall be done in accordance with AWS D1.5 Bridge Welding Code. Use min. size unless noted. Railing shall be according to Section 509 of the Standard Specifications, except as noted, and will be paid for at the contract unit price per foot for ORNAMENTAL RAILING.

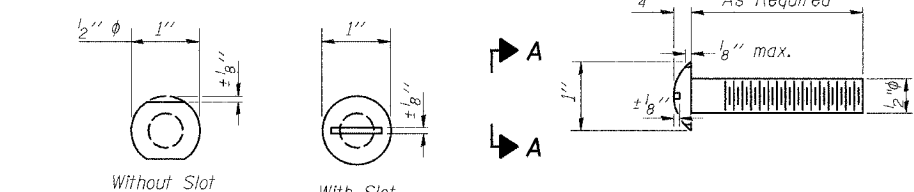
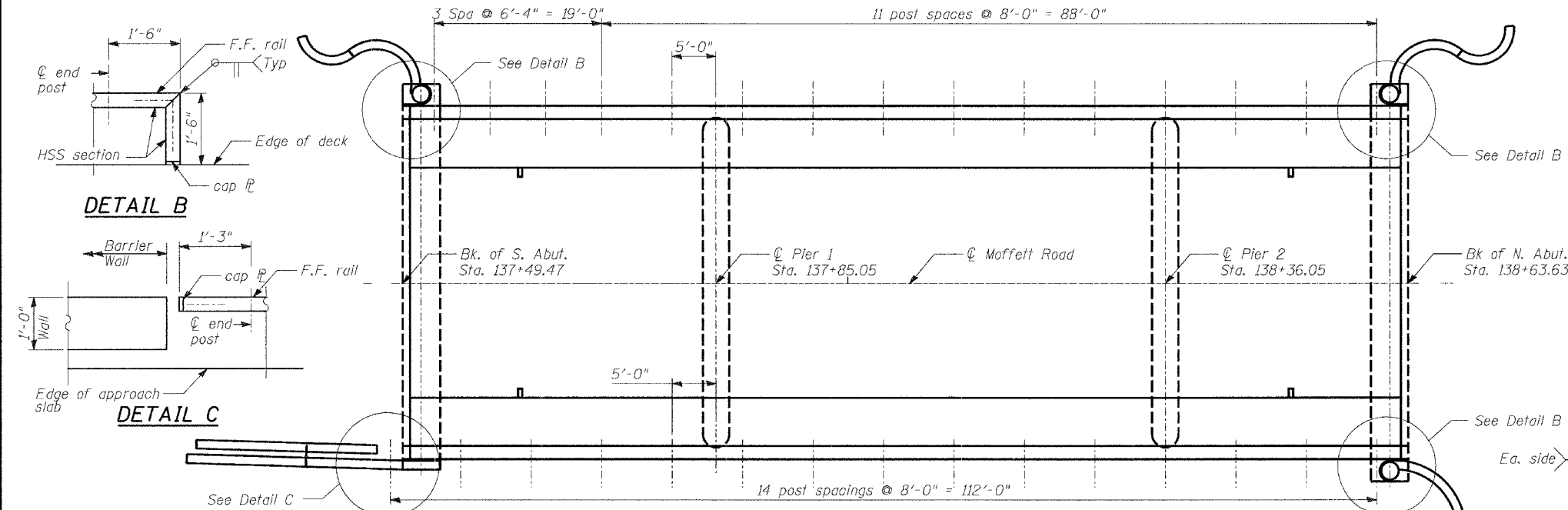

VIEW A-A

DETAIL OF 1/2" ϕ ROUND HEAD BOLTS

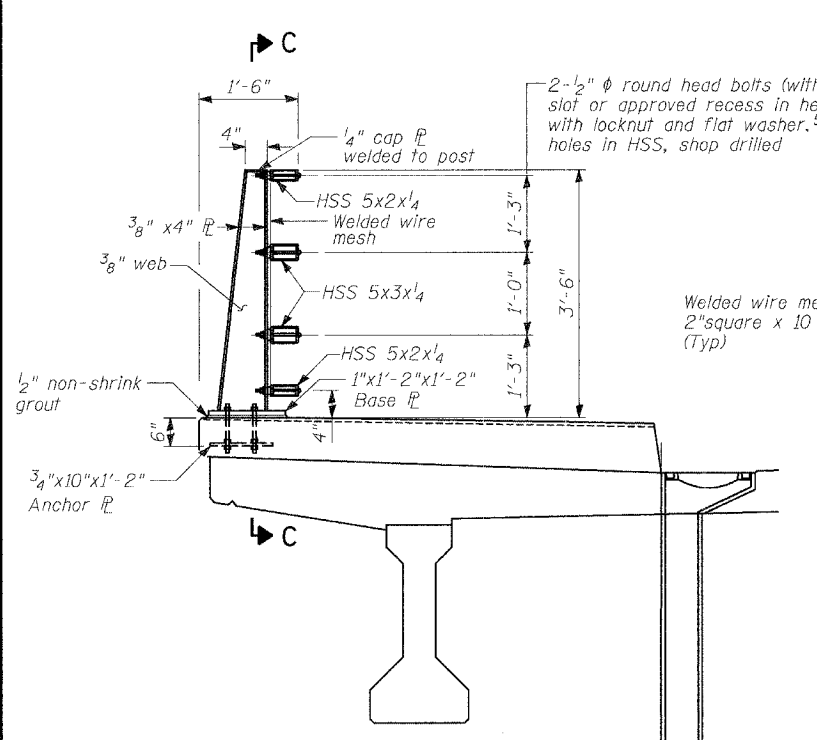

SECTION THRU RAIL

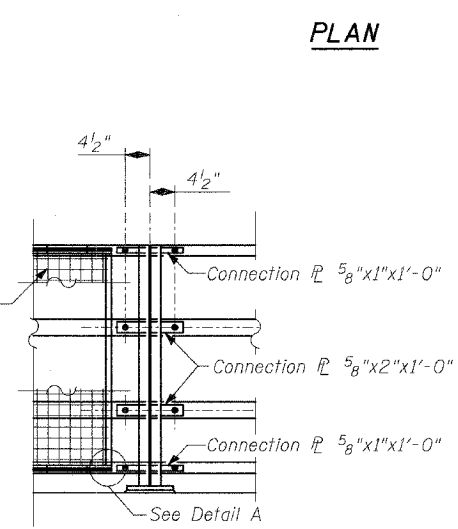

SECTION C-C

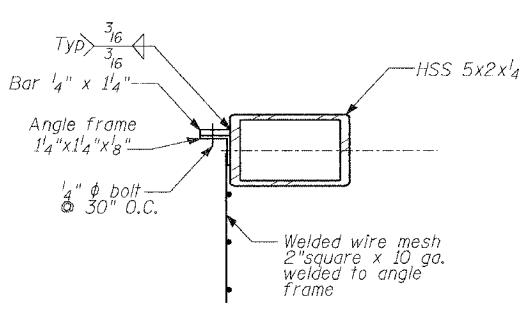

WIRE MESH CONN. AT TOP & BOT. RAIL

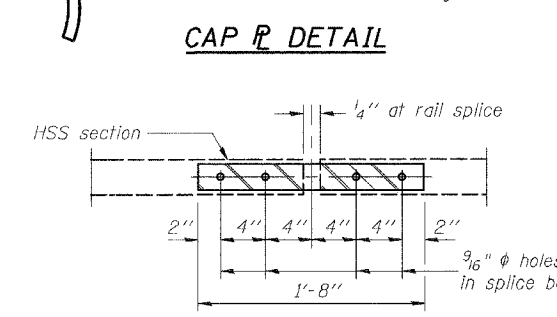

CAP PLATE DETAIL

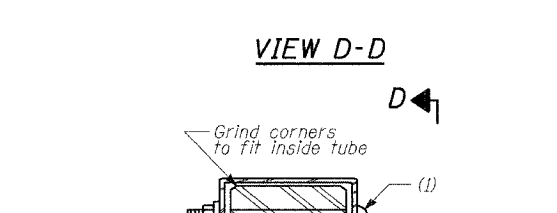

VIEW D-D

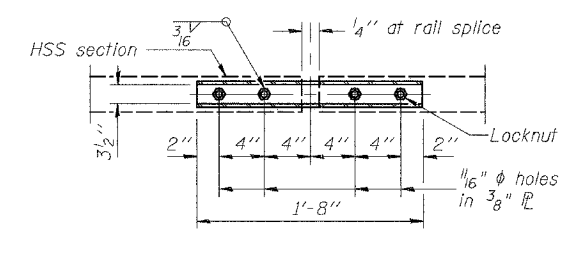

VIEW B-B

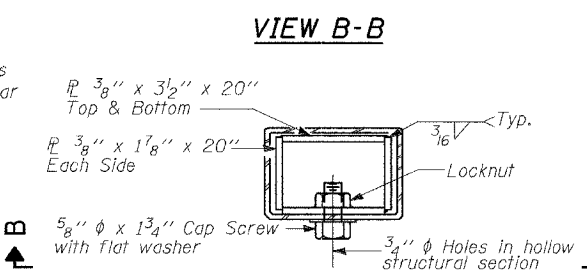

SECTION AT RAIL SPLICE (For HSS 5x3)

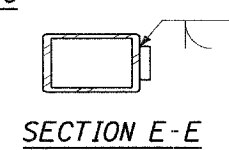

SECTION E-E

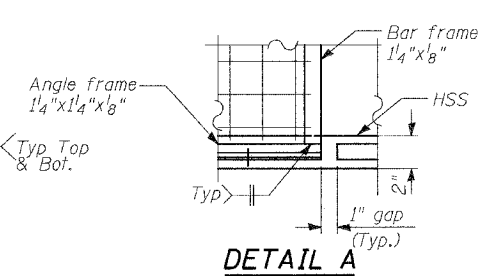

DETAIL A

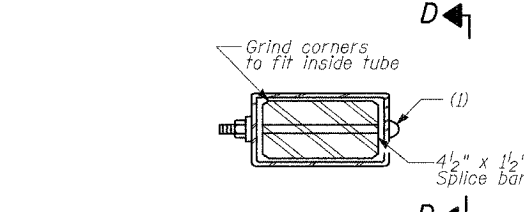

SECTIONS AT RAIL SPLICE (For HSS 5x2)

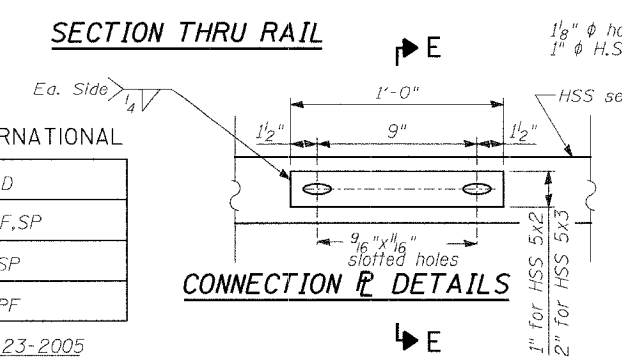

CONNECTION PLATE DETAILS

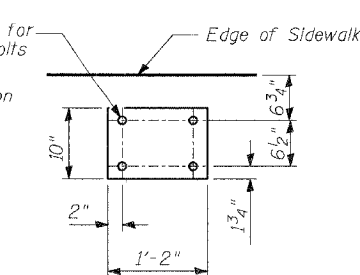

ANCHOR PLATE DETAILS

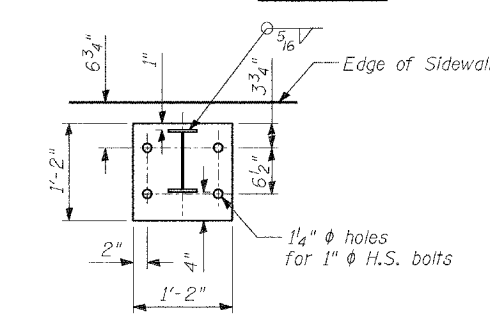

BASE PLATE DETAILS

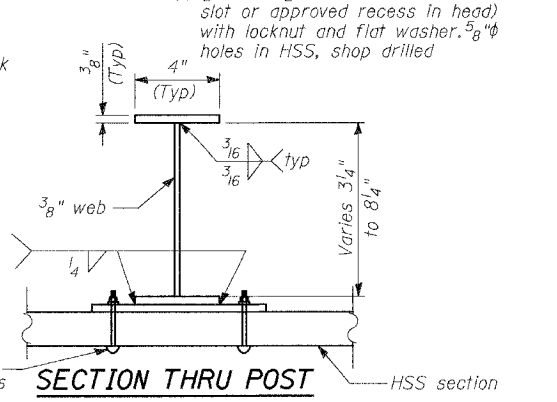

SECTION THRU POST

TYLIN INTERNATIONAL

DESIGNED	- AD
CHECKED	- PF, SP
DRAWN	- SP
CHECKED	- PF

DATE: 02-23-2005

BILL OF MATERIAL

ITEM	UNIT	TOTAL
Ornamental Railing	Foot	230'-0"

RAILING DETAILS

MOFFETT ROAD OVER DRAINAGE RAVINE
FAU 2758
LAKE COUNTY
S.N. 049-6803

STATE OF ILLINOIS
DEPARTMENT OF TRANSPORTATION

ROUTE NO.	SECTION	COUNTY	TOWNSHIP	SHEET NO.	SHEET NO. -9 30 - SHEETS CONTRACT 83790
2758		LAKE	40	19	
FED. ROAD DIST. NO.	ILLINOIS	FED. AID PROJECT	• 02-00025-00-BR		

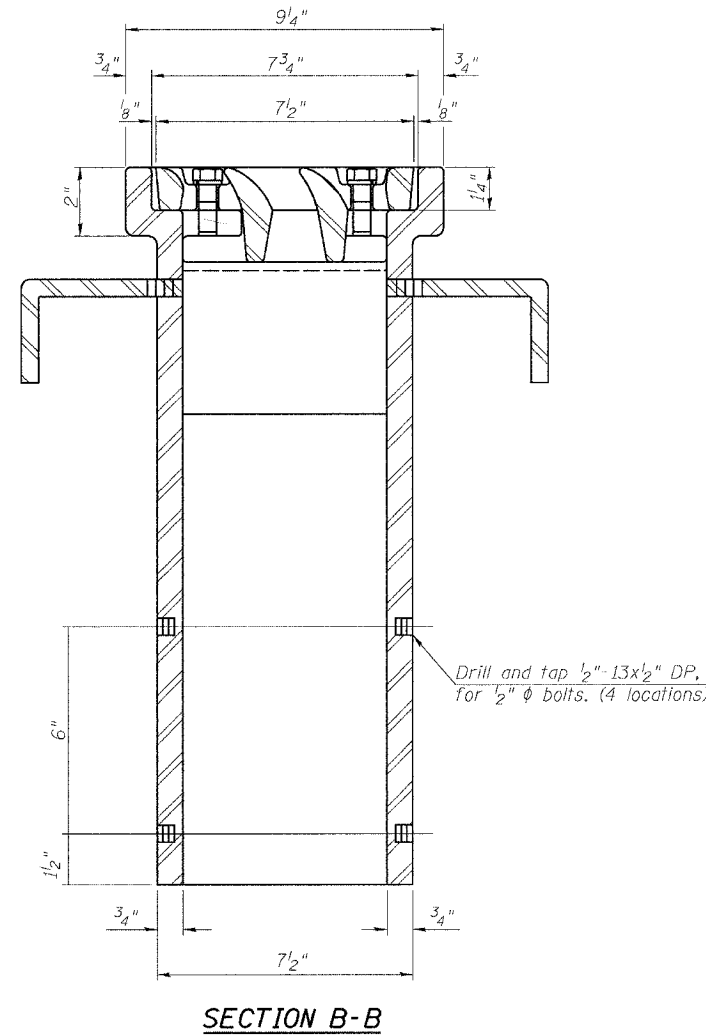
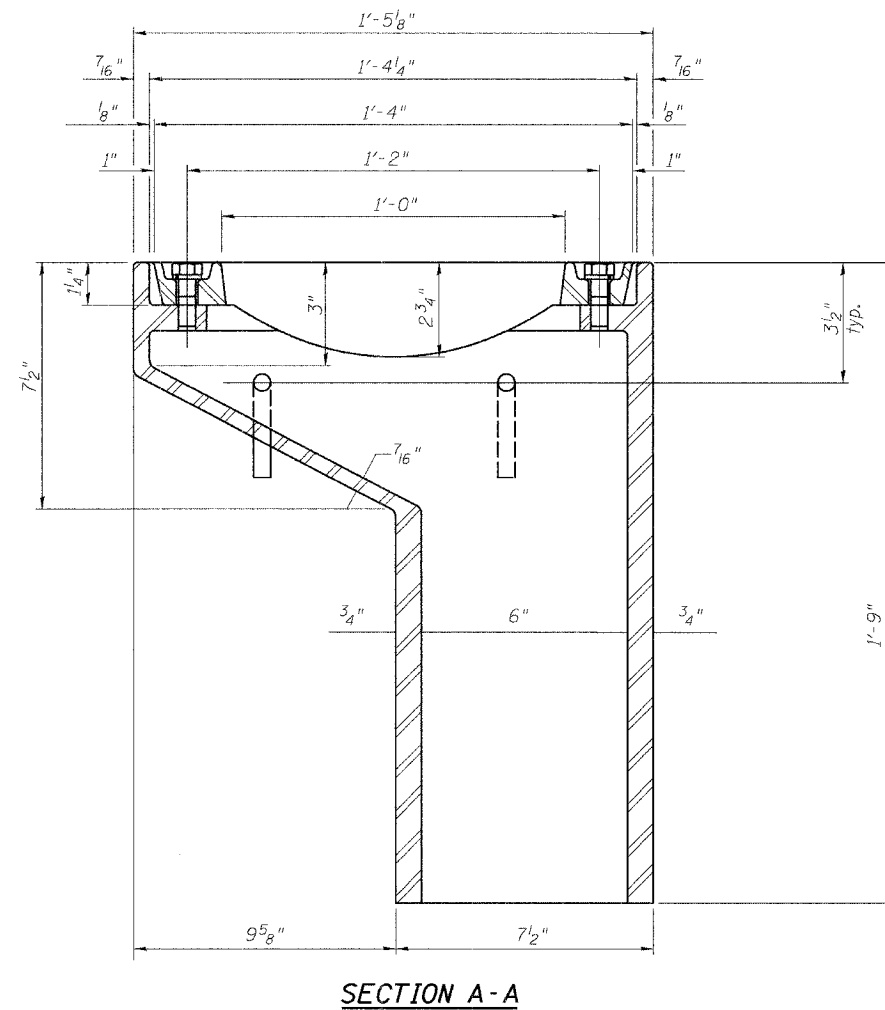
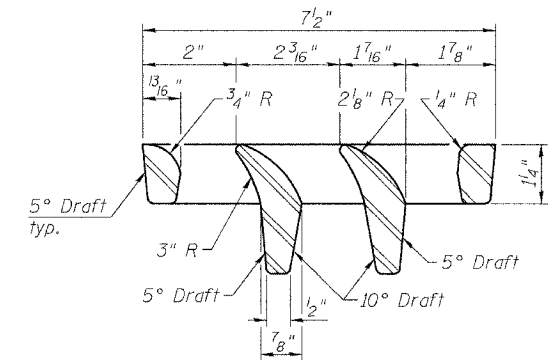
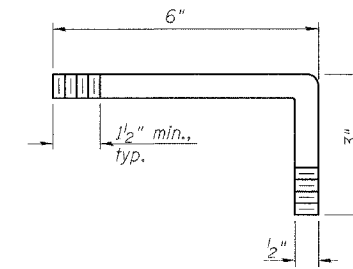
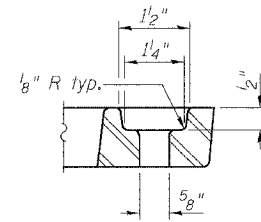
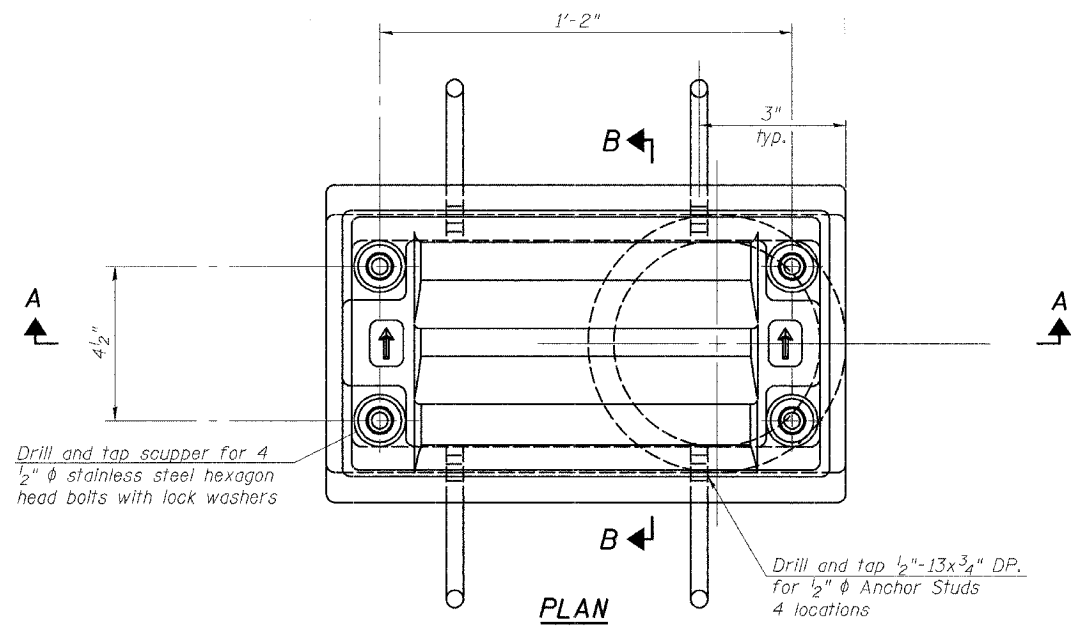

Notes: All cast iron parts shall be gray iron conforming to the requirements of AASHTO M 105, Class 35B.
Bolts, anchor studs, washers and nuts shall conform to the requirements of ASTM A 307 and shall be galvanized according to AASHTO M 232.
The grate, frame and downspout shall be galvanized according to AASHTO M 111 and ASTM A 385. Downspouts located on the exterior side of a painted steel fascia beam shall be painted with the finish coat specified for the exterior side of the fascia beam.
As an alternate, bolts, anchor studs, washers and nuts may be stainless steel according to Article 1006.29(d) of the Standard Specifications.
Structural steel weldments of equal sections and of the same configuration may be substituted for cast iron. Fillet or full penetration welds shall be used for the weldments. Details shall be submitted to the Engineer for approval.
The Contractor shall take appropriate measures to assure that Protective Coat is not applied to the scupper.
Cost of the Grate, Frame, Downspout, Anchor Studs, Bolts, Washers and Nuts including complete installation of the scupper shall be paid for at the contract unit price each for Drainage Scupper, DS-11.

BILL OF MATERIAL

ITEM	UNIT	QUANTITY
Drainage Scupper, DS-11	Each	4

STEEL DRAINAGE SCUPPER

MOFFETT ROAD OVER
DRAINAGE RAVINE
FAU 2758
LAKE COUNTY
S.N. 049-6803

TYLIN INTERNATIONAL

DESIGNED	- SP
CHECKED	- SP
DRAWN	- SP
CHECKED	-

DATE: 02-23-2005

STATE OF ILLINOIS
DEPARTMENT OF TRANSPORTATION

ROUTE NO.	SECTION	COUNTY	TOTAL SHEETS	SHEET NO.	SHEET NO. - 10
2758	*	LAKE	40	20	30 - SHEETS
FED. ROAD DIST. NO.	ILLINOIS	FED. AID PROJECT	CONTRACT 83790		
* 02-00025-00-BR					

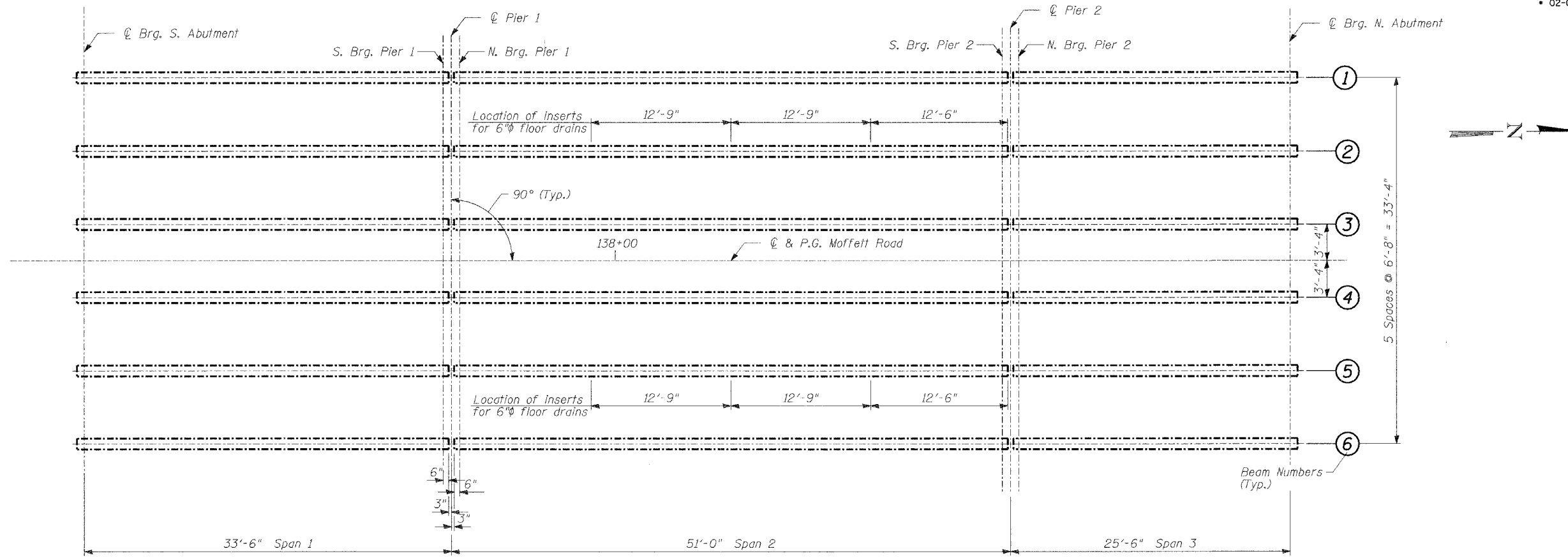

PLAN

		0.4 Sp. #1	Pier 1	0.5 Sp. #2	Pier 2	0.6 Sp. #3
I	(in ⁴)	48,648		48,648		48,648
I'	(in ⁴)	167,637		167,637		167,637
S_b	(in ³)	3,165		3,165		3,165
S_b'	(in ³)	5,850		5,850		5,850
S_t	(in ³)	2,358		2,358		2,358
S_t'	(in ³)	24,556		24,556		24,556
D	(k/')	1.02		1.02		1.02
M_D	(k)	137		332		80
s_D	(k/')	0.70	0.70	0.70	0.70	0.70
M_{sD}	(k)	39	137	97	123	5
M_L	(k)	170	161	223	186	114
M (Imp)	(k)	51	47	62	56	34

		S. Abut.	Pier 1 Span 1	Pier 1 Span 2	Pier 2 Span 2	Pier 2 Span 3	N. Abut.
R_D	(k)	17.1	17.1	26.0	26.0	13.0	13.0
R_{sD}	(k)	7.6	17.0	17.0	15.6	15.6	4.1
R_L	(k)	29.9	20.2	20.2	20.6	20.6	26.7
Imp.	(k)	8.9	4.8	4.8	5.1	5.1	8.0
R (Total)	(k)	63.5	59.1	68.0	67.3	54.3	51.8

I and I' are the moment of inertia and composite moment of inertia of the beam section.
 S_b and S_b' are the non-composite and composite section modulus for the bottom fiber of the prestressed beam.
 S_t and S_t' are the non-composite and composite section modulus for the top fiber of the prestressed beam.

NOTES:
See Sheets 11 to 13 for Beam details.

TYLIN INTERNATIONAL

DESIGNED	- DE
CHECKED	- SP
DRAWN	- DE
CHECKED	- PF

DATE: 01-28-2005

FRAMING PLAN

MOFFETT ROAD OVER
DRAINAGE RAVINE
FAU 2758
LAKE COUNTY
S.N. 049-6803

STATE OF ILLINOIS
DEPARTMENT OF TRANSPORTATION

ROUTE NO.	SECTION	COUNTY	TOTAL SHEETS	SHEET NO.	SHEET NO. - 11
2758	*	LAKE	40	21	30 - SHEETS
FED. ROAD DIST. NO.	ILLINOIS	FED. AID PROJECT	CONTRACT 83790		

• 02-00025-00-BR

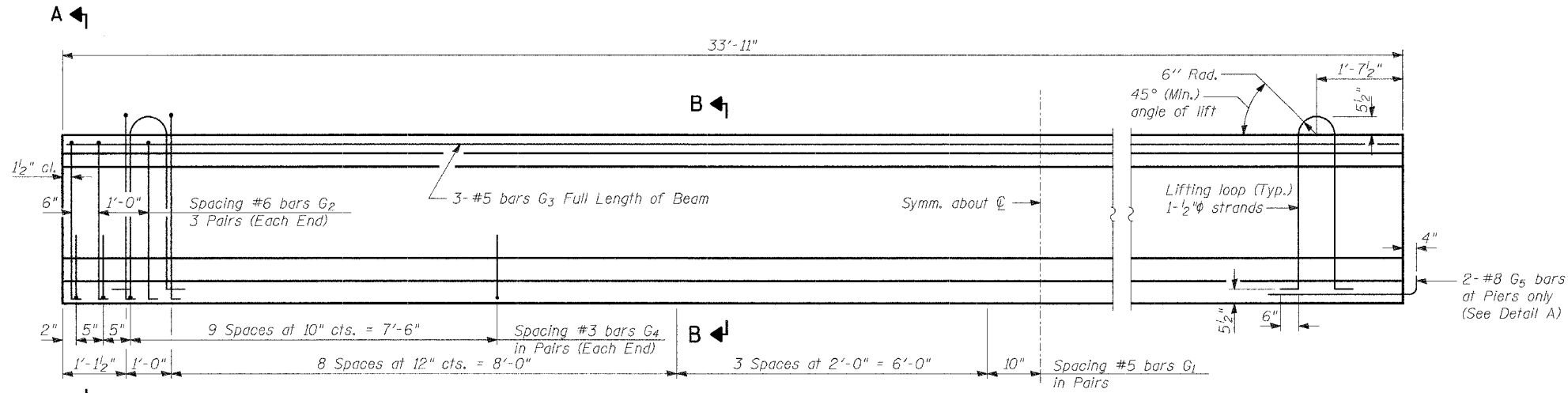

ELEVATION OF BEAM
(Showing Reinforcement & Dimensions)

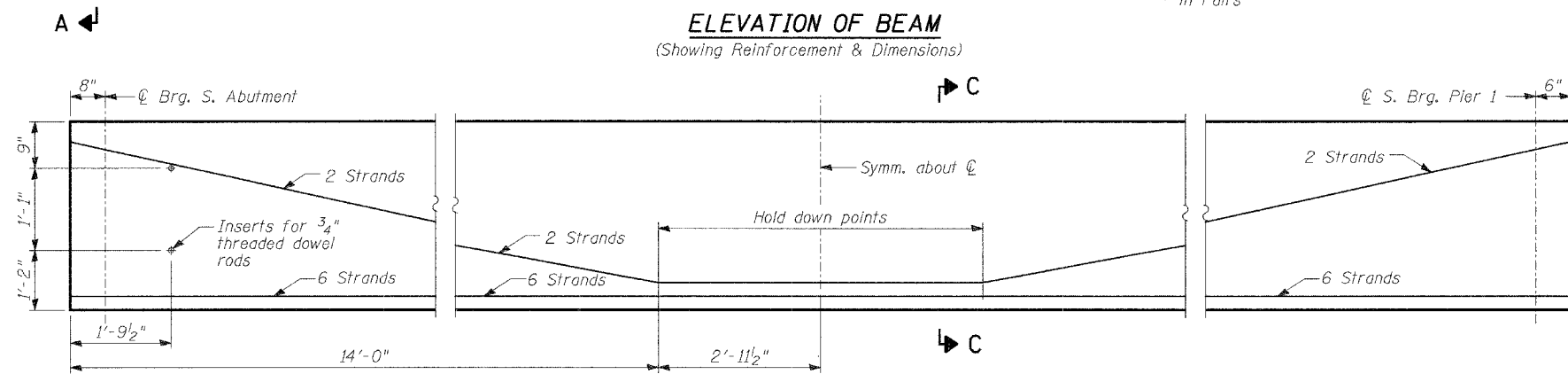

ELEVATION OF BEAM
(Showing Prestressing Steel)

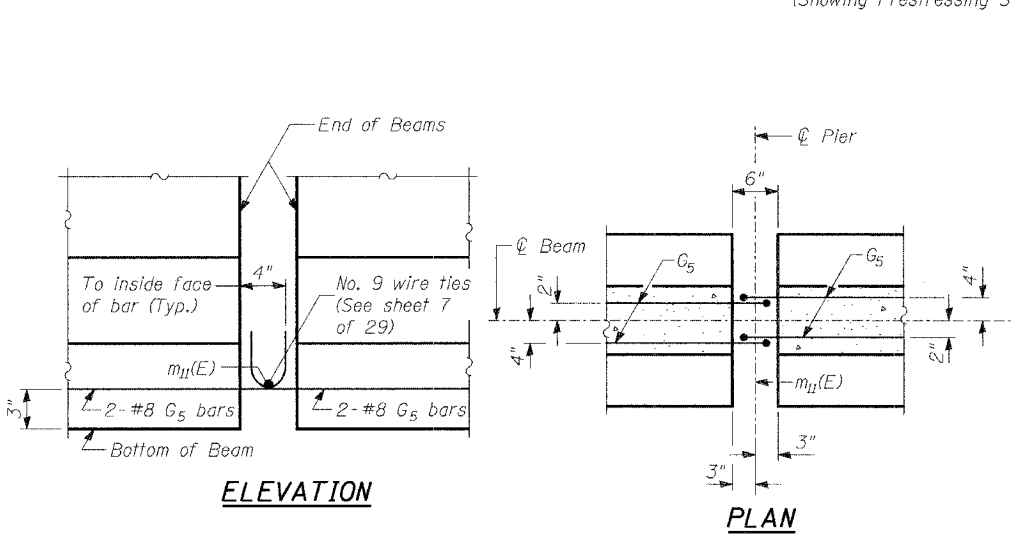

DETAIL "A"

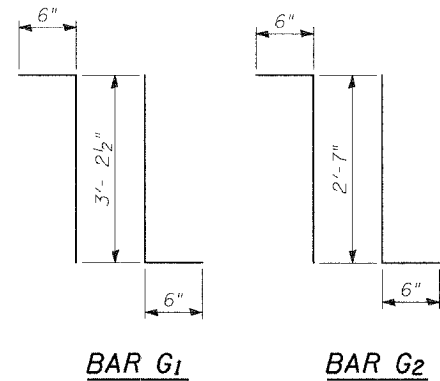

NOTES

- All inserts and threaded dowel rods for inserts, reinforcing and Prestressing Steel, and other items which are cast into the Precast Concrete I-Beams shall be included in the contract unit price per foot of "Furnishing and Erecting Precast Prestressed Concrete I-Beams, 36 in."
- Inserts for 3/4" threaded dowel rods are to be two strut, coil type for interior I-Beams and single coil, flared loop type for exterior I-Beams.
- Prestressing steel shall be uncoated high strength, low relaxation 7-wire strand, Grade 270.
- The nominal diameter shall be 1/2" and the nominal cross-sectional area shall be 0.153 sq. in.
- Non-prestressing steel shall conform to AASHTO designation M-31, M-42 or M-53 Grade 60.
- Lifting loops shall be 1 - 1/2" - 270 ksi strand, as shown.
- Required release strength, f'ci, shall be 5,000 psi.
- Reinforcement bars designated (E) shall be epoxy coated.

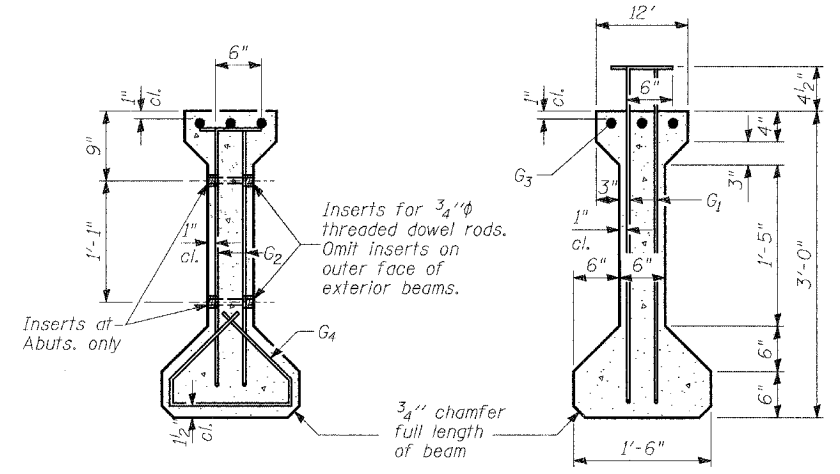

SECTION A-A

SECTION B-B

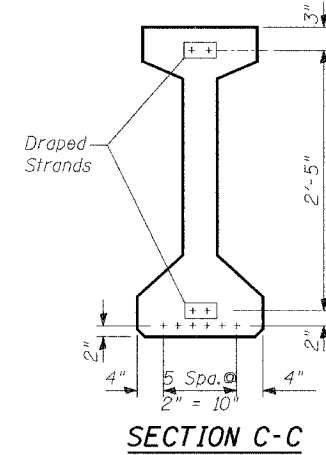

SECTION C-C

**** BAR LIST**

Bar	No.	Size	Length	Shape
G1	52	#5	4'-2 1/2"	TL
G2	12	#6	3'-7"	TL
G3	3	#5	33'-7"	—
G4	48	#3	2'-7"	—
G5	2	#8	3'-6"	—

** For one beam only.

BILL OF MATERIAL

Item	Unit	Total
Furnishing and Erecting Precast Prestressed Concrete I-Beams, 36"	Ft.	203'-6"

BEAM DETAILS - SPAN 1

MOFFETT ROAD OVER
DRAINAGE RAVINE
FAU 2758
LAKE COUNTY
S.N. 049-6803

TYLIN INTERNATIONAL

DESIGNED	- DE
CHECKED	- SP
DRAWN	- DE
CHECKED	- PF

DATE: 01-28-2005

STATE OF ILLINOIS
DEPARTMENT OF TRANSPORTATION

ROUTE NO.	SECTION	COUNTY	TOTAL SHEETS	SHEET NO.	SHEET NO. - 12
2758	*	LAKE	40	22	30 - SHEETS
FED. ROAD DIST. NO.	ILLINOIS	FED. AID PROJECT	CONTRACT 83790		

* 02-00025-00-BR

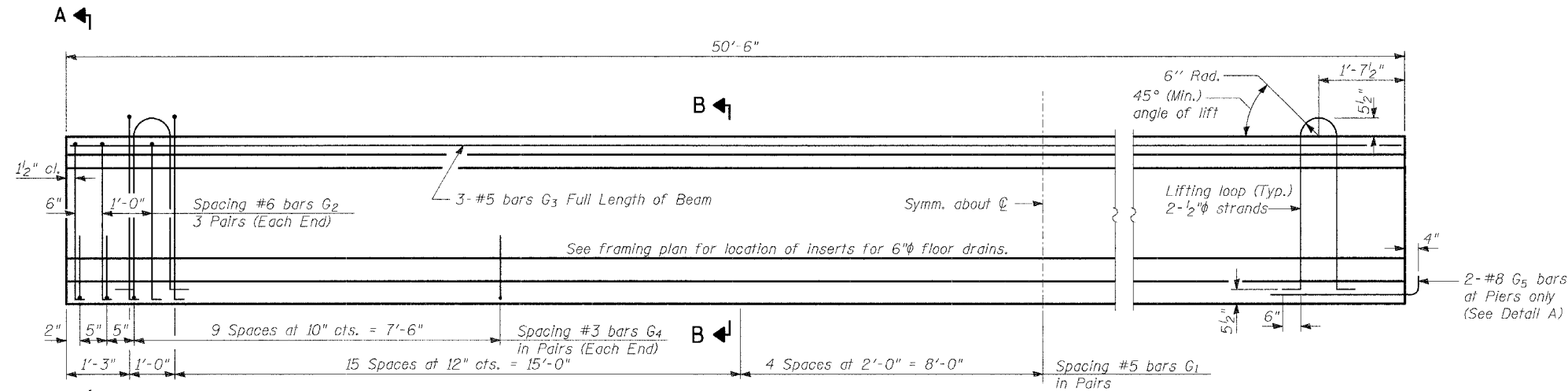

ELEVATION OF BEAM
(Showing Reinforcement & Dimensions)

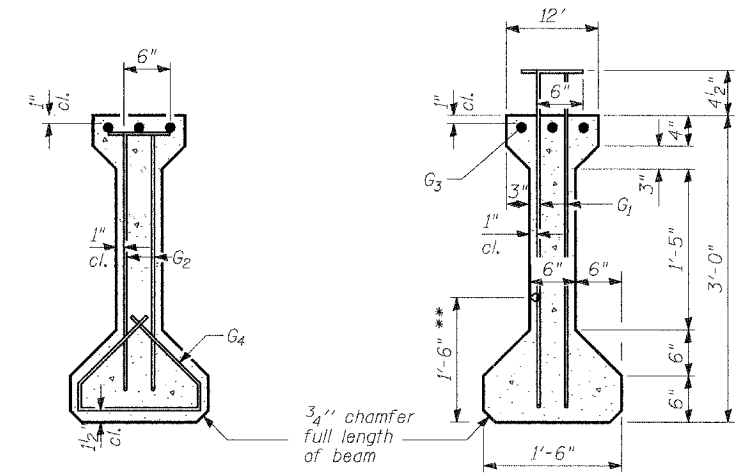

SECTION A-A

SECTION B-B

** Location of insert for 6" floor drain. For additional details see sht 6 of 30.

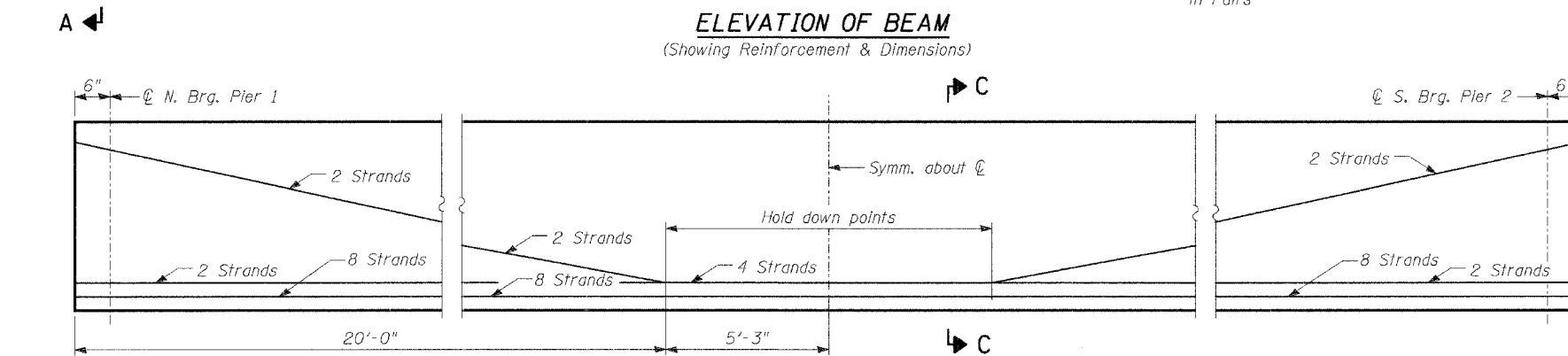

ELEVATION OF BEAM
(Showing Prestressing Steel)

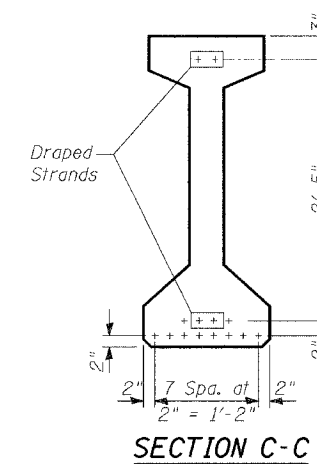

SECTION C-C

*** BAR LIST (1)**

Bar	No.	Size	Length	Shape
G1	82	#5	4'-2 1/2"	┐┌
G2	12	#6	3'-7"	┐┌
G3	3	#5	50'-2"	—
G4	48	#3	2'-7"	└┘
G5	4	#8	3'-6"	└┘

(1) For one beam only.

BILL OF MATERIAL

Item	Unit	Total
Furnishing and Erecting Precast Prestressed Concrete I-Beams, 36"	Ft.	303'-0"

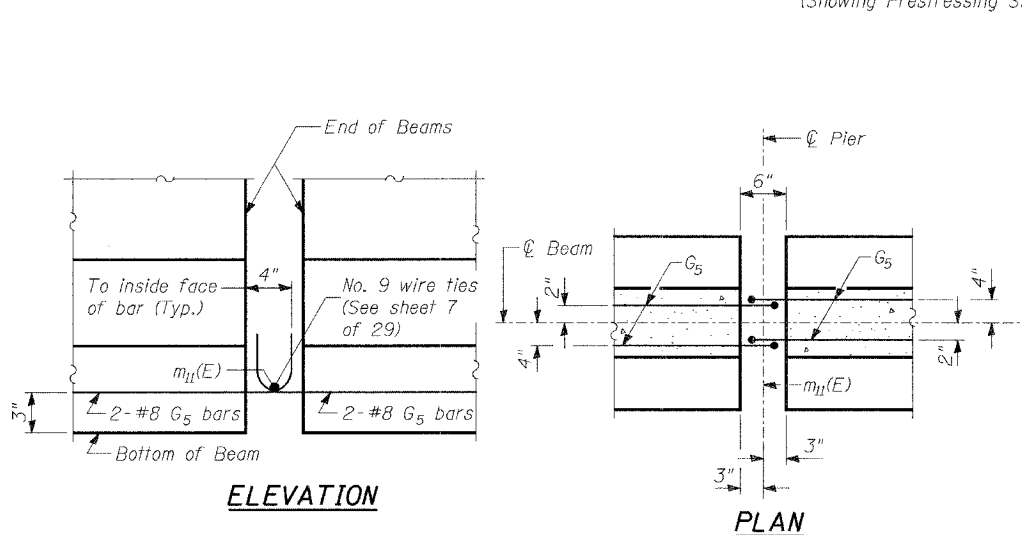

ELEVATION

PLAN

DETAIL "A"

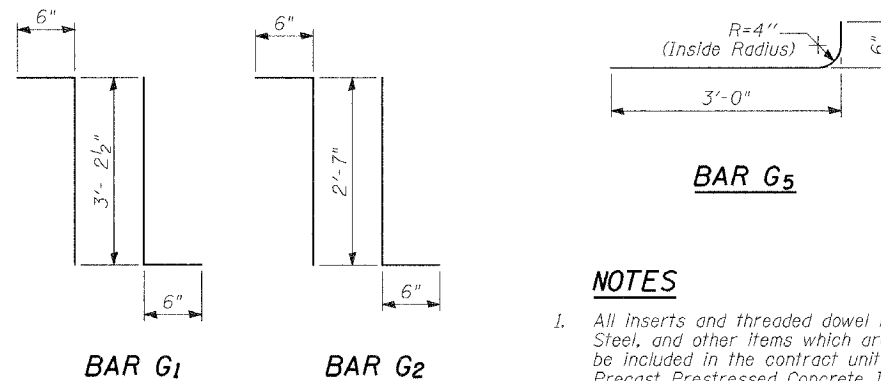

BAR G1

BAR G2

BAR G4

NOTES

- All inserts and threaded dowel rods for inserts, reinforcing and Prestressing Steel, and other items which are cast into the Precast Concrete I-Beams shall be included in the contract unit price per foot of "Furnishing and Erecting Precast Prestressed Concrete I-Beams, 36 in."
- Inserts for 3/4" threaded dowel rods are to be two strut, coil type for interior I-Beams and single coil, flared loop type for exterior I-Beams.
- Prestressing steel shall be uncoated high strength, low relaxation 7-wire strand, Grade 270.
- The nominal diameter shall be 1/2" and the nominal cross-sectional area shall be 0.153 sq. in.
- Non-prestressing steel shall conform to AASHTO designation M-31, M-42 or M-53 Grade 60.
- Lifting loops shall be 2 - 1/2" - 270 ksi strand, as shown.
- Required release strength, f'ci, shall be 5,000 psi.
- Reinforcement bars designated (E) shall be epoxy coated.

BEAM DETAILS - SPAN 2

MOFFETT ROAD OVER
DRAINAGE RAVINE
FAU 2758
LAKE COUNTY
S.N. 049-6803

TYLIN INTERNATIONAL

DESIGNED	- DE
CHECKED	- SP
DRAWN	- DE
CHECKED	- PF

DATE: 01-28-2005

STATE OF ILLINOIS
DEPARTMENT OF TRANSPORTATION

ROUTE NO.	SECTION	COUNTY	TOTAL SHEETS	SHEET	SHEET NO. - 13
2758	*	LAKE	40	23	30 - SHEETS
FED. ROAD DIST. NO.	ILLINOIS	FED. AID PROJECT	CONTRACT 83790		

* 02-00025-00-BR

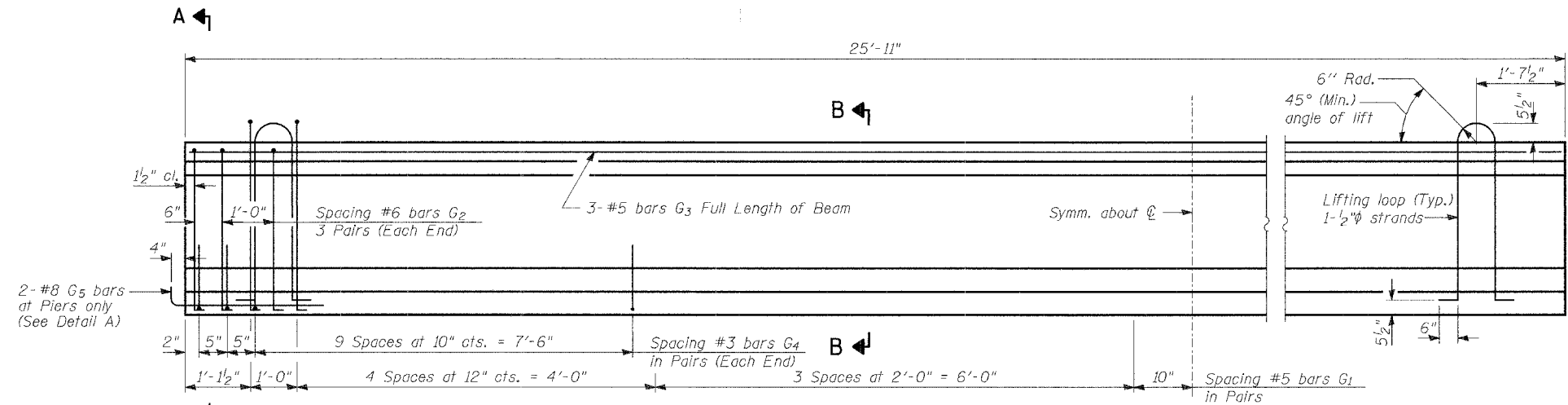

ELEVATION OF BEAM
(Showing Reinforcement & Dimensions)

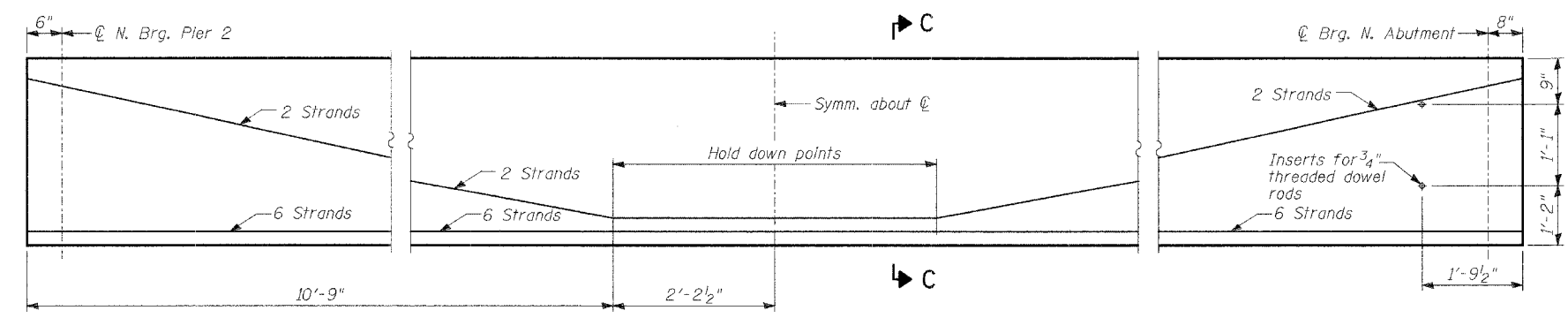

ELEVATION OF BEAM
(Showing Prestressing Steel)

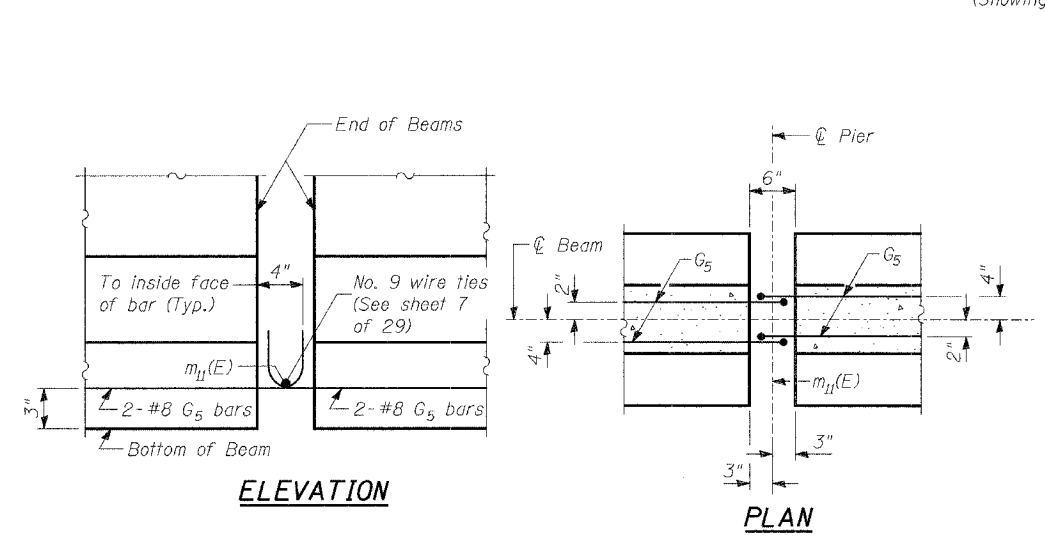

DETAIL "A"

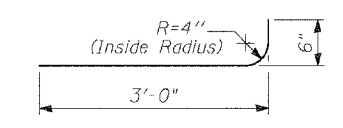
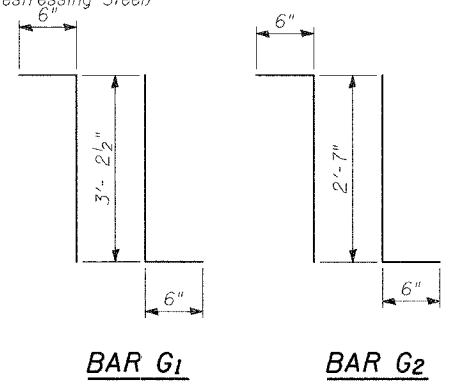

BAR G5

NOTES

- All inserts and threaded dowel rods for inserts, reinforcing and Prestressing Steel, and other items which are cast into the Precast Concrete I-Beams shall be included in the contract unit price per foot of "Furnishing and Erecting Precast Prestressed Concrete I-Beams, 36 in."
- Inserts for 3/4" threaded dowel rods are to be two strut, coil type for interior I-Beams and single coil, flared loop type for exterior I-Beams.
- Prestressing steel shall be uncoated high strength, low relaxation 7-wire strand, Grade 270.
- The nominal diameter shall be 1/2" and the nominal cross-sectional area shall be 0.153 sq. in.
- Non-prestressing steel shall conform to AASHTO designation M-31, M-42 or M-53 Grade 60.
- Lifting loops shall be 1-1/2" - 270 ksi strands, as shown.
- Required release strength, f'cl, shall be 5,000 psi.
- Reinforcement bars designated (E) shall be epoxy coated.

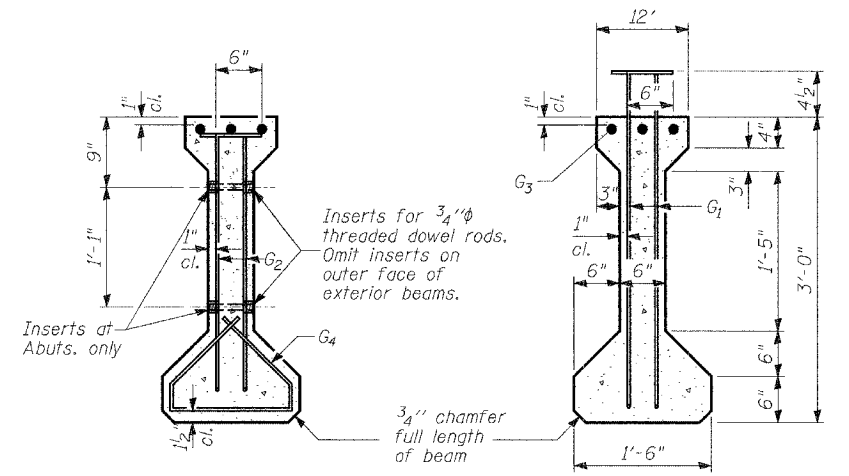

SECTION A-A

SECTION B-B

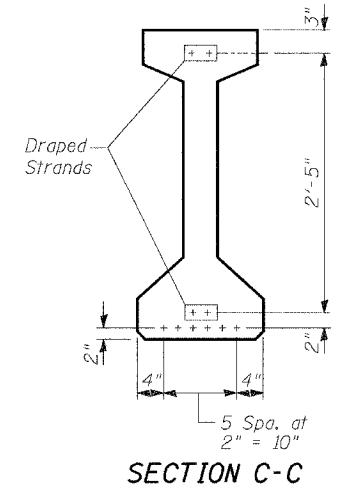

SECTION C-C

**** BAR LIST**

Bar	No.	Size	Length	Shape
G1	36	#5	4'-2 1/2"	TL
G2	12	#6	3'-7"	TL
G3	3	#5	25'-7"	—
G4	48	#3	2'-7"	—
G5	2	#8	3'-6"	—

** For one beam only.

BILL OF MATERIAL

Item	Unit	Total
Furnishing and Erecting Precast Prestressed Concrete I-Beams, 36"	Ft.	155'-6"

TYLIN INTERNATIONAL

DESIGNED	- DE
CHECKED	- SP
DRAWN	- DE
CHECKED	- PF

DATE: 01-28-2005

BEAM DETAILS - SPAN 3

MOFFETT ROAD OVER
DRAINAGE RAVINE
FAU 2758
LAKE COUNTY
S.N. 049-6803

STATE OF ILLINOIS
DEPARTMENT OF TRANSPORTATION

ROUTE NO.	SECTION	COUNTY	TOTAL SHEETS	SHEET NO.	SHEET NO. -14 30 - SHEETS CONTRACT 83790
2758	*	LAKE	40	24	
FED. ROAD DIST. NO.		ILLINOIS	FED. AID PROJECT -		
* 02-00025-00-BR					

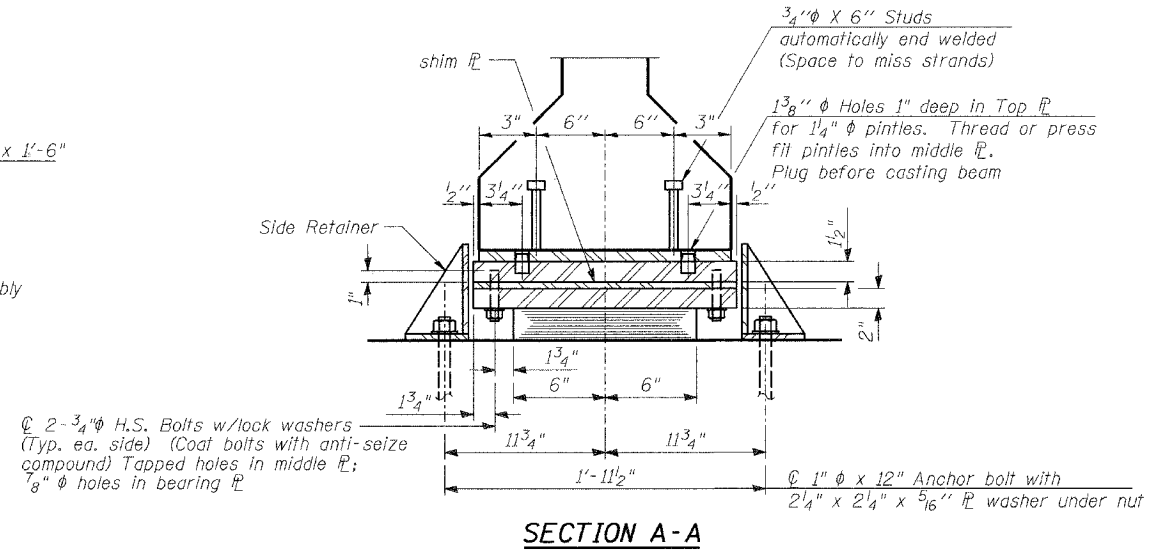
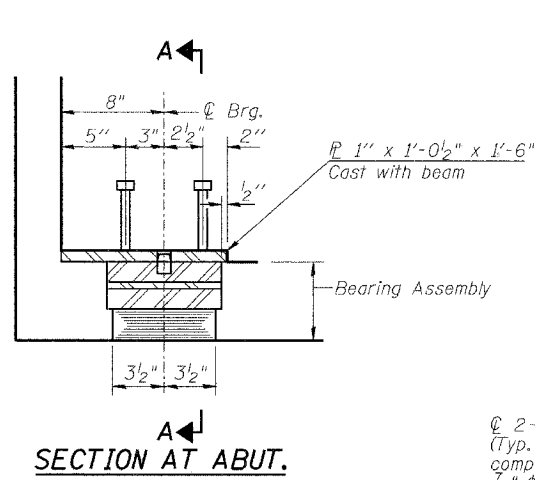

TYPE I ELASTOMERIC EXP. BRG.

Notes:
After beams have been erected holes at expansion bearings shall be drilled and anchor bolts grouted in place.
See Sheet 21 of 30 for anchor bolt installation.

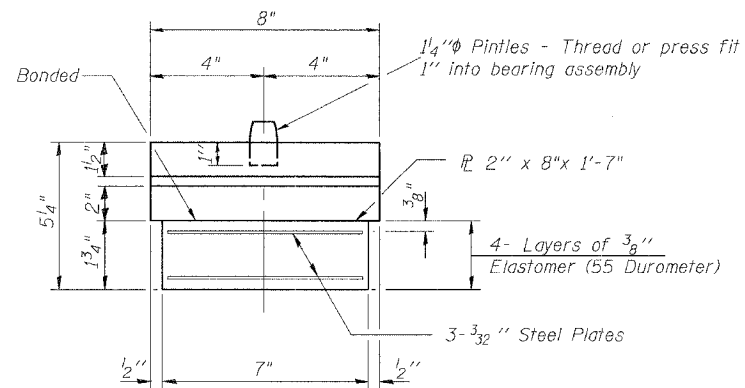

Note: Shim plates shall not be placed under Bearing Assembly.

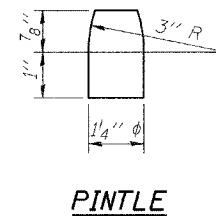

BILL OF MATERIAL

Item	Unit	Total
Elastomeric Bearing Assembly, Type I	Each	12

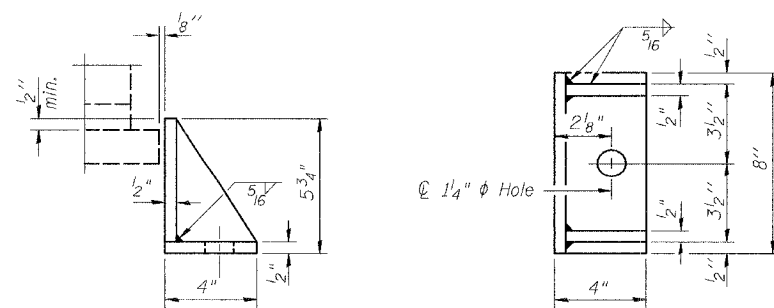

Equivalent rolled angle with stiffeners will be allowed in lieu of welded plates.

TYLIN INTERNATIONAL

DESIGNED	- DE, SP
CHECKED	- SP
DRAWN	- SP
CHECKED	- PF

DATE: 02-23-2005

BEARING DETAILS

MOFFETT ROAD OVER
DRAINAGE RAVINE
FAU 2758
LAKE COUNTY
S.N. 049-6803

STATE OF ILLINOIS
DEPARTMENT OF TRANSPORTATION

ROUTE NO.	SECTION	COUNTY	TOTAL SHEETS	SHEET NO.	SHEET NO. - 15
2758	*	LAKE	40	25	30 - SHEETS
FED. ROAD DIST. NO.	ILLINOIS	FED. AID PROJECT-			CONTRACT 83790

BILL OF MATERIAL

Bar	No.	Size	Length	Shape
n(E)	2	#5	40'-0"	
h ₁ (E)	17	#6	14'-11"	
h ₂ (E)	8	#6	11'-3 1/4"	
h ₃ (E)	4	#4	9'-2 1/4"	
h ₄ (E)	8	#4	3'-6"	
h ₅ (E)	9	#6	12'-7 1/2"	
h ₆ (E)	4	#4	10'-6 1/2"	
p(E)	16	#8	43'-4"	
p ₁ (E)	10	#5	43'-4"	
p ₂ (E)	7	#7	13'-8"	
p ₃ (E)	4	#5	12'-7"	
p ₄ (E)	5	#7	10'-0"	
p ₅ (E)	4	#5	12'-3 1/2"	
p ₆ (E)	2	#7	13'-4 1/2"	
s(E)	36	#5	14'-7"	
s ₁ (E)	15	#4	10'-11"	
s ₂ (E)	10	#4	9'-11"	
s ₃ (E)	4	#4	7'-2"	
s ₄ (E)	6	#4	10'-0 1/4"	
s ₅ (E)	41	#5	4'-0"	
v(E)	34	#5	6'-1"	
v ₁ (E)	20	#5	6'-2"	
v ₂ (E)	21	#4	4'-4"	
v ₃ (E)	8	#6	5'-2"	
v ₄ (E)	12	#6	6'-4"	
v ₄₂ (E)	27	#3	3'-8"	
u(E)	14	#6	8'-7 1/2"	
sp	3	#4	29'-6"	WWWWW
v	36	#9	32'-8"	
Concrete Structures, Special		Cu Yd	38.7	
Reinforcement Bars, Epoxy Coated		Pound	5360	
Reinforcement Bars		Pound	4845	
Structure Excavation		Cu Yd	126	
Porous Granular Embankment		Cu Yd	93	
Drilled Shaft in Soil, 36"		Foot	96	
Architectural Concrete		Cu Yd	1.6	

** Length is height of spiral.
Reinforcement bars designated (E) shall be epoxy coated.

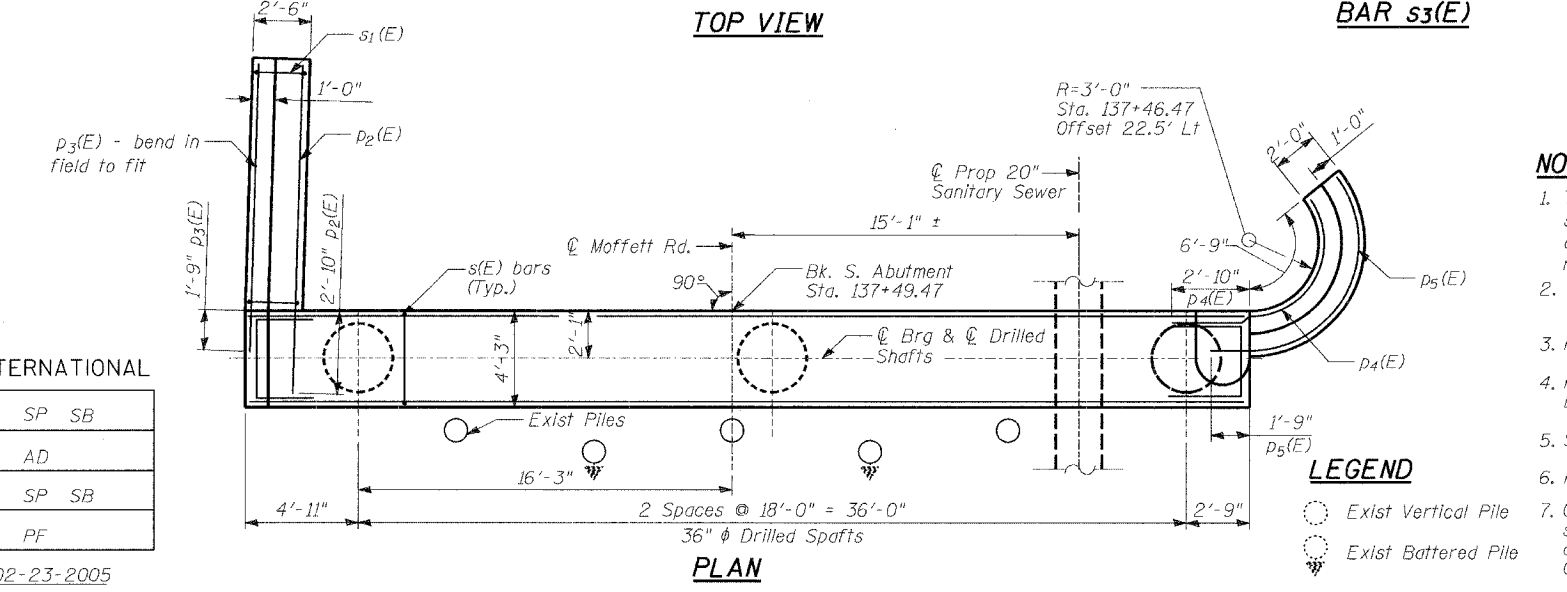
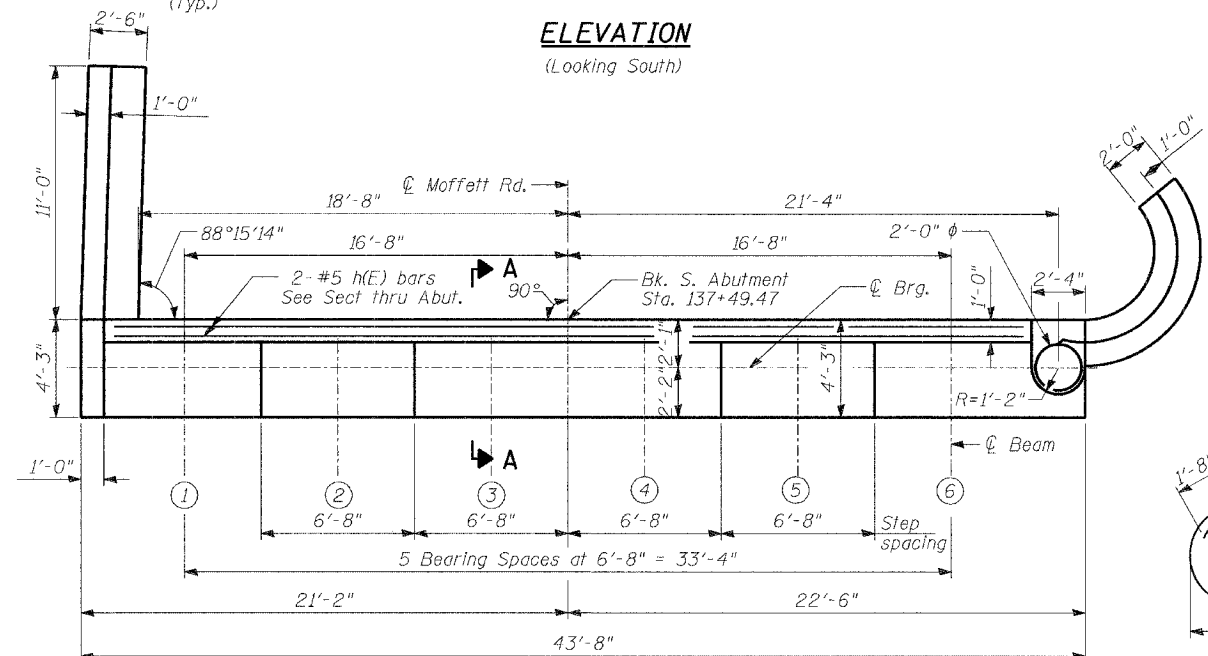
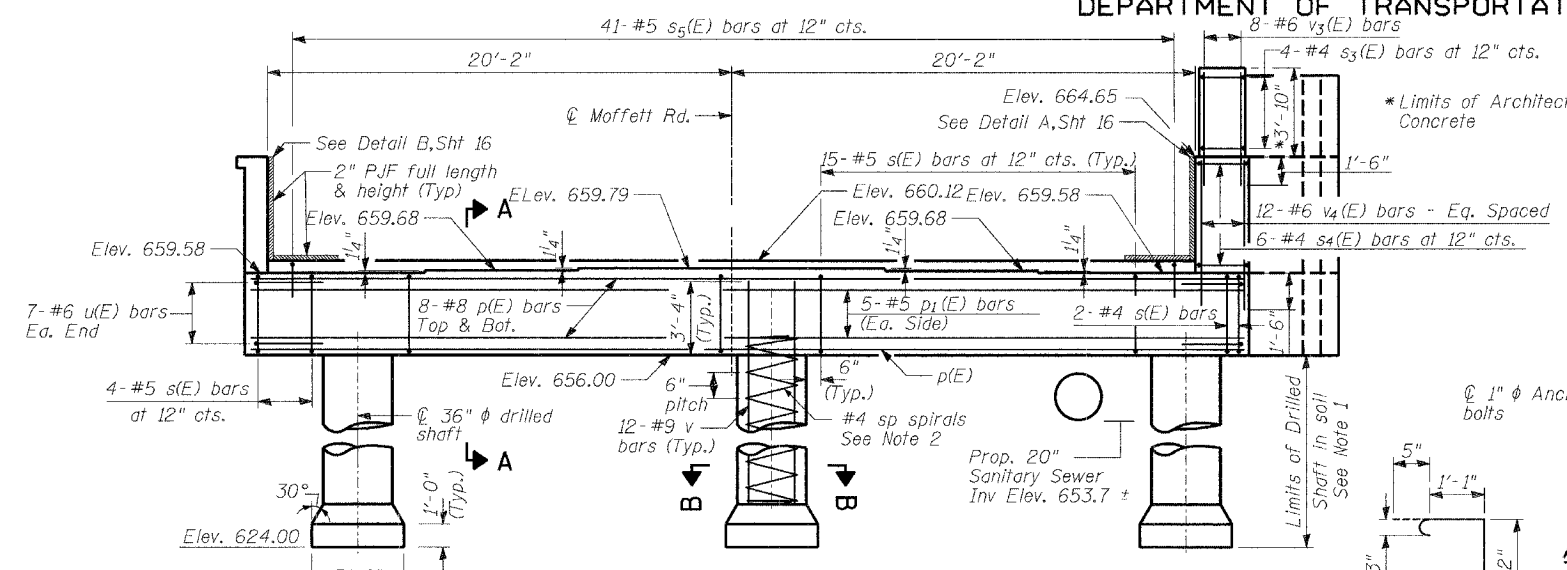

TYLIN INTERNATIONAL

DESIGNED	- SP SB
CHECKED	- AD
DRAWN	- SP SB
CHECKED	- PF

DATE: 02-23-2005

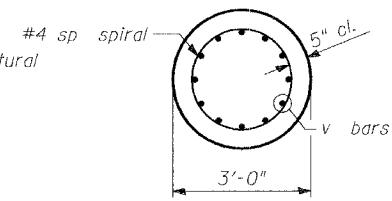

SECTION B-B

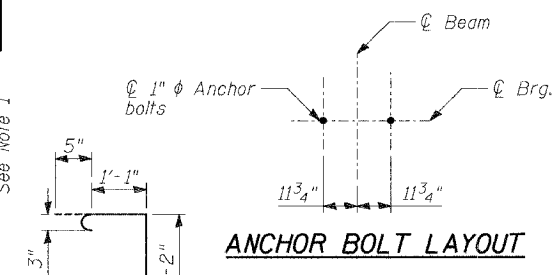

ANCHOR BOLT LAYOUT

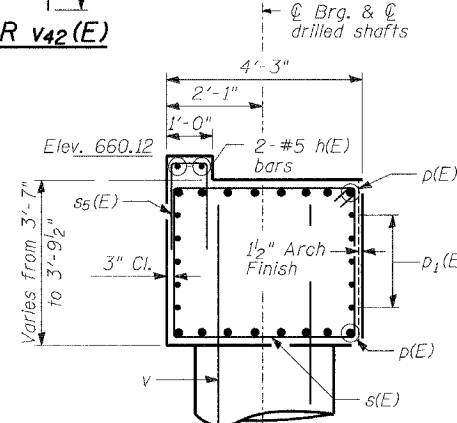

SECTION A-A

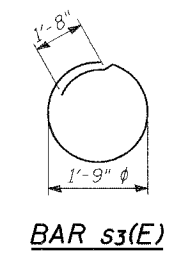

BAR s3(E)

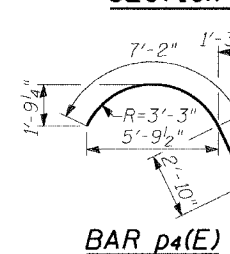

BAR p4(E)

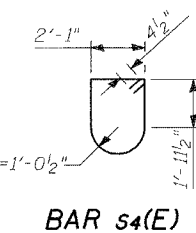

BAR s4(E)

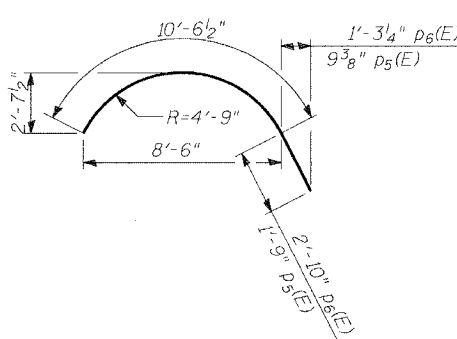

BAR h6(E), h5(E)

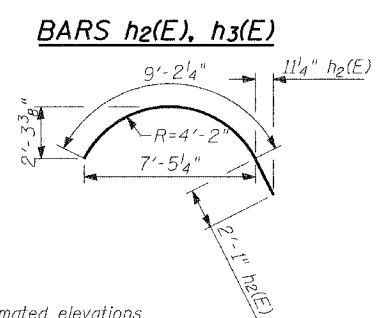

BARS h2(E), h3(E)

NOTES

- The quantities and detailing are based on the estimated elevations shown on the plans. The actual elevations may differ at each shaft and corresponding adjustments shall be made to the drilled shaft and reinforcement quantities and payment limits.
- Provide 1/2 extra turns top and bottom of each drilled shaft. Extend spiral 2" into abutment cap. Provide min. 4-#4 spacers or equivalent.
- Min. lap for spirals = 1'-8".
- Provide Temporary casing to Elev. 631, included in the cost for Drilled Shaft in Soil, 36".
- Space reinforcement in cap to miss anchor bolts.
- Pour steps monolithically with cap.
- Contractor shall be responsible for the design, installation, and subsequent removal of any temporary embankment or support system as required to provide equipment access for drilled shaft installation. Cost shall be included in the unit price for Drilled Shaft in Soil, 36".
- See Sheet 26 of 30 for Architectural Finish details.

SOUTH ABUTMENT

MOFFETT ROAD OVER
DRAINAGE RAVINE
FAU 2758
LAKE COUNTY
S.N. 049-6803

- LEGEND
- Exist Vertical Pile
 - ⊙ Exist Battered Pile

STATE OF ILLINOIS
DEPARTMENT OF TRANSPORTATION

ROUTE NO.	SECTION	COUNTY	TOTAL SHEETS	SHEET NO.	SHEET NO. - 16
2758		LAKE	40	26	30 - SHEETS
FED. ROAD DIST. NO.	ILLINOIS	FED. AID PROJECT	CONTRACT 83790		
• 02-00025-00-BR					

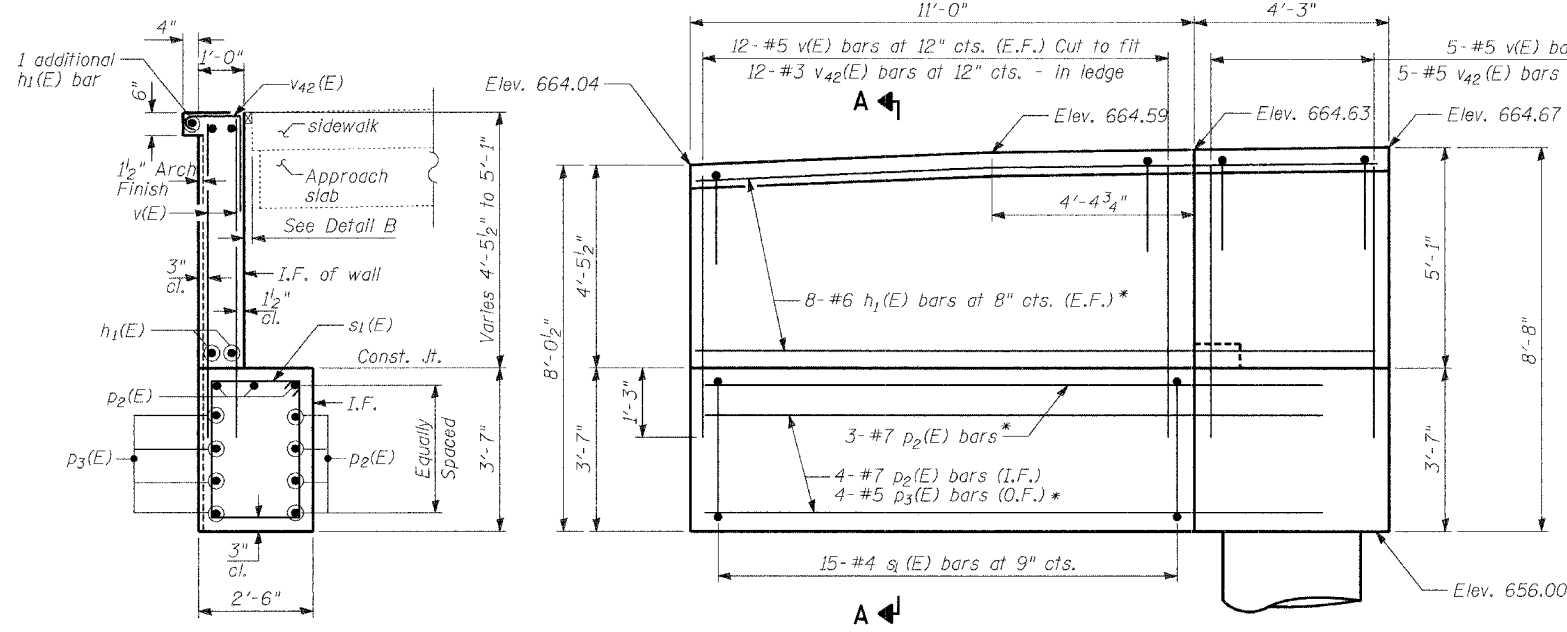

SECTION A-A

EAST WING WALL ELEVATION
(Looking West)

* Bend as needed in field

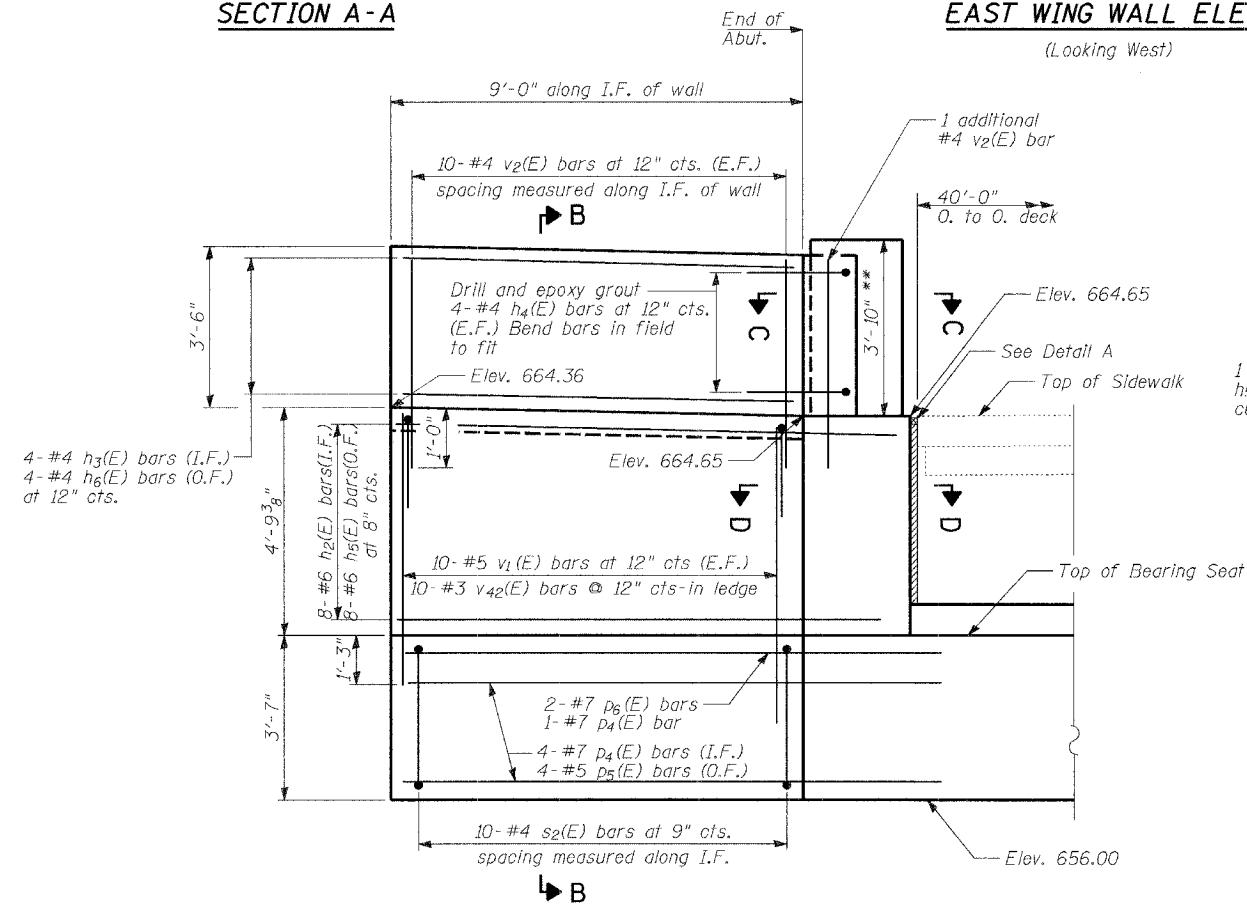

WEST WING WALL ELEVATION
(Looking Northwest)

** Limits of Architectural Concrete

TYLIN INTERNATIONAL

DESIGNED	- SP
CHECKED	- AD
DRAWN	- SP
CHECKED	- PF

DATE: 02-23-2005

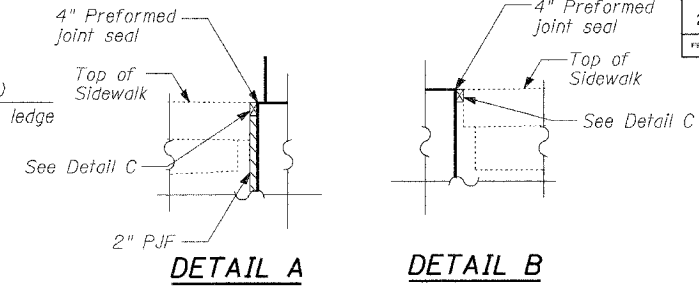

Note:
4" Preformed joint seal shall be included in the cost of Concrete Structures, Special. Installation of the Preformed joint seal shall be in accordance with 503.10d of the Standard Specifications. Material shall be in accordance with Section 1053 of the Standard Specifications

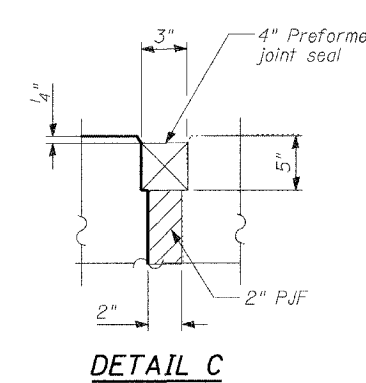

PREFORMED JOINT SEAL
NTS

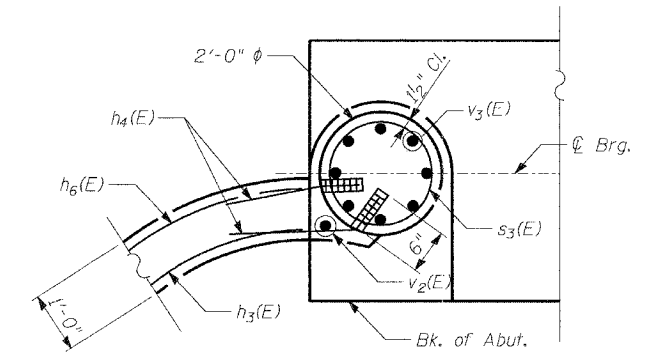

SECTION C-C

Note:
Epoxy grout bars in 6 inch deep minimum drilled holes according to Section 584 of the Standard Specifications. Cost shall be included in Concrete Structures, Special.

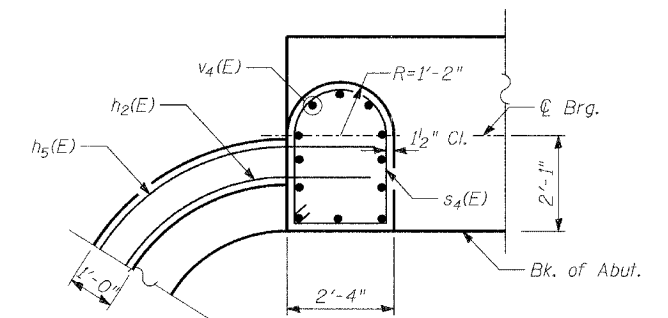

SECTION D-D

NOTES

For Architectural finish, see Sheet 26.

SOUTH ABUTMENT DETAILS

MOFFETT ROAD OVER
DRAINAGE RAVINE
FAU 2758
LAKE COUNTY
S.N. 049-6803

STATE OF ILLINOIS
DEPARTMENT OF TRANSPORTATION

ROUTE NO.	SECTION	COUNTY	TOTAL SHEETS	SHEET NO.
2758	*	LAKE	40	27
FED. ROAD DIST. NO.	SUB-DIVISION	FED. AID PROJECT	SHEET NO. - 17	
			30 SHEETS	
02-00025-00-BR			CONTRACT 83790	

BILL OF MATERIAL

Bar	No.	Size	Length	Shape
h3 (E)	4	#4	9'-2 1/4"	⌒
h4 (E)	16	#4	3'-6"	—
h6 (E)	4	#4	10'-6 1/2"	⌒
h20(E)	2	#5	40'-0"	—
h21(E)	11	#7	11'-6 1/2"	⌒
h22(E)	12	#5	12'-10"	⌒
h23(E)	11	#7	11'-5 1/4"	⌒
h24(E)	12	#5	9'-6"	⌒
h25(E)	4	#4	8'-8"	⌒
h26(E)	4	#4	10'-0 1/2"	⌒
p4 (E)	6	#7	10'-0"	⌒
p6 (E)	2	#7	13'-4 1/2"	⌒
p5 (E)	5	#7	12'-3 1/2"	⌒
p20(E)	8	#8	44'-8"	—
p21(E)	8	#8	39'-8"	—
p22(E)	8	#8	10'-6"	—
p23(E)	8	#8	9'-0"	—
p24(E)	16	#6	44'-8"	—
p25(E)	7	#7	11'-4"	⌒
p26(E)	1	#7	9'-3"	⌒
p27(E)	5	#5	8'-3 1/2"	⌒
s3(E)	8	#4	7'-2"	○
s4(E)	12	#4	10'-0 1/4"	□
s5(E)	40	#5	4'-0"	□
s20(E)	72	#5	12'-9"	□
s21(E)	20	#4	11'-5"	□
v2(E)	42	#4	4'-4"	—
v3(E)	16	#6	5'-2"	—
v20(E)	40	#5	8'-11"	—
v21(E)	24	#6	6'-5"	—
v42(E)	20	#3	3'-8"	—
u (E)	20	#6	8'-7 1/2"	—
sp30	3	#4	26'-7"	www
v20	36	#9	30'-0"	—
Concrete Structures, Special		Cu Yd	62.5	
Reinforcement Bars, Epoxy Coated		Pound	7270	
Reinforcement Bars		Pound	4450	
Structure Excavation		Cu Yd	117	
Porous Granular Embankment		Cu Yd	183	
Drilled Shaft in Soil, 36"		Foot	87.3	
Architectural Concrete		Cu Yd	3.3	

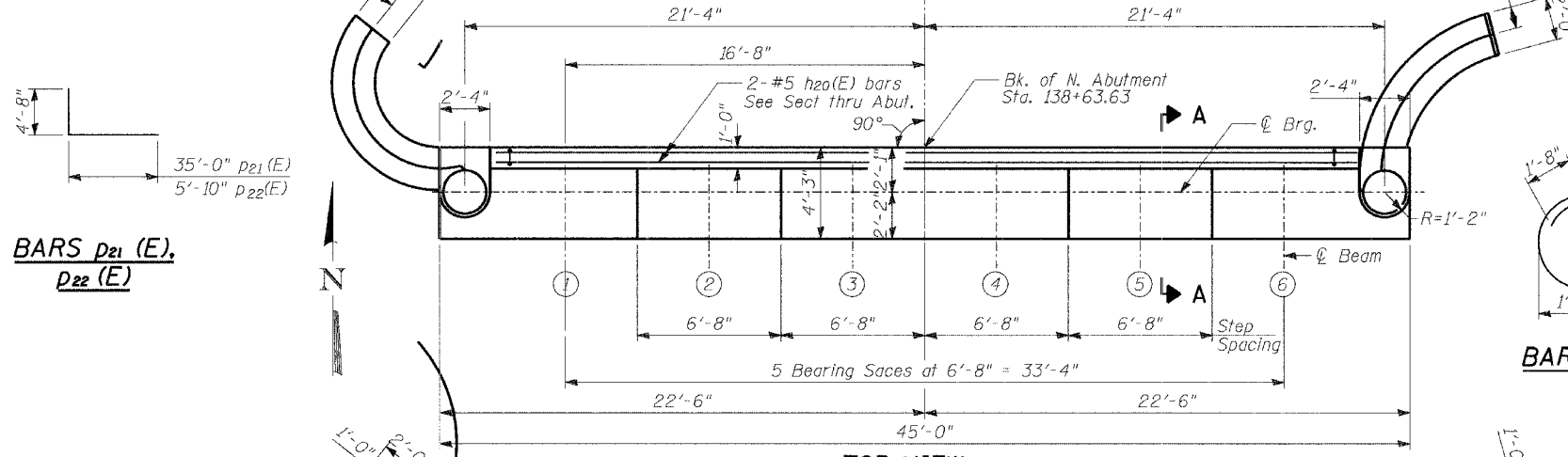
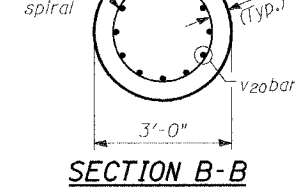
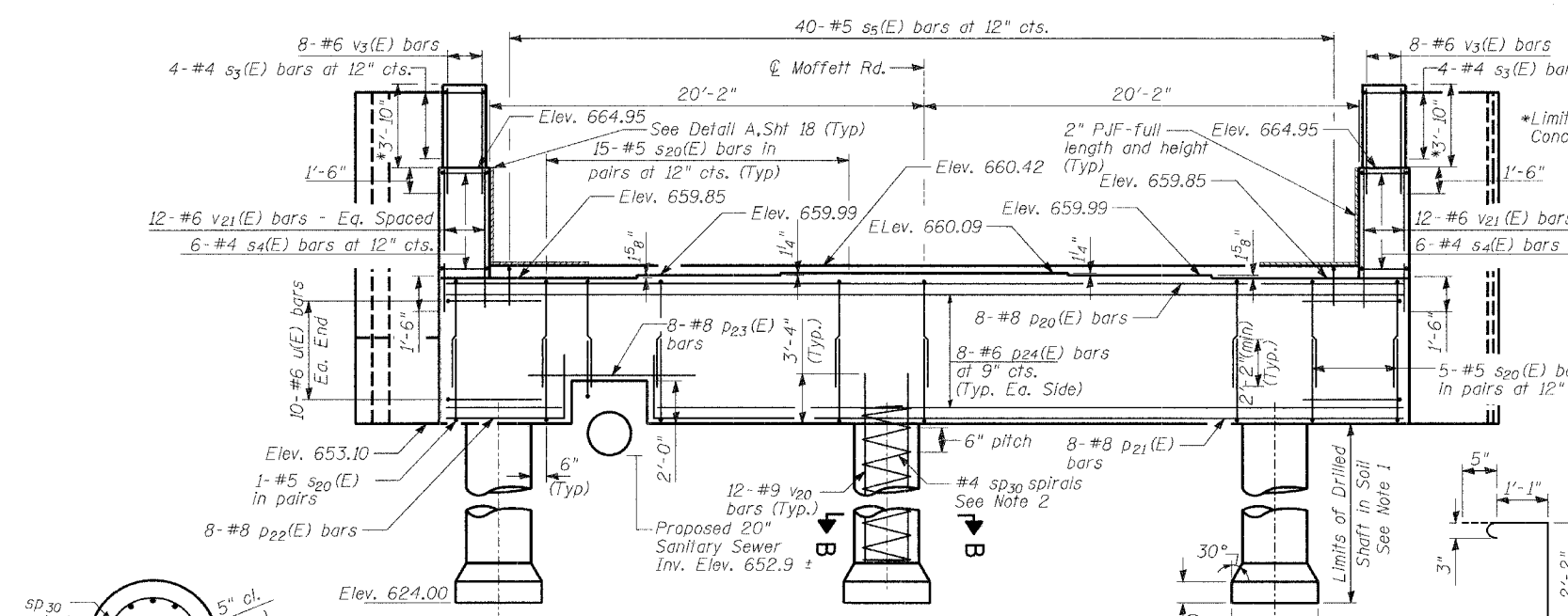

LEGEND

- Exist Vertical Pile
- Exist Battered Pile

TYLIN INTERNATIONAL

DESIGNED	- SB, SP
CHECKED	- SP, AD
DRAWN	- SB, SP
CHECKED	- PF

DATE: 02-23-2005

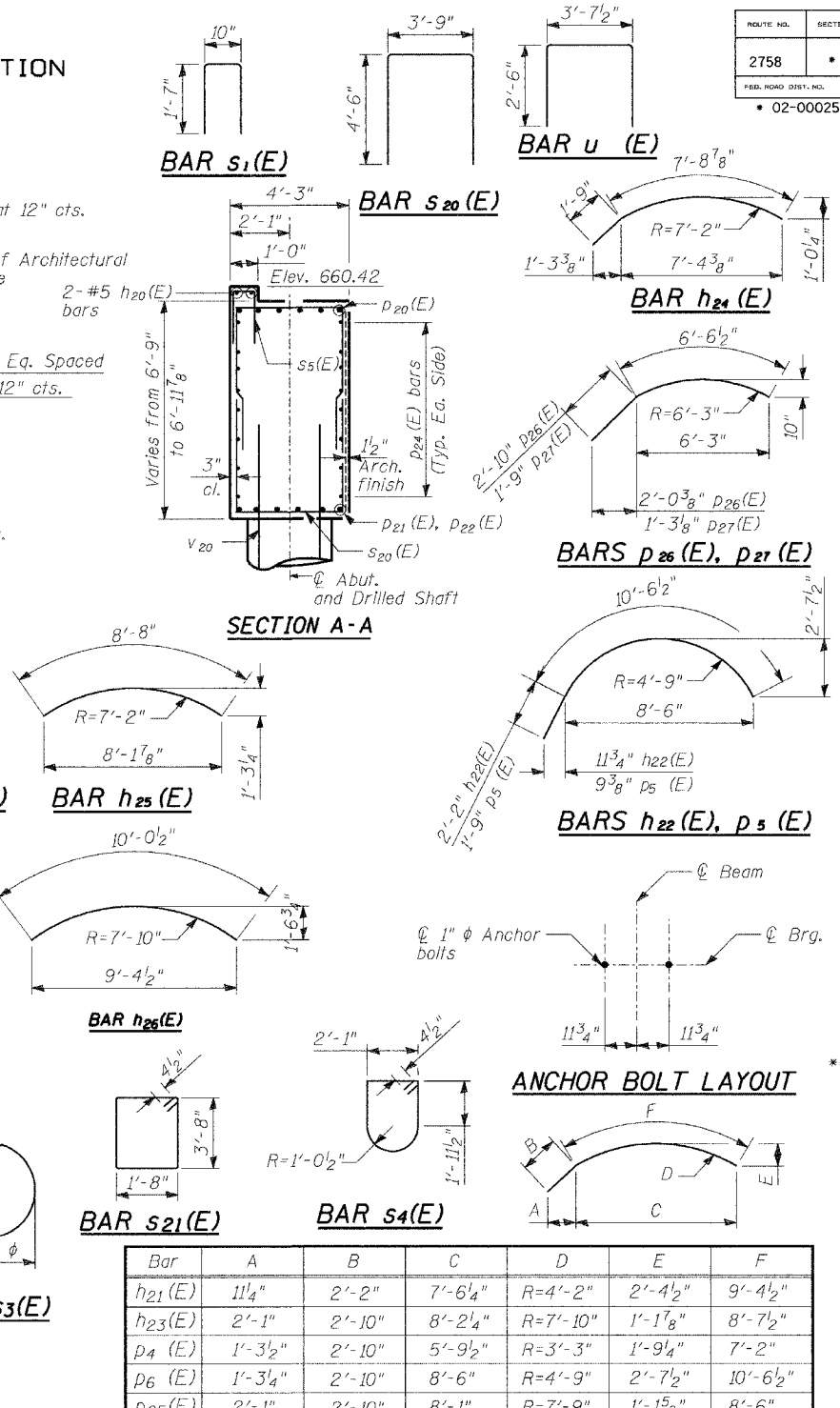

- NOTES**
- The quantities and detailing are based on the estimated elevations shown on the plans. The actual elevations may differ at each shaft and corresponding adjustments shall be made to the drilled shaft and reinforcement quantities and payment limits.
 - Provide 1/2 extra turns top and bottom of each drilled shaft. Extend spiral 2" into abutment cap. Provide min. 4-#4 spacers or equivalent.
 - Min. lap for spirals = 1'-8".
 - Provide Temporary casing to Elev. 631, included in the cost for Drilled Shaft in Soil, 36".
 - Space reinforcement in cap to miss anchor bolts.
 - Pour steps monolithically with cap.
 - Contractor shall be responsible for the design, installation, and subsequent removal of any temporary embankment or support system as required to provide equipment access for drilled shaft installation. Cost shall be included in the unit price for Drilled Shaft in Soil, 36".

NORTH ABUTMENT

MOFFETT ROAD OVER
DRAINAGE RAVINE
FAU 2758
LAKE COUNTY
S.N. 049-6803

STATE OF ILLINOIS
DEPARTMENT OF TRANSPORTATION

ROUTE NO.	SECTION	COUNTY	TOTAL SHEETS	SHEET NO.	SHEET NO. - 18
2758	*	LAKE	40	28	30 - SHEETS
FED. ROAD DIST. NO.	ILLINOIS	FED. AID PROJECT-	CONTRACT 83790		

02-00025-00-BR

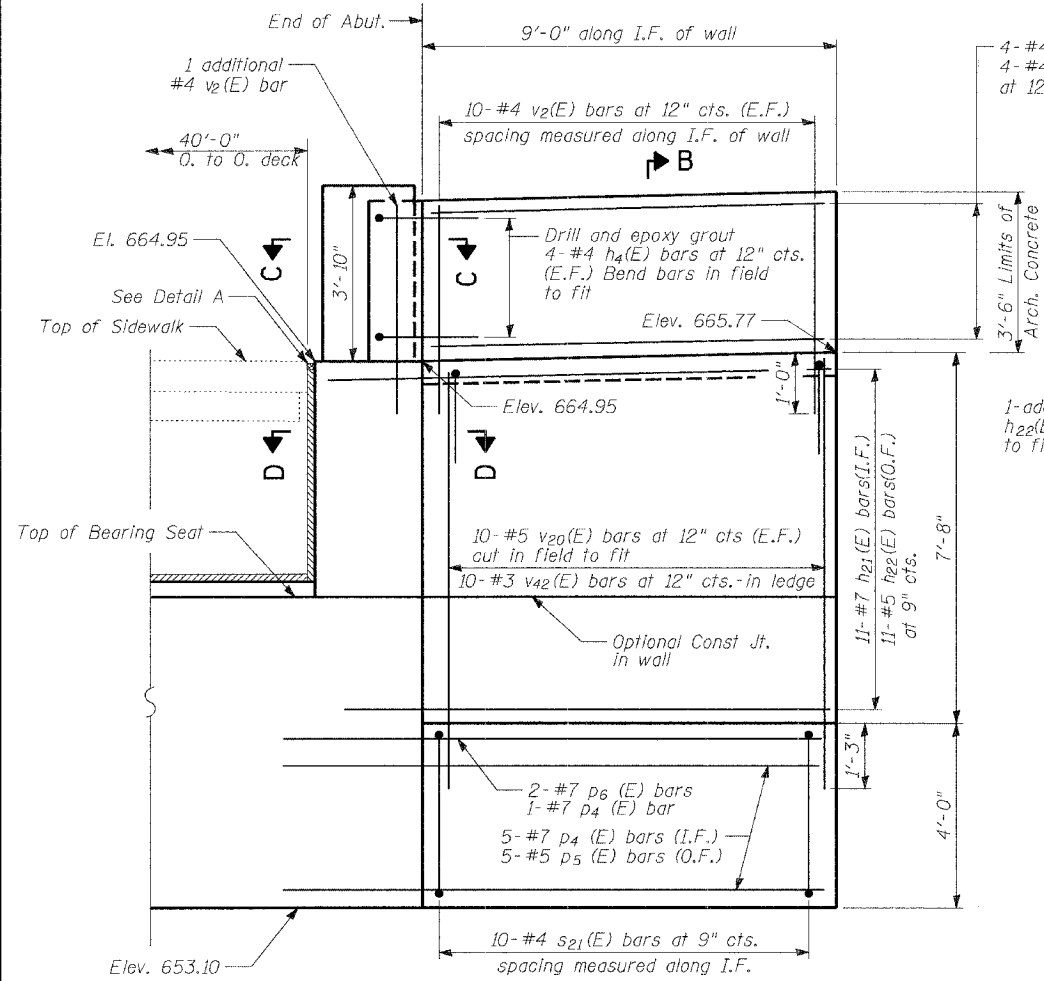

WEST WING WALL ELEVATION
(Looking Southwest)

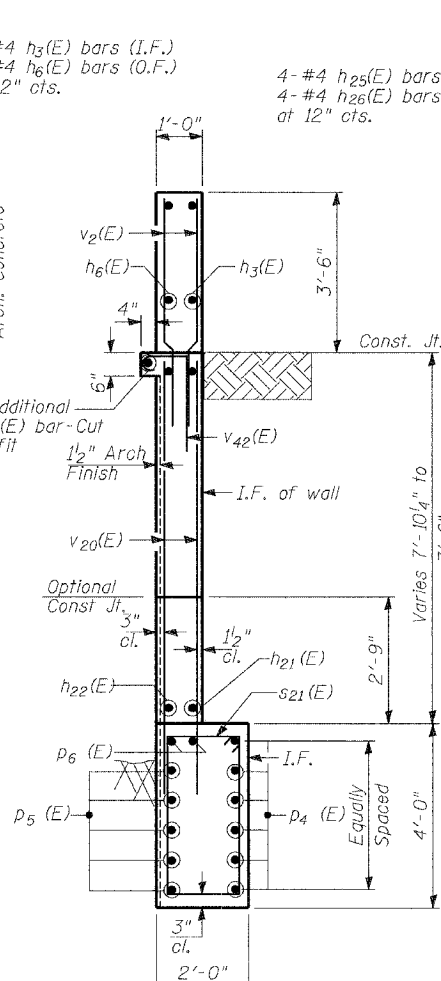

SECTION B-B

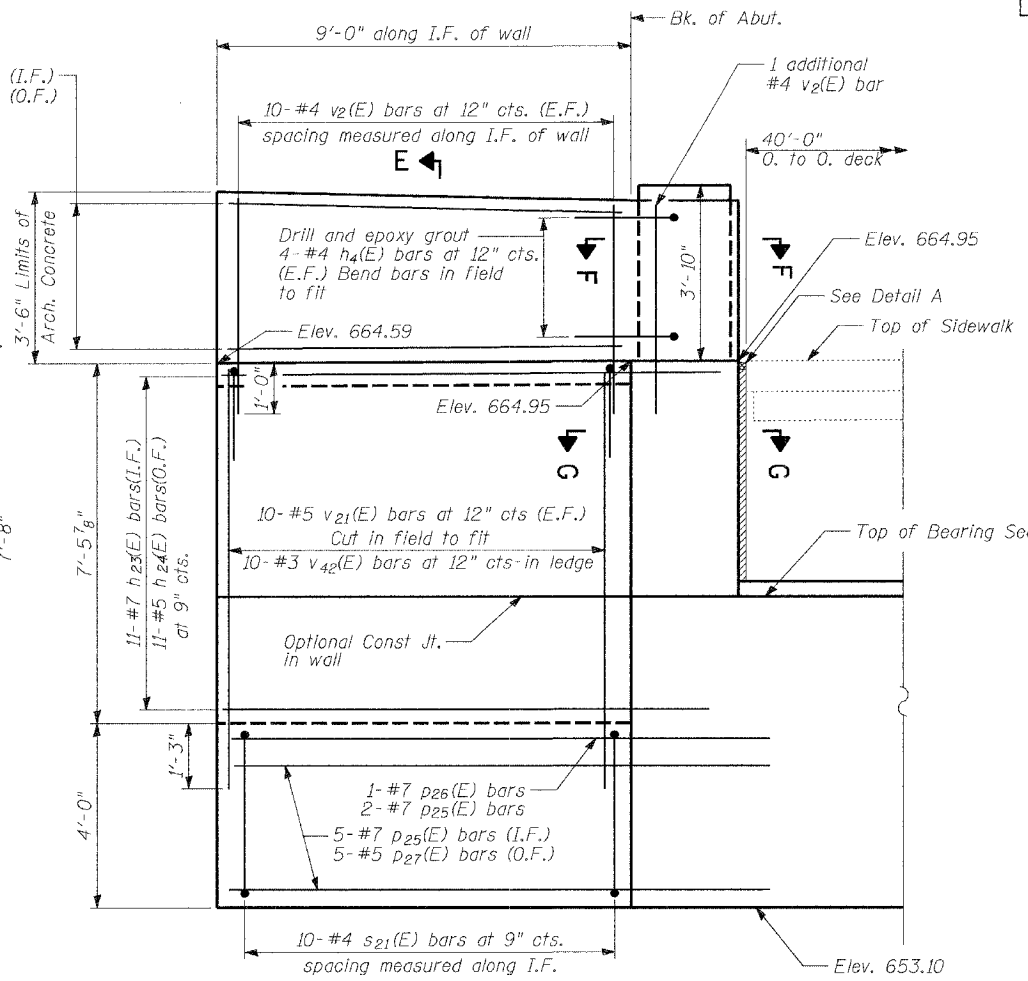

EAST WING WALL ELEVATION
(Looking Southeast)

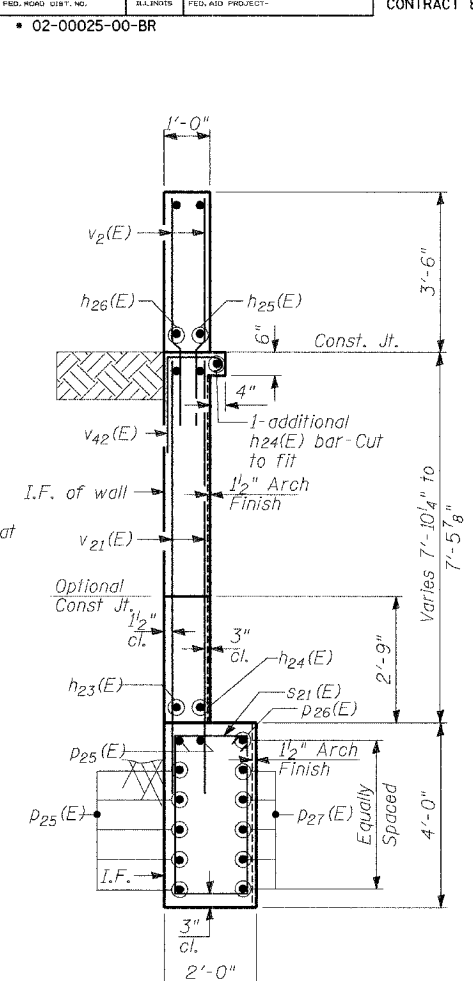

SECTION E-E

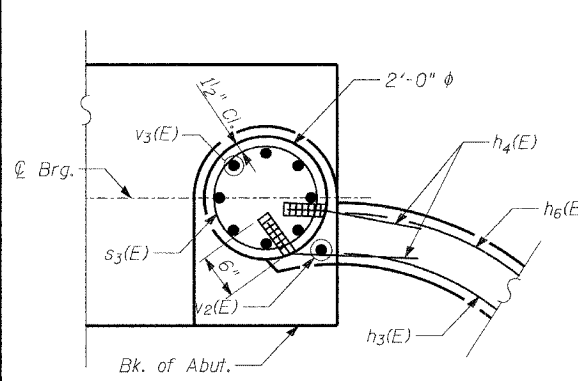

SECTION C-C

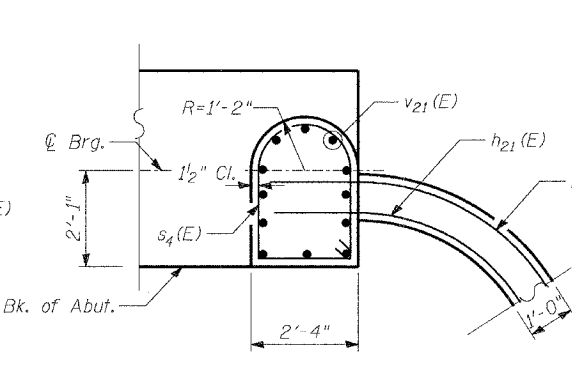

SECTION D-D

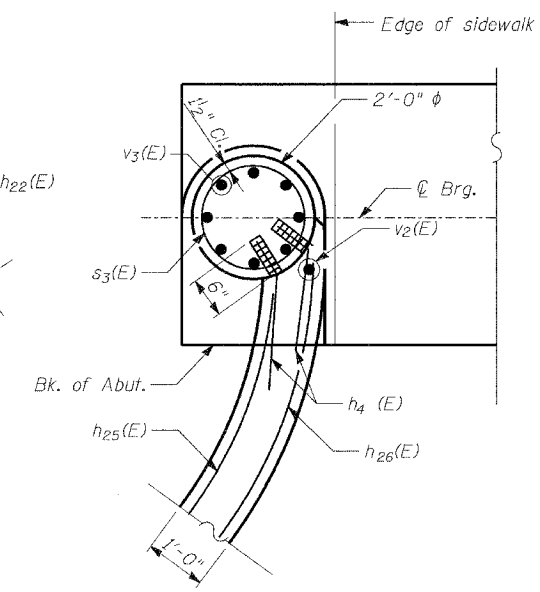

SECTION F-F

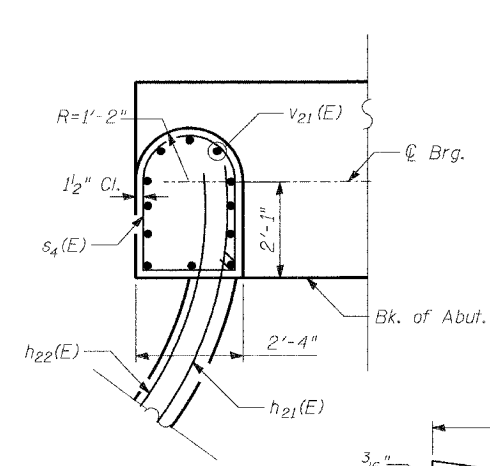

SECTION G-G

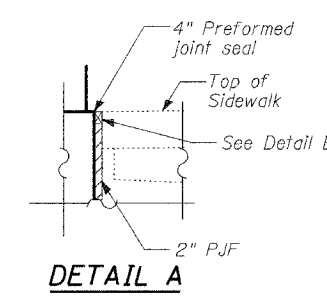

DETAIL A

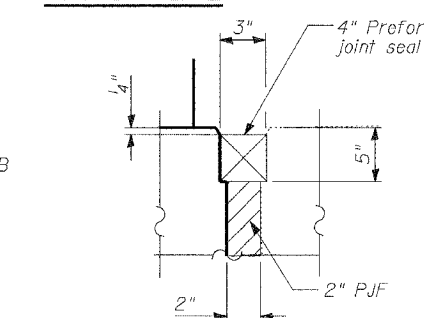

DETAIL B

Note:
4" Preformed joint seal shall be included in the cost of Concrete Structures, Special. Installation of the Preformed joint seal shall be in accordance with 503.10d of the Standard Specifications. Material shall be in accordance with Section 1053 of the Standard Specifications.

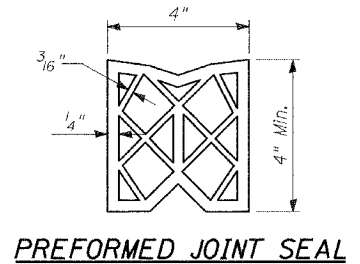

PREFORMED JOINT SEAL

NORTH ABUTMENT DETAILS

MOFFETT ROAD OVER
DRAINAGE RAVINE
FAU 2758
LAKE COUNTY
S.N. 049-6803

TYLIN INTERNATIONAL

DESIGNED	- SP
CHECKED	- AD
DRAWN	- SP
CHECKED	- PF

DATE: 02-23-2005

Note:
Epoxy grout bars in 6 inch deep minimum drilled holes according to Section 584 of the Standard Specifications. Cost shall be included in Concrete Structures, Special.

NOTES

For Architectural finish, see Sheet 26.

STATE OF ILLINOIS
DEPARTMENT OF TRANSPORTATION

ROUTE NO.	SECTION	COUNTY	TOTAL SHEETS	SHEET NO.	SHEET NO. -19
2758	*	LAKE	40	29	30 SHEETS
FED. ROAD DIST. NO.	ILLINOIS	FED. AID PROJECT	CONTRACT 83790		

02-00025-00-BR

BILL OF MATERIAL

Bar	No.	Size	Length	Shape
$h_{10}(E)$	10	#5	34'-4"	—
$p_{10}(E)$	7	#10	34'-4"	—
$p_{11}(E)$	7	#8	34'-4"	—
$s_{10}(E)$	46	#5	8'-4"	□
** sp_{10}	3	#4	19'-8"	~~~~~
** $sp_{11}(E)$	3	#4	9'-7"	~~~~~
$u_{10}(E)$	14	#6	9'-5"	U
$v_{10}(E)$	32	#8	4'-2"	—
v_{11}	36	#9	19'-1"	—
$v_{12}(E)$	36	#8	9'-0"	—
$v_{13}(E)$	36	#8	12'-0"	—
Concrete Structures, Special		CU YD	20.6	
Drilled Shaft in Soil, 36"		FT	69.6	
Reinforcement Bars		POUND	2930	
Reinforcement Bars, Epoxy Coated		POUND	5590	

Reinforcement Bars designated (E) shall be epoxy coated.
** Length is height of spiral.

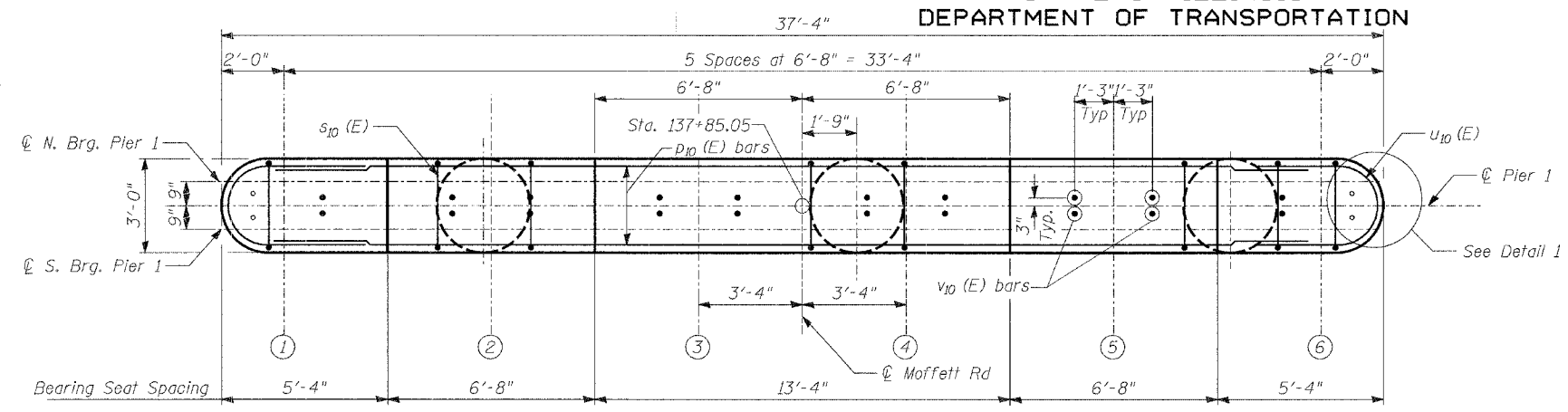

TOP PLAN

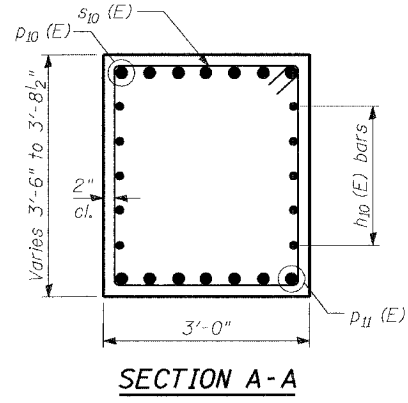

SECTION A-A

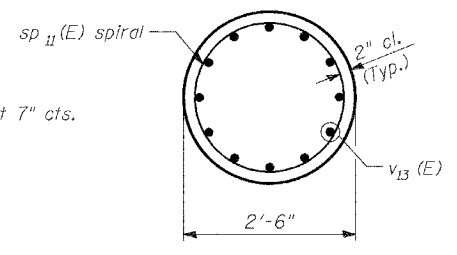

SECTION B-B

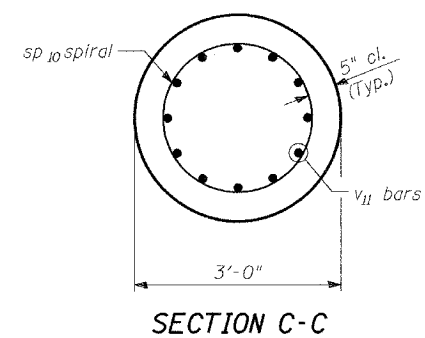

SECTION C-C

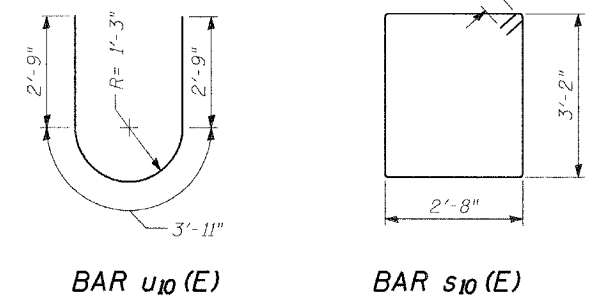

BAR u10(E)

BAR s10(E)

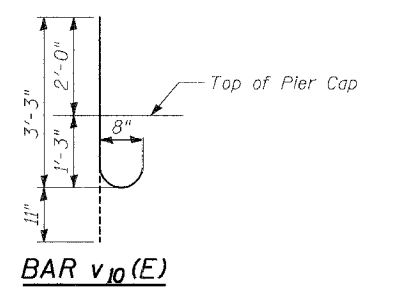

BAR v10(E)

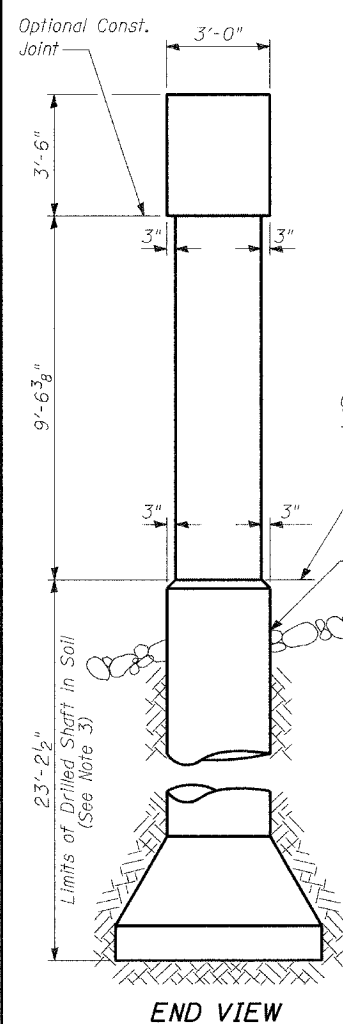

END VIEW

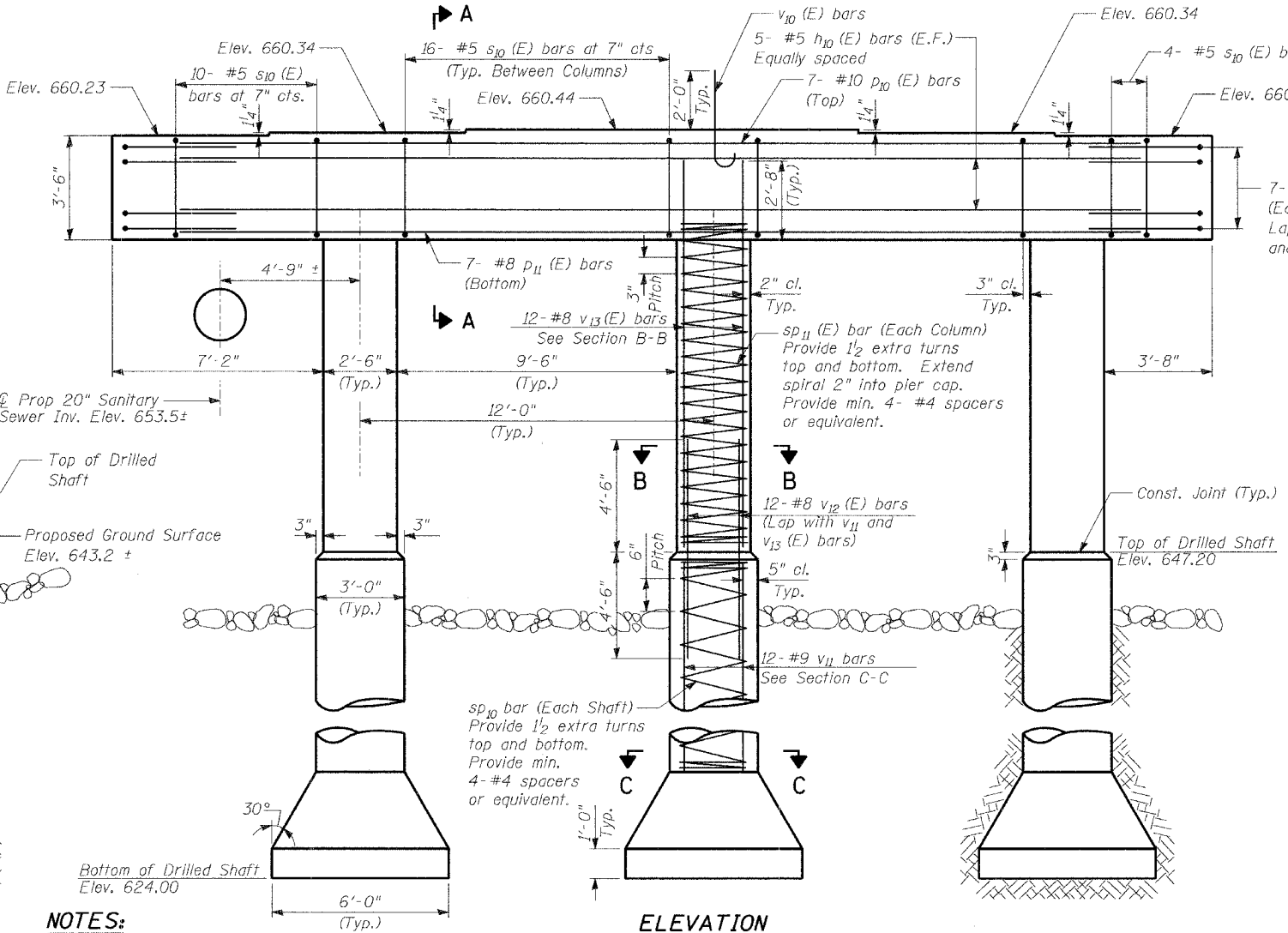

ELEVATION
(Looking North)

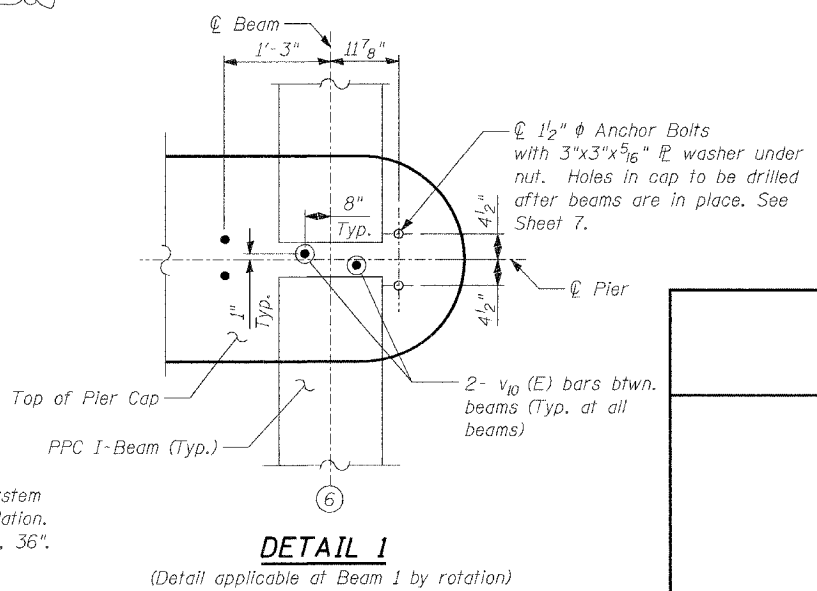

DETAIL 1

(Detail applicable at Beam 1 by rotation)

NOTES:

- Cast steps monolithically with cap.
- Space cap reinforcement to miss anchor bolts.
- The quantities and reinforcement detailing are based on the top of shaft and the estimated elevations shown and may change based on the actual elevations encountered at each shaft and the final top of shaft elevation.
- Provide temporary casing to Elevation 631.00, included in the cost for Drilled Shaft in Soil.
- Minimum lap for spirals = 1'-8"
- Contractor shall be responsible for the design, installation, and subsequent removal of any temporary embankment or support system as required to provide equipment access for drilled shaft installation. Cost shall be included in the unit price for Drilled Shaft in Soil.

TYLIN INTERNATIONAL

DESIGNED	- SP
CHECKED	- AD
DRAWN	- DE
CHECKED	- PF

DATE: 02-23-2005

PIER 1

MOFFETT ROAD OVER
DRAINAGE RAVINE
FAU 2758
LAKE COUNTY
S.N. 049-6803

STATE OF ILLINOIS
DEPARTMENT OF TRANSPORTATION

ROUTE NO.	SECTION	COUNTY	TOTAL SHEETS	SHEET NO.	SHEET NO. - 20
2758	*	LAKE	40	30	30 - SHEETS
FED. ROAD DIST. NO.	ILLINOIS	FED. AID PROJECT-			CONTRACT 83790

02-00025-00-BR

BILL OF MATERIAL

Bar	No.	Size	Length	Shape
$h_{10}(E)$	10	#5	34'-4"	
$p_{10}(E)$	7	#10	34'-4"	
$p_{11}(E)$	7	#8	34'-4"	
$s_{10}(E)$	46	#5	8'-4"	
** sp_{20}	3	#4	19'-5"	WWWWW
** $sp_{21}(E)$	3	#4	9'-11"	WWWWW
$u_{10}(E)$	14	#6	9'-5"	U
$v_{10}(E)$	32	#8	4'-2"	U
v_{11}	36	#9	19'-1"	
$v_{12}(E)$	36	#8	9'-0"	
$v_{13}(E)$	36	#8	12'-0"	
Concrete Structures, Special		CU YD	20.8	
Drilled Shaft in Soil, 36"		FT	69	
Reinforcement Bars		POUND	2915	
Reinforcement Bars, Epoxy Coated		POUND	5600	

Reinforcement Bars designated (E) shall be epoxy coated.
** Length is height of spiral.

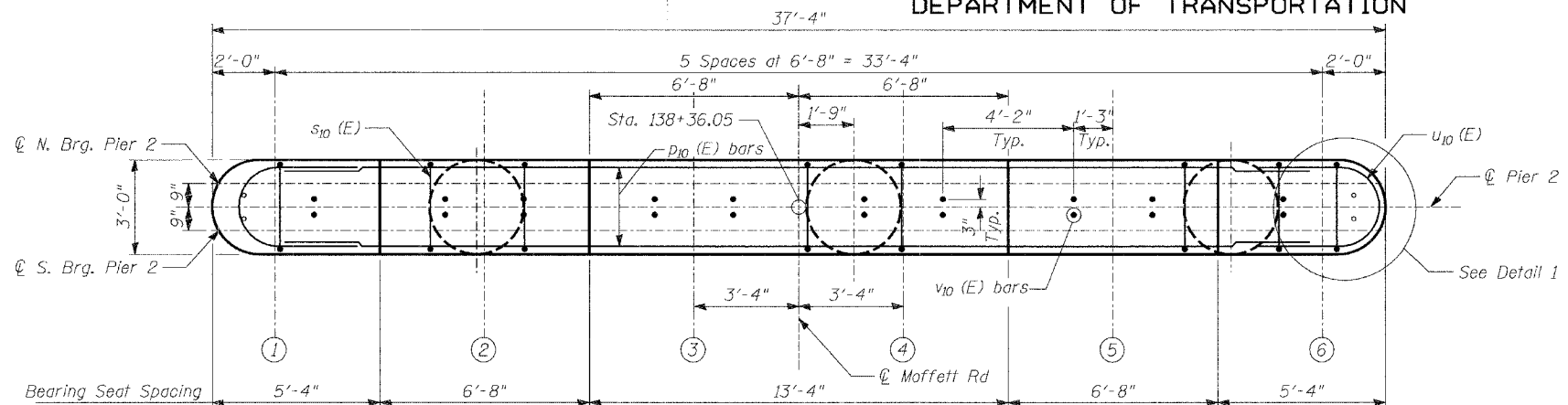

TOP PLAN

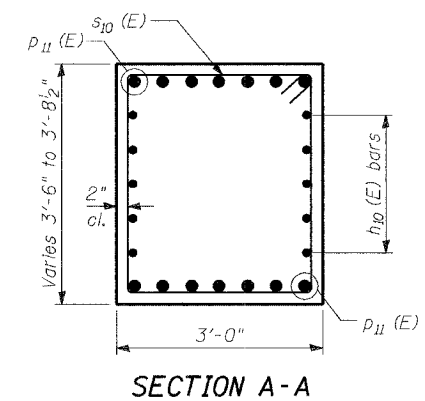

SECTION A-A

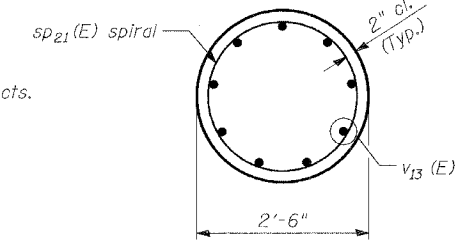

SECTION B-B

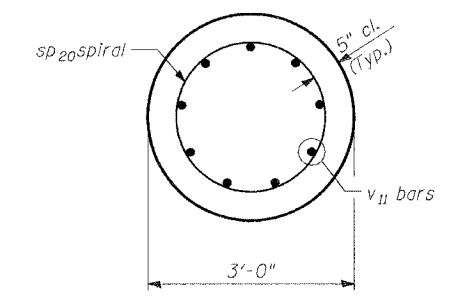

SECTION C-C

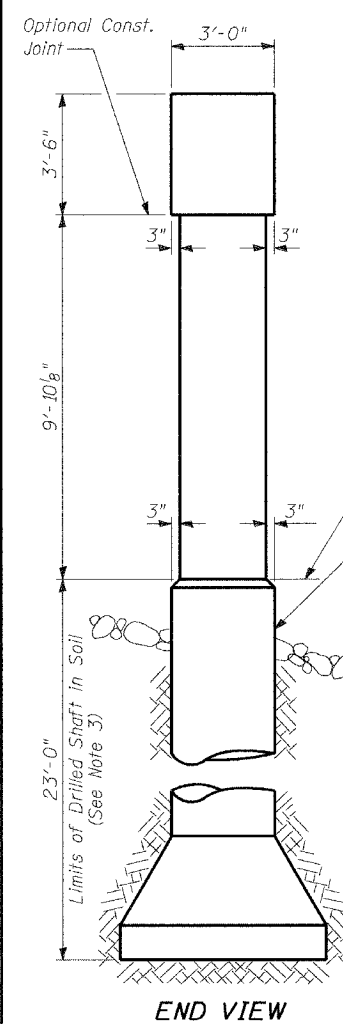

END VIEW

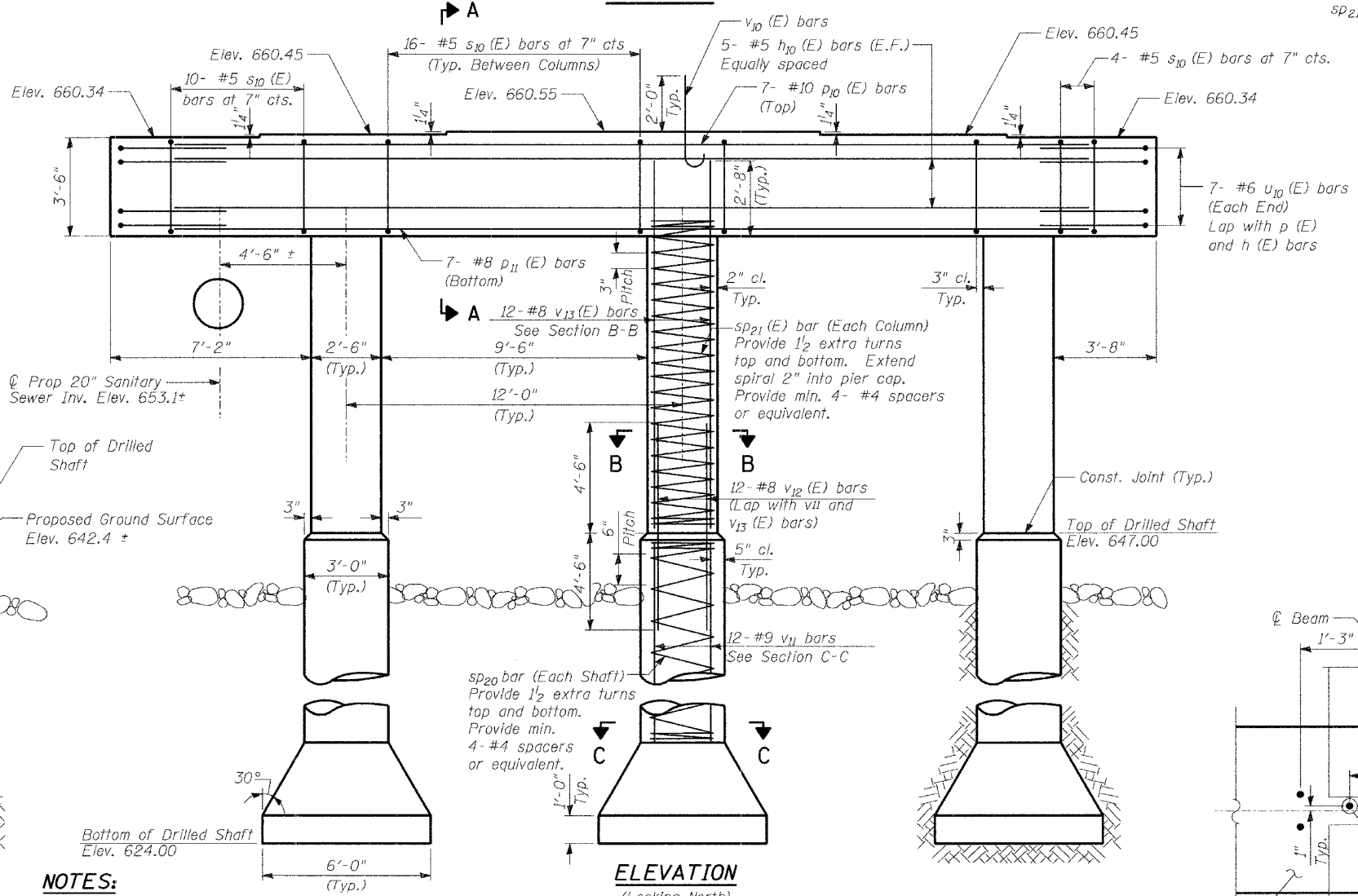

ELEVATION (Looking North)

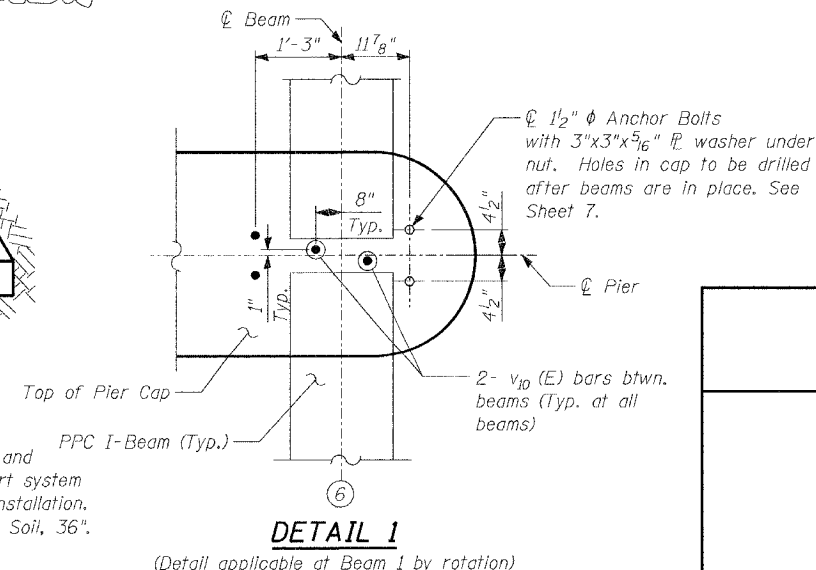

DETAIL 1

(Detail applicable at Beam 1 by rotation)

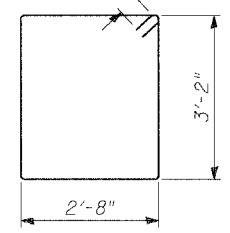

BAR $s_{10}(E)$

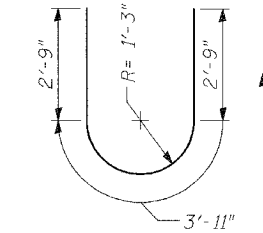

BAR $u_{10}(E)$

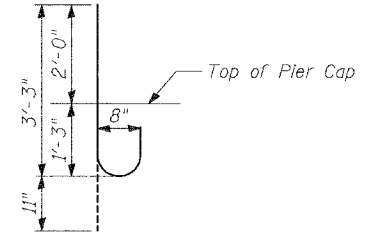

BAR $v_{10}(E)$

NOTES:

1. Cast steps monolithically with cap.
2. Space cap reinforcement to miss anchor bolts.
3. The quantities and reinforcement detailing are based on the top of shaft and the estimated elevations shown and may change based on the actual elevations encountered at each shaft and the final top of shaft elevation.
4. Provide temporary casing to Elev. 631.00
5. Minimum lap for spirals = 1'-8"
6. Contractor shall be responsible for the design, installation, and subsequent removal of any temporary embankment or support system as required to provide equipment access for drilled shaft installation. Cost shall be included in the unit price for Drilled Shaft in Soil, 36".

TYLIN INTERNATIONAL

DESIGNED	- SP
CHECKED	- AD
DRAWN	- DE
CHECKED	- PF

DATE: 02-23-2005

PIER 2

MOFFETT ROAD OVER
DRAINAGE RAVINE
FAU 2758
LAKE COUNTY
S.N. 049-6803

STATE OF ILLINOIS
DEPARTMENT OF TRANSPORTATION

ROUTE NO.	SECTION	COUNTY	TOTAL SHEETS	SHEET NO.
2758	*	LAKE	40	31
FED. ROAD DIST. NO.	ILLINOIS	FED. AID PROJECT-		
* 02-00025-00-BR				

SHEET NO. -21
30 SHEETS
CONTRACT 83790

The Illinois Coil-Lock Anchor Bolt is a proprietary item which is the property of the Illinois Department of Transportation. Use, reproduction or disclosure without express written permission is prohibited and protected under Federal copyright laws. The production and the fabrication of this bolt for use on highway projects in the State of Illinois shall be permitted and there shall be no incurred charges or fees to the manufacturer or the fabricator for producing or fabricating this bolt.

D	E	H	K	"d"
1"	1 1/8"	1 3/16"	1 3/4"	1/4"
1 1/4"	1 3/8"	1 1/16"	2"	3/8"
1 1/2"	1 5/8"	1 5/16"	2 1/8"	1/2"
2"	2 1/8"	1 13/16"	2 7/8"	1/2"
2 1/2"	2 5/8"	2 5/16"	3 3/8"	1"

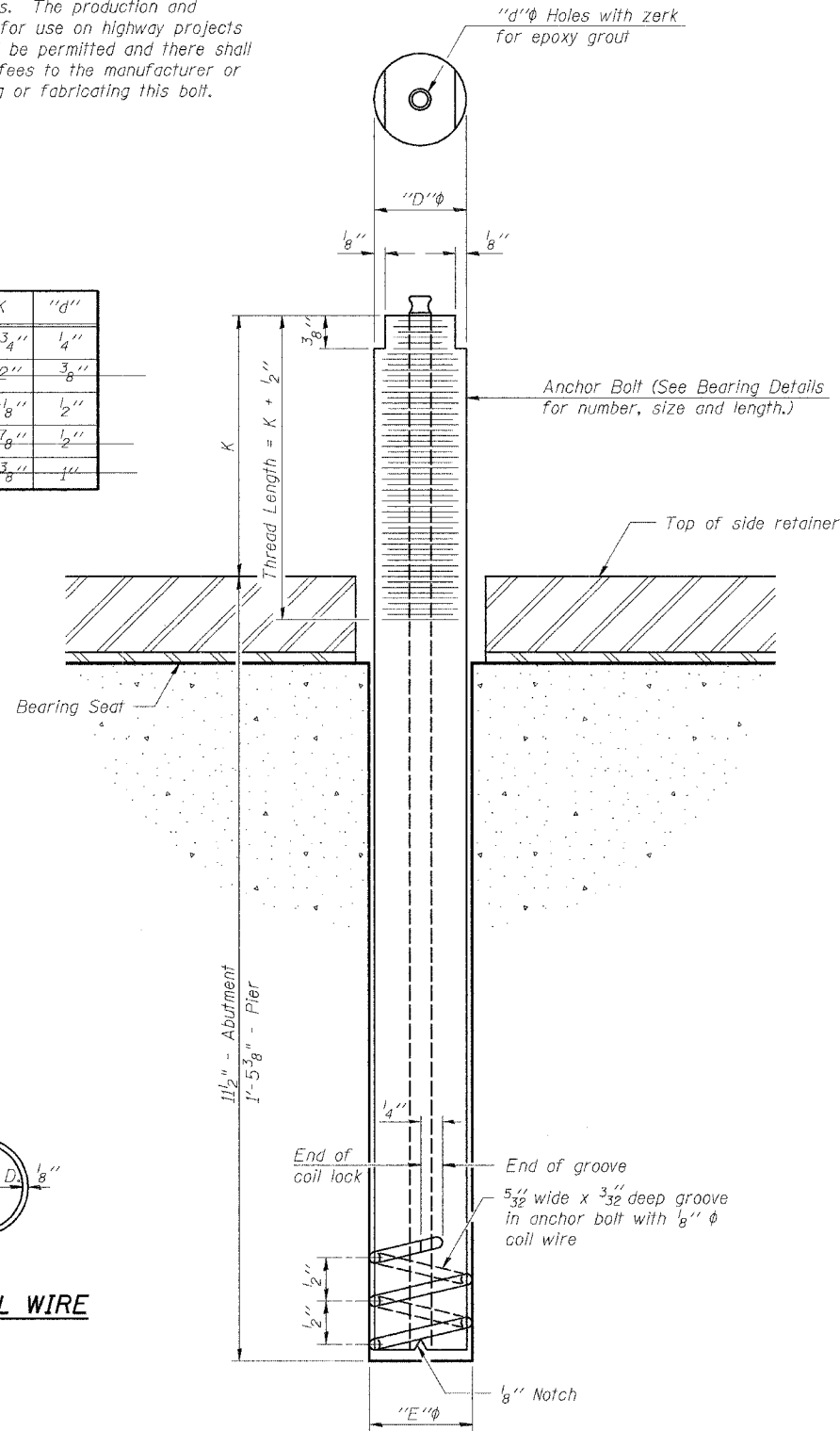

ILLINOIS COIL-LOCK ANCHOR BOLT

PLAN-COIL WIRE

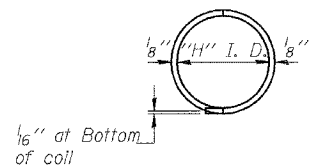

MATERIALS FOR ILLINOIS COIL-LOCK ANCHOR BOLT

The anchor bolt shall be fabricated from cold drawn or hot finished seamless carbon steel mechanical tubing conforming to ASTM A 519, Grade 1026, CW and supplied with hexagonal nuts and cut washers.
The coil wire shall be made of any suitable soft steel wire.
The finished anchor bolt shall be cleaned of rust and other foreign materials and wrapped or packaged to prevent contamination until they are installed.
The epoxy grout shall be a two-component, epoxy resin bonding system conforming to ASTM C 881, Type I, Grade 1 and of a Class suitable for the temperature at installation.

INSTALLATION PROCEDURE for the ILLINOIS COIL-LOCK ANCHOR BOLT

1. With the coil wire in place, the bolt shall be inserted into the hole and turned clockwise to a snug fit in the hole. Nut and washer shall be placed on the bolt. The nut shall be tensioned until the steel base plates are held securely to the concrete bearing seat.
2. Epoxy grout shall be pumped through the zerk fitting with a pressure gun. Pumping shall continue until the epoxy overflows the hole around the bolt shank. After pumping is discontinued, excess epoxy shall be immediately wiped off.

ALTERNATE ANCHOR BOLTS

The Contractor may use, at his option, the capsule or the adhesive cartridge type anchor rods that have been previously tested and given a prior approval by the Department. The Contractor shall install these anchor rods in pre-drilled holes according to the manufacturer's recommendations and procedures.
The capsule or the adhesive cartridge type anchor rods shall be a two part system composed of:
1. A threaded rod stud with nut and washer of the type specified.
2. A sealed glass capsule or a sealed glass adhesive cartridge containing premeasured amounts of the adhesive chemical.

Location	Type
Abut	A307
Pier	A307

ASTM F 1554 Grade 105, ASTM A 449 and AASHTO M 314 Grade 105 anchor bolts may be substituted for the anchor bolts shown above.

ANCHOR BOLT DETAILS

MOFFETT ROAD OVER
DRAINAGE RAVINE
FAU 2758
LAKE COUNTY
S.N. 049-6803

TYLIN INTERNATIONAL

DESIGNED	- SP
CHECKED	- SP
DRAWN	- SP
CHECKED	- PF

DATE: 01-28-2005

STATE OF ILLINOIS
DEPARTMENT OF TRANSPORTATION

ROUTE NO.	SECTION	COUNTY	TOTAL SHEETS	SHEET NO.	SHEET NO. - 22 30 - SHEETS CONTRACT 83790
2758	•	LAKE	40	32	
FED. ROAD DIST. NO.	ILLINOIS	FED. AID PROJECT	• 02-00025-00-BR		

NOTES

Bar splicer assemblies shall be of an approved type and shall develop in tension at least 125 percent of the yield strength of the lapped reinforcement bars.
Splicer rods shall be of minimum 60 ksi yield strength, threaded or coiled full length.
All reinforcement bars shall be lapped and tied to the splicer rods or dowel bars.
Bar splicer assemblies shall be epoxy coated according to the requirements for reinforcement bars.
Other systems of similar design may be submitted to the Engineer for approval. Approval shall be based on certified test results from an approved testing laboratory that the proposed bar splicer assembly satisfies the following requirements:

- ① Minimum Capacity = $1.25 \times f_y \times A_t$
(Tension in kips)
- ② Minimum *Pull-out Strength = $1.25 \times f_{s_{allow}} \times A_t$
(Tension in kips)

Where f_y = Yield strength of lapped reinforcement bars in ksi.
 $f_{s_{allow}}$ = Allowable tensile stress in lapped reinforcement bars in ksi (Service Load)
 A_t = Tensile stress area of lapped reinforcement bars.
* = 28 day concrete

Bar Size to be Spliced	Splicer Rod or Dowel Bar Length	Strength Requirements	
		Min. Capacity kips - tension	Min. Pull-Out Strength kips - tension
#4	1'-8"	14.7	5.9
#5	2'-0"	23.0	9.2
#6	2'-7"	33.1	13.3
#7	3'-5"	45.1	18.0
#8	4'-6"	58.9	23.6
#9	5'-9"	75.0	30.0
#10	7'-3"	95.0	38.0
#11	9'-0"	117.4	46.8

Bar splicer assemblies shall be according to Section 508 of the Standard Specifications, except as noted. The furnishing and installation of bar splicer assemblies will be measured and paid for at the contract unit price each for "BAR SPLICERS."

The diameter of this part is equal or larger than the diameter of bar spliced.
The diameter of this part is the same as the diameter of the bar spliced.

ROLLED THREAD DOWEL BAR



**** ONE PIECE**

Wire Connector

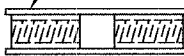

WELDED SECTIONS

BAR SPLICER ASSEMBLY ALTERNATIVES

** Heavy Hex Nuts conforming to ASTM A 563, Grade C, D or DH may be used.

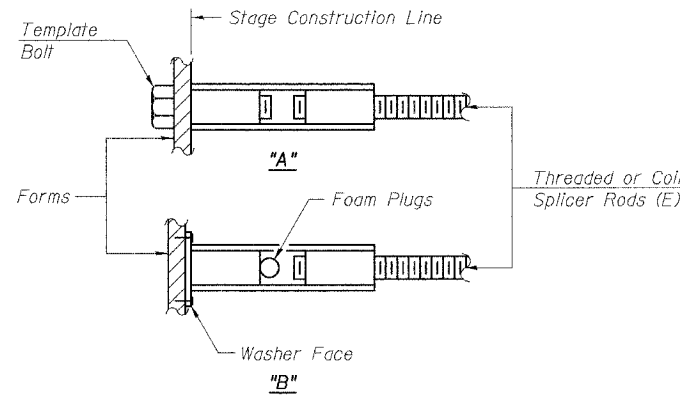

INSTALLATION AND SETTING METHODS

"A" : Set bar splicer assembly by means of a template bolt.
"B" : Set bar splicer assembly by nailing to wood forms or cementing to steel forms.
(E) : Indicates epoxy coating.

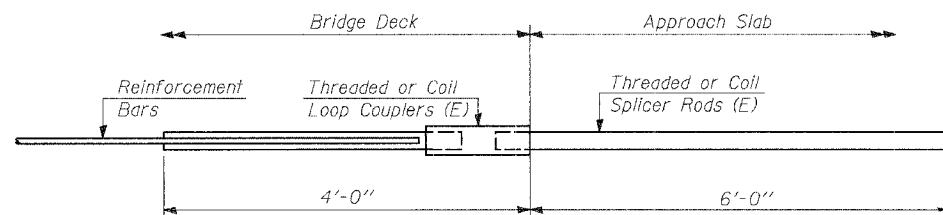

FOR INTEGRAL OR SEMI-INTEGRAL ABUTMENTS

Bar Splicer for #5 bar
Min. Capacity = 23.0 kips - tension
Min. Pull-out Strength = 9.2 kips - tension
No. Required = 80

TYLIN INTERNATIONAL

DESIGNED	- SP
CHECKED	- PF
DRAWN	- SP
CHECKED	- PF

DATE: 02-23-2005

BAR SPLICER DETAILS

MOFFETT ROAD OVER
DRAINAGE RAVINE
FAU 2758
LAKE COUNTY
S.N. 049-6803

STATE OF ILLINOIS
DEPARTMENT OF TRANSPORTATION

ROUTE NO.	SECTION	COUNTY	TOTAL SHEETS	SHEET NO.	SHEET NO. - 23 30 - SHEETS CONTRACT 83790
2758	*	LAKE	40	33	
FED. ROAD DIST. NO. ILLINOIS FED. AID PROJECT - 02-00025-00-BR					

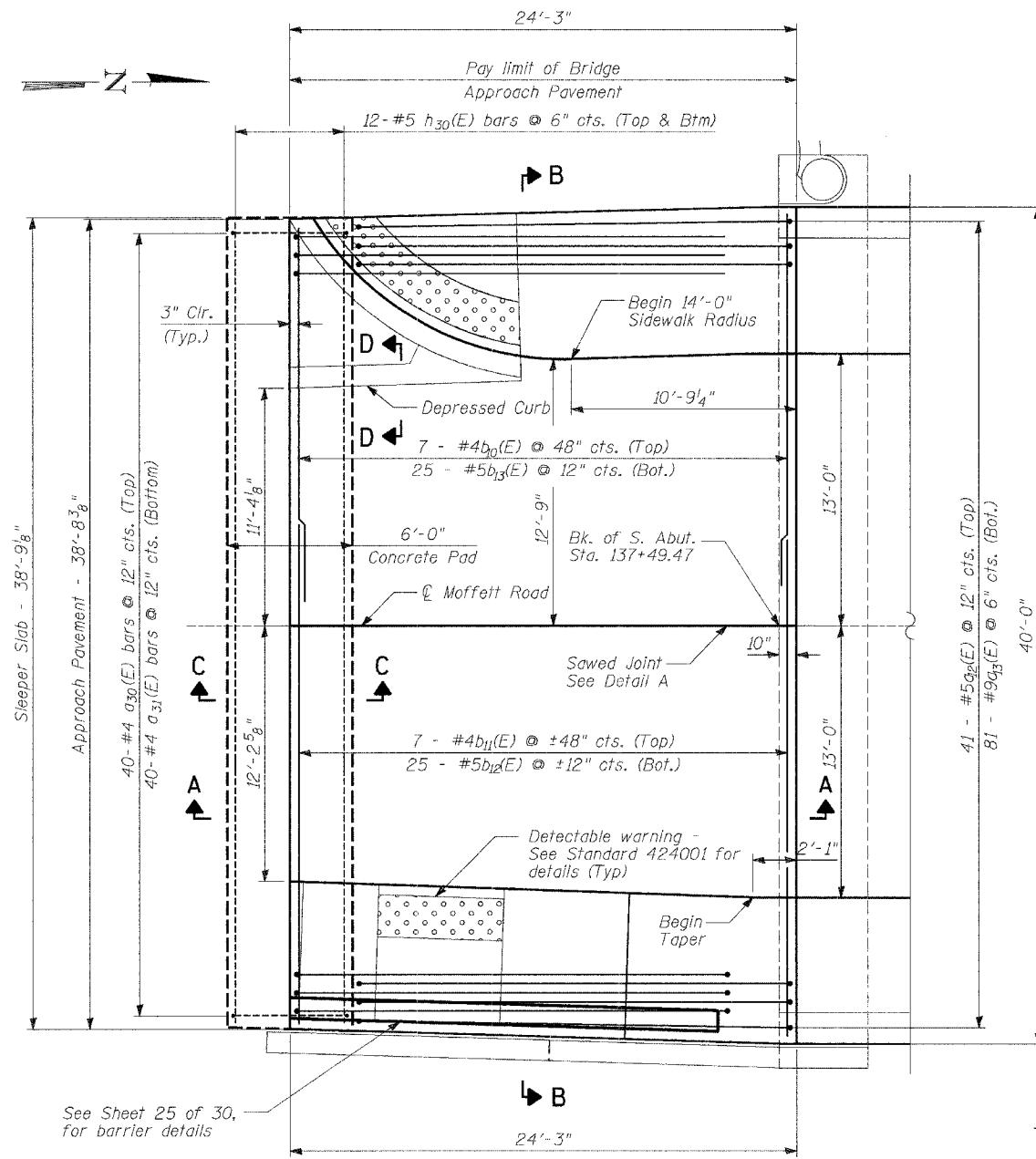

PLAN

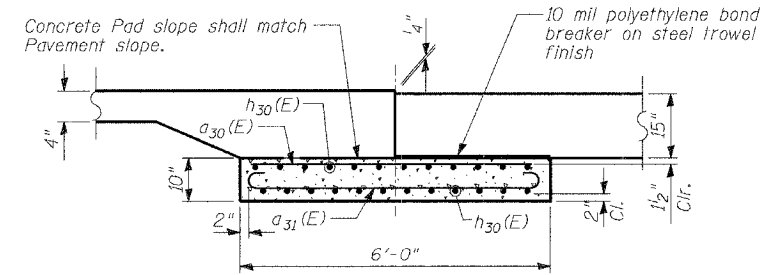

SECTION C-C

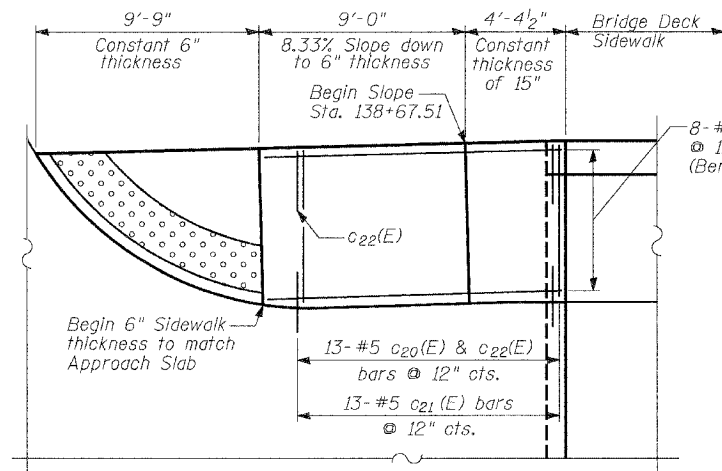

SOUTHWEST SIDEWALK

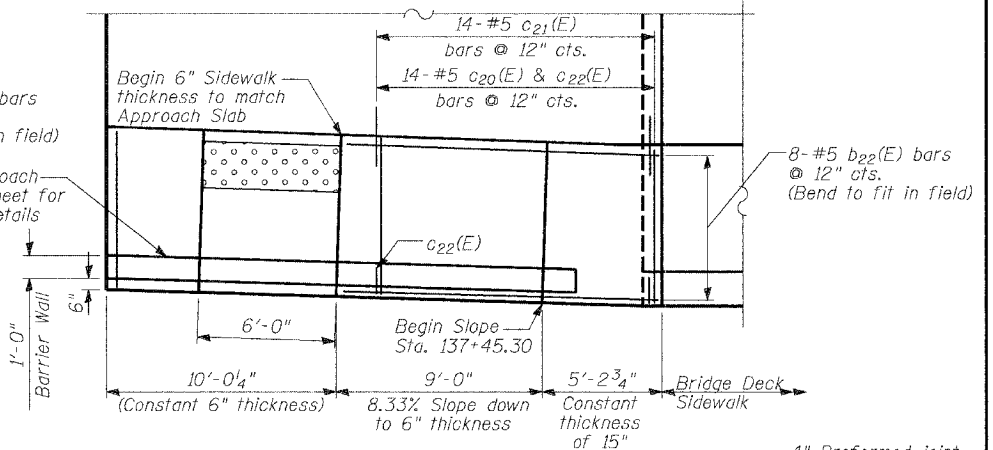

SOUTHEAST SIDEWALK

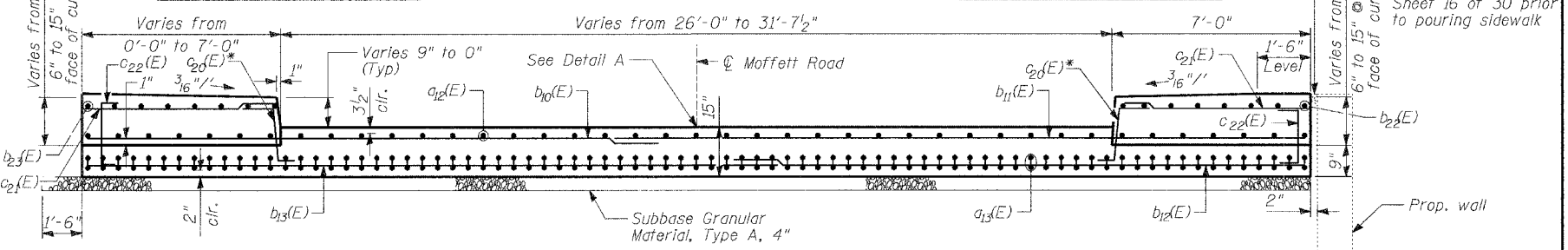

SECTION B-B

*lower bar as needed to fit and maintain bar clearances.

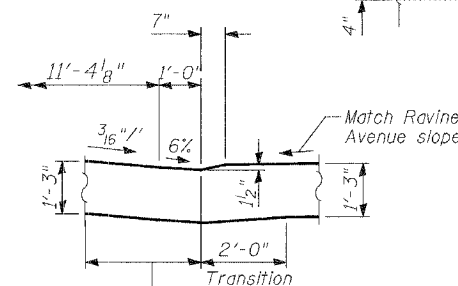

SECTION D-D

Fill with poured joint sealer

DETAIL A

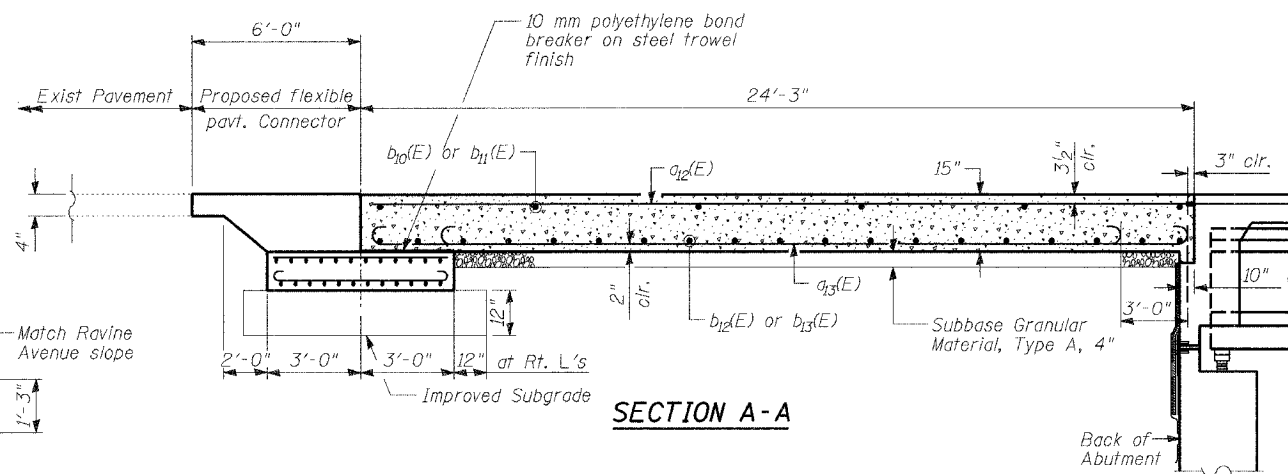

SECTION A-A

NOTES

The construction of the detectable warning detail in the sidewalk will be included in the unit price for Bridge Approach Pavement (Special).
Minimum lap for #4 bars is 1'-8" and #5 bars 2'-2".

TYLIN INTERNATIONAL

DESIGNED	- CM,DE
CHECKED	- SP
DRAWN	- CM,DE
CHECKED	- PF

DATE: 02-23-2005

SOUTH APPROACH PAVEMENT

MOFFETT ROAD OVER
DRAINAGE RAVINE
FAU 2758
LAKE COUNTY
S.N. 049-6803

STATE OF ILLINOIS
DEPARTMENT OF TRANSPORTATION

ROUTE NO.	SECTION	COUNTY	TOTAL SHEETS	SHEET NO.	SHEET NO. - 24 30 - SHEETS CONTRACT 83790
2758	*	LAKE	40	34	
FED. ROAD DIST. NO.	ILL. DIST.	FED. AID PROJECT	* 02-00025-00-BR		

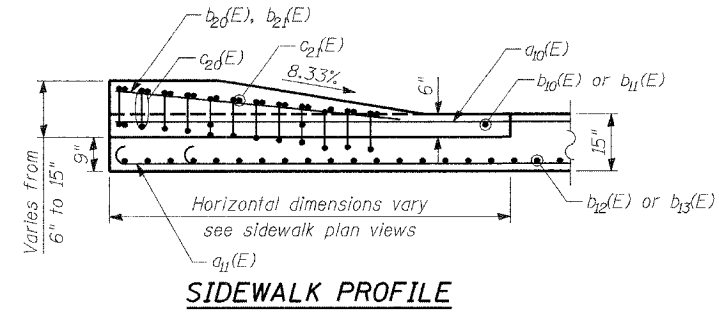
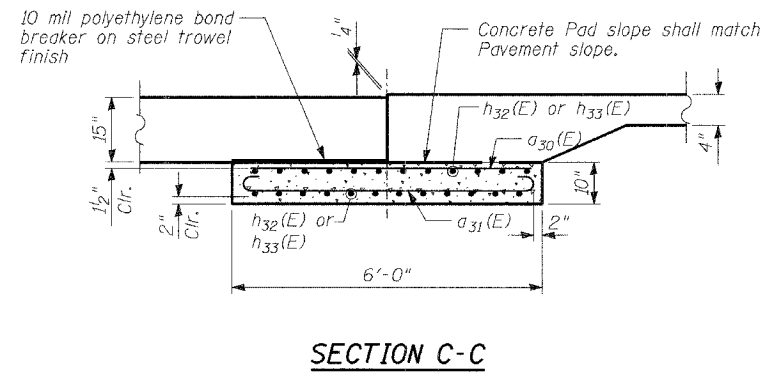
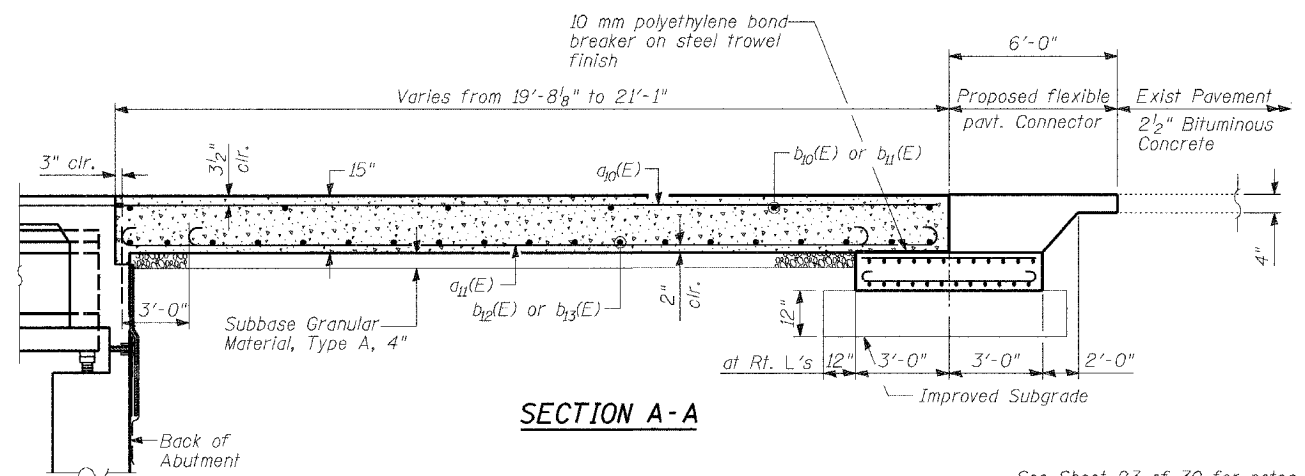
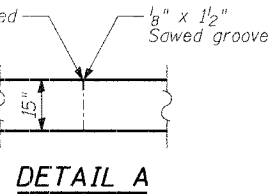
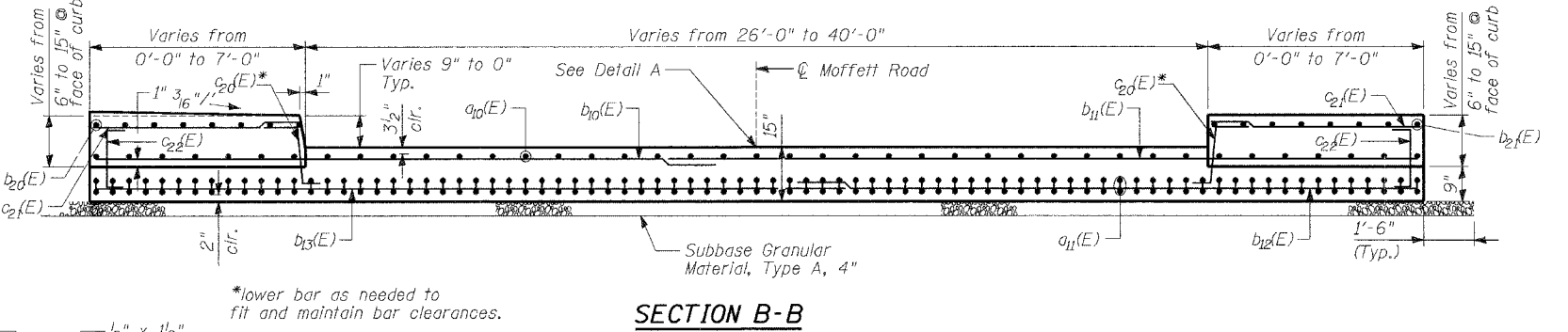
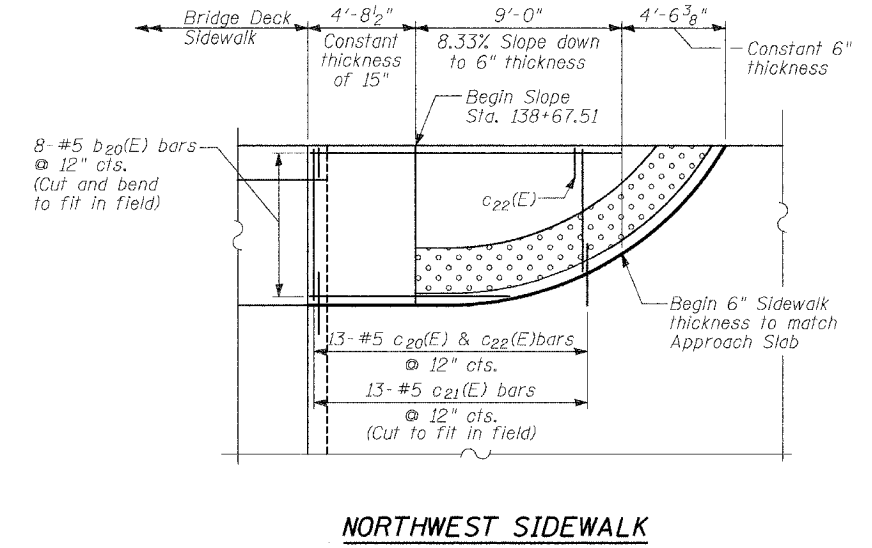
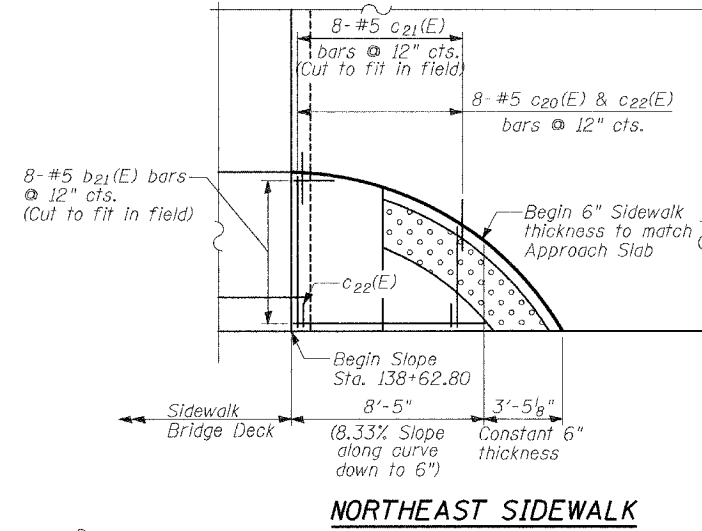
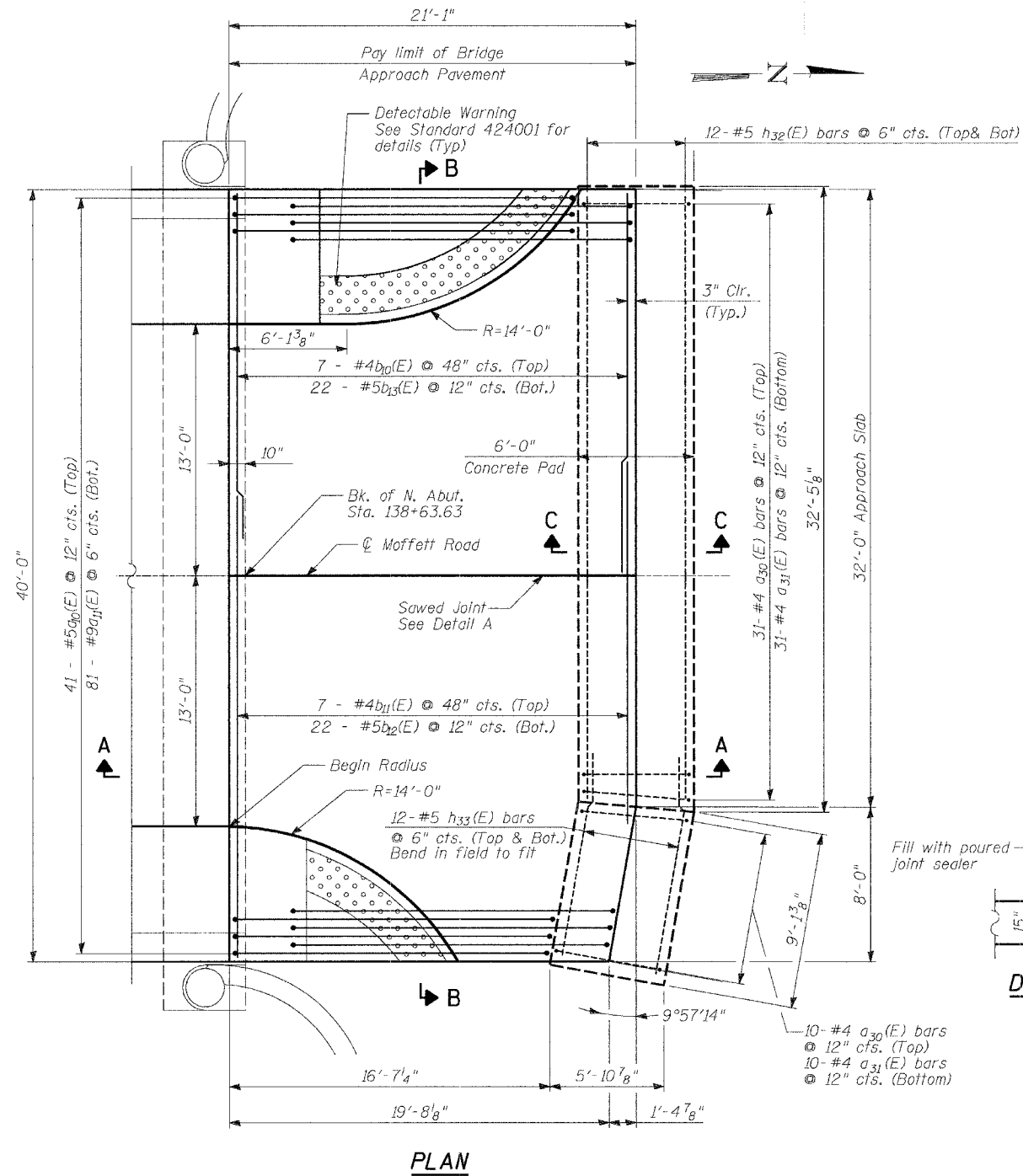

See Sheet 23 of 30 for notes.

NORTH APPROACH PAVEMENT

MOFFETT ROAD OVER DRAINAGE RAVINE
FAU 2758
LAKE COUNTY
S.N. 049-6803

TYLIN INTERNATIONAL

DESIGNED	- CM,DE
CHECKED	- SP
DRAWN	- CM,DE
CHECKED	- PF

DATE: 02-23-2005

STATE OF ILLINOIS
DEPARTMENT OF TRANSPORTATION

ROUTE NO.	SECTION	COUNTY	TOTAL SHEETS	SHEET NO.	SHEET NO. -25 30 - SHEETS CONTRACT 83790
2758	*	LAKE	40	35	
FED. ROAD DIST. NO.	ILLINOIS	FED. AID PROJECT	• 02-00025-00-BR		

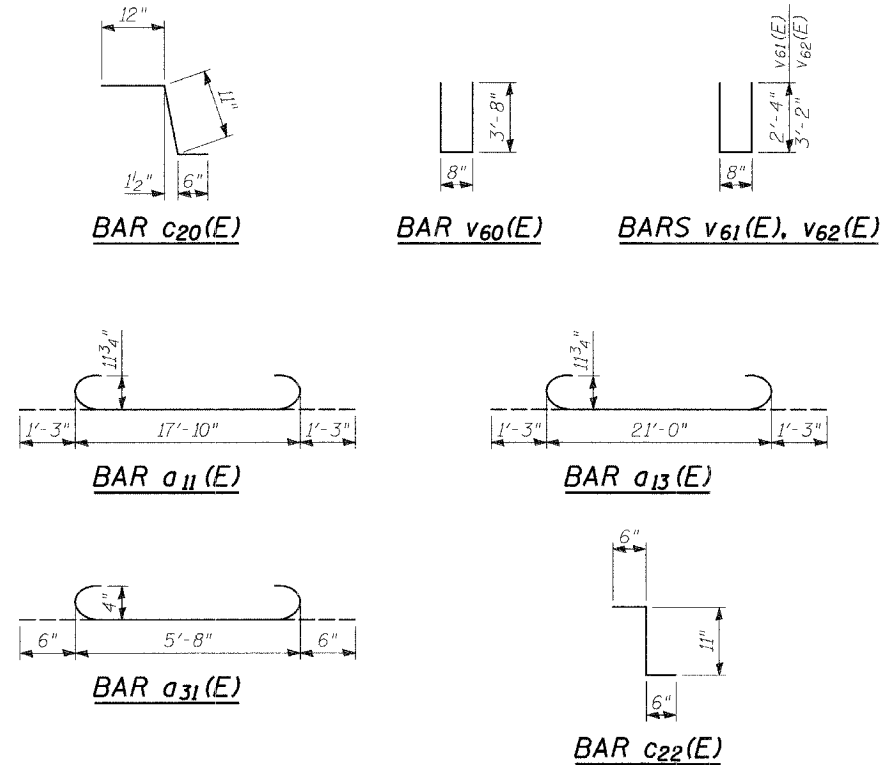

**NORTH APPROACH
BILL OF MATERIAL**

Bar	No.	Size	Length	Shape
a ₁₀ (E)	41	#5	20'-9"	—
a ₁₁ (E)	81	#9	20'-4"	⤵
a ₃₀ (E)	41	#4	5'-8"	—
a ₃₁ (E)	41	#4	6'-8"	⤵
b ₁₀ (E)	7	#4	17'-7"	—
b ₁₁ (E)	7	#4	23'-7"	—
b ₁₂ (E)	22	#5	17'-7"	—
b ₁₃ (E)	22	#5	23'-7"	—
b ₂₀ (E)	8	#5	13'-4"	—
b ₂₁ (E)	8	#5	8'-3"	—
c ₂₀ (E)	21	#5	2'-5"	⤵
c ₂₁ (E)	21	#5	6'-8"	—
c ₂₂ (E)	21	#5	1'-11"	⤵
h ₃₂ (E)	24	#5	31'-8"	—
h ₃₃ (E)	24	#5	17'-1"	—
Reinforcement Bars, Epoxy Coated		POUND	9610	
Bridge Approach Pavement (Special)		SQ YD	94	

The volume of concrete for the sidewalk area is 5.7 CU YD.

**SOUTH APPROACH
BILL OF MATERIAL**

Bar	No.	Size	Length	Shape
a ₁₂ (E)	41	#5	23'-11"	—
a ₁₃ (E)	81	#9	23'-6"	⤵
a ₃₀ (E)	40	#4	5'-8"	—
a ₃₁ (E)	40	#4	6'-8"	⤵
b ₁₀ (E)	7	#4	17'-7"	—
b ₁₁ (E)	7	#4	23'-7"	—
b ₁₂ (E)	25	#5	17'-7"	—
b ₁₃ (E)	25	#5	23'-7"	—
b ₂₂ (E)	8	#5	13'-9"	—
b ₂₃ (E)	8	#5	13'-0"	—
c ₂₀ (E)	27	#5	2'-5"	⤵
c ₂₁ (E)	27	#5	6'-8"	—
c ₂₂ (E)	27	#5	1'-11"	⤵
h ₃₀ (E)	24	#5	38'-6"	—
h ₃₁ (E)	24	#4	20'-6"	—
v ₆₀ (E)	21	#4	8'-0"	⤵
v ₆₁ (E)	10	#4	5'-4"	⤵
v ₆₂ (E)	11	#4	7'-0"	⤵
Architectural Concrete		CU YD	2.4	
Reinforcement Bars, Epoxy Coated		POUND	11300	
Bridge Approach Pavement (Special)		SQ YD	108	

The volume of concrete for the sidewalk area is 9.3 CU YD.

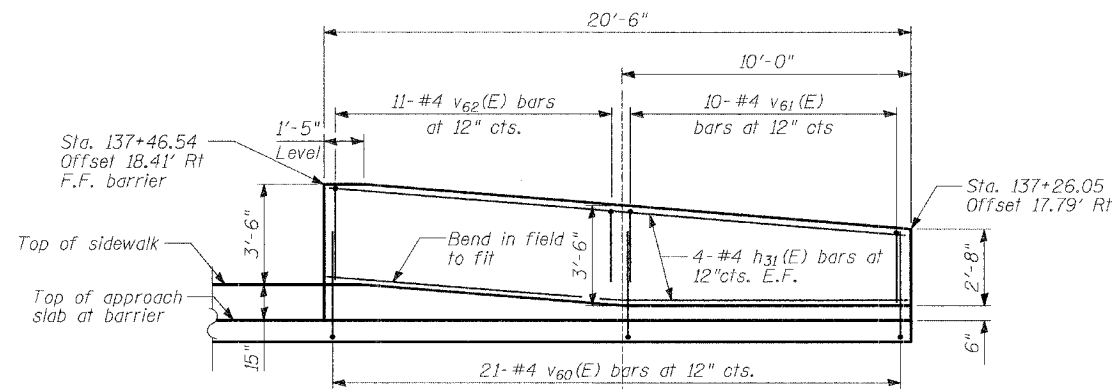

**SOUTHEAST SIDEWALK
BARRIER WALL**
Offsets are to wall F.F.

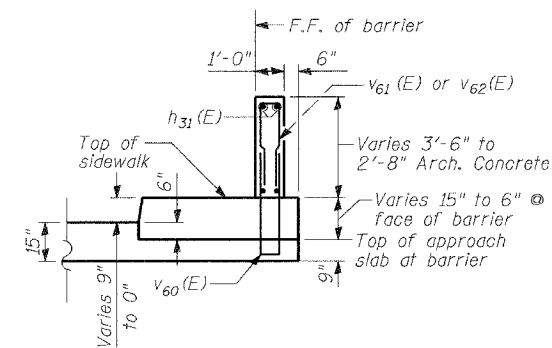

**SECTION THRU SOUTHEAST
SIDEWALK AT BARRIER WALL**

Note:
Minimum lap for #4 bars shall be 1'-8"

NOTES

Reinforcement Bars designated (E) shall be Epoxy Coated.

Reinforcement Bars in the above tables are included in the unit price for Bridge Approach Pavement (Special). See Special Provisions.

APPROACH PAVEMENT DETAILS

MOFFETT ROAD OVER
DRAINAGE RAVINE
FAU 2758
LAKE COUNTY
S.N. 049-6803

TYLIN INTERNATIONAL

DESIGNED	- CM,DE
CHECKED	- SP
DRAWN	- CM,DE
CHECKED	- PF

DATE: 02-23-2005

13/01/05 10:31:05 AM

STATE OF ILLINOIS
DEPARTMENT OF TRANSPORTATION

ROUTE NO.	SECTION	COUNTY	LIST SHEETS	SHEET NO.	SHEET NO. -26
2758	*	LAKE	40	36	30 - SHEETS
FED. ROAD DIST. NO.	ILLINOIS	FED. AID PROJECT	CONTRACT 83790		
* 02-00025-00-BR					

BILL OF MATERIAL

ITEM	UNIT	TOTAL
Form Liner Textured Surface	SQ YD	123
Coating System for Concrete	SQ FT	4000

All exposed surface of the piers and the abutments shall be coated, with the exception of the top of caps.

CONCRETE COATING

LOCATION	TOTAL (SQ FT)
North Abutment	535
North Abutment Retaining Walls	88
South Abutment	325
South Abutment Retaining Walls	147
Piers	1278
Deck Fascia	921
Fascia Beams	706

With the exception of the fascia beams, the color of the concrete coating shall be Cloud 57BR - See Special Provisions

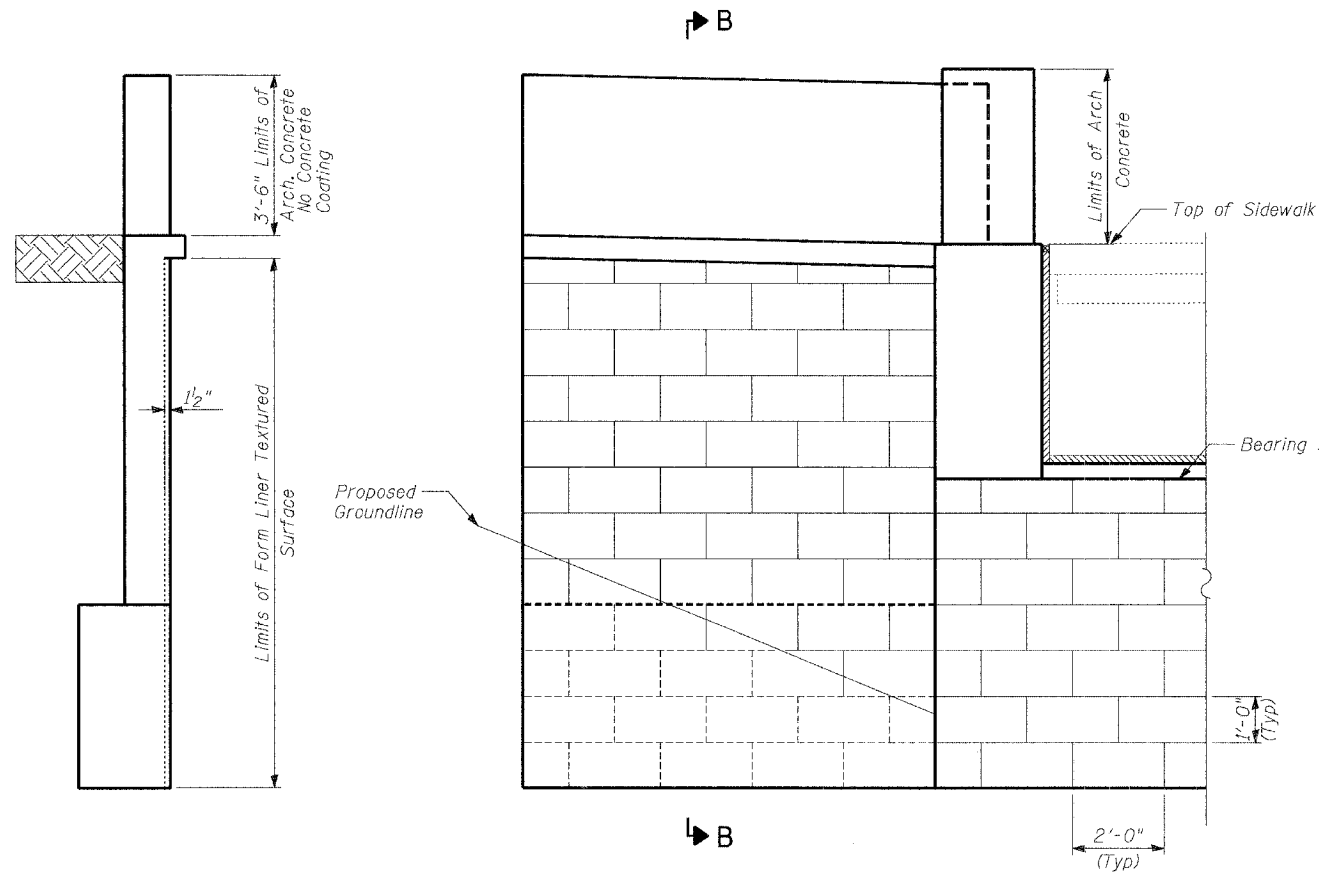

SECTION B-B

TYPICAL WINGWALL ELEVATION

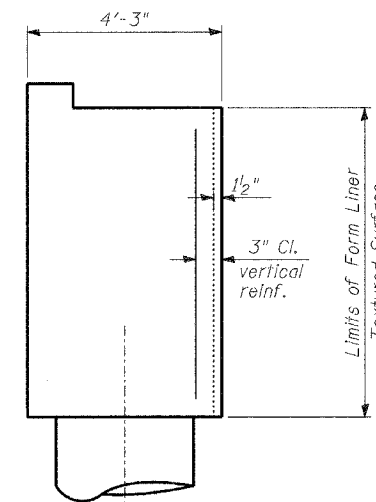

SECTION A-A

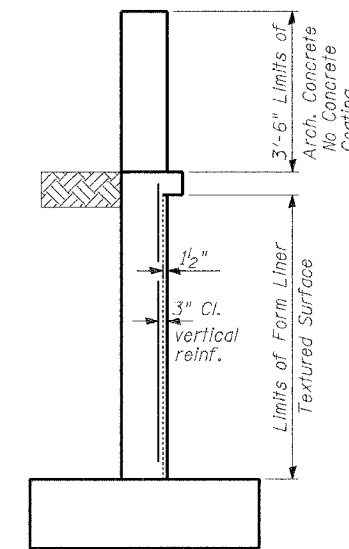

SECTION THRU RETAINING WALLS

Note: 3'-6" wall atop retaining wall not provided at South Abutment, East wall.

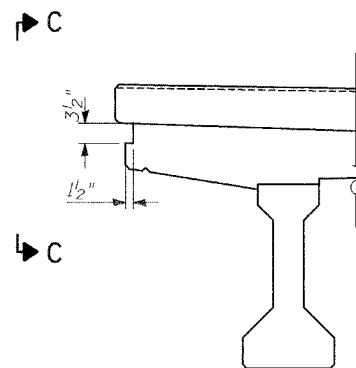

SECTION THRU DECK FASCIA

Note: Cost of Relief treatment to deck fascia as shown shall be included in the unit price of Concrete Superstructure.

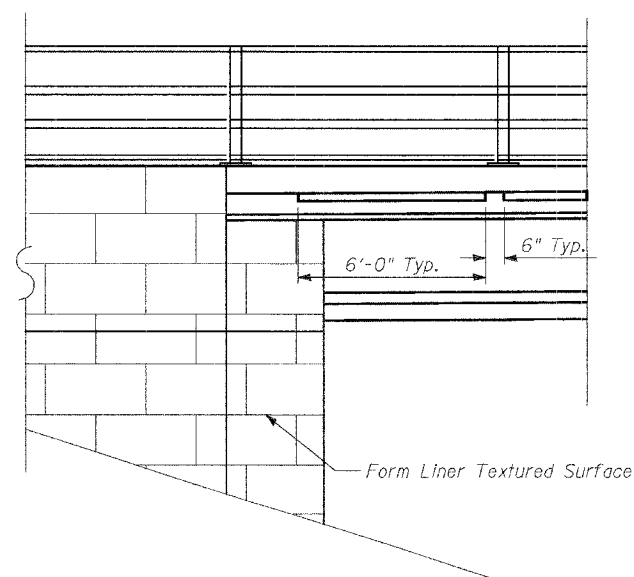

VIEW C-C

(Shown at South Abutment, East Face)

Cloud 57BR - See Special Provisions

RAL 6003 - See Special Provisions

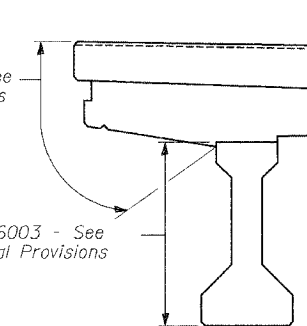

CONCRETE COATING OF FASCIA

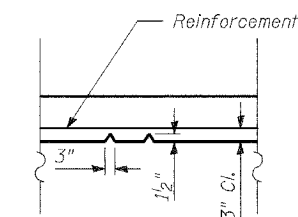

SECTION D-D

Cost of architectural finish, as shown in "ELEVATION OF NORTH & SOUTH ABUTMENT RETAINING WALLS" shall be included in the unit price of Architectural Concrete.

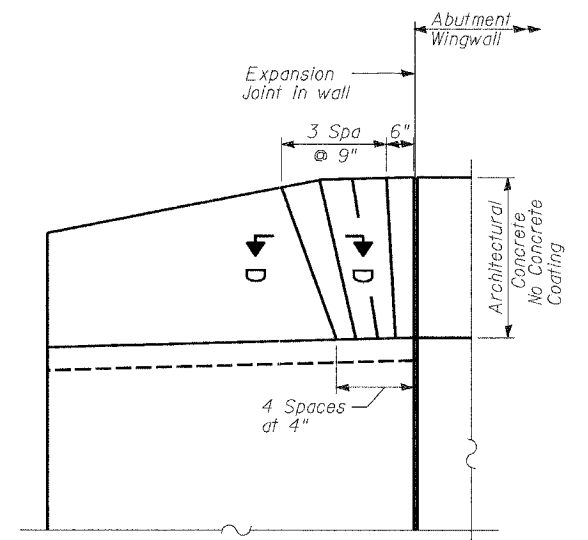

ELEVATION OF NORTH & SOUTH ABUTMENT RETAINING WALLS

(Above detail does not apply at South Abutment, East wall)

ARCHITECTURAL DETAILS

MOFFETT ROAD OVER
DRAINAGE RAVINE
FAU 2758
LAKE COUNTY
S.N. 049-6803

TYLIN INTERNATIONAL

DESIGNED	- SP
CHECKED	- PF
DRAWN	- SP
CHECKED	- PF

DATE: 02-23-2005

STATE OF ILLINOIS
DEPARTMENT OF TRANSPORTATION

ROUTE NO.	SECTION	COUNTY	TOTAL SHEETS	SHEET NO.
2758	*	LAKE	40	38
FED. ROAD DIST. NO.		ILLINOIS	FED. AID PROJECT	
02-00025-00-BR				

SHEET NO. - 28
30 - SHEETS
CONTRACT 83790

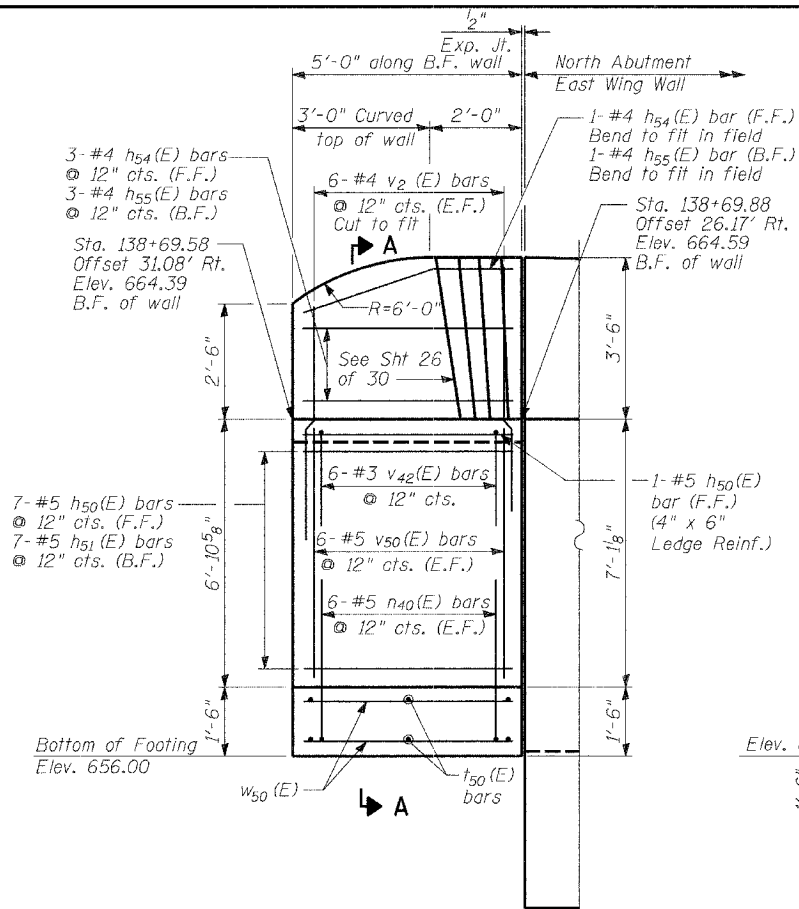

ELEVATION OF NORTHEAST WALL
(Looking South)

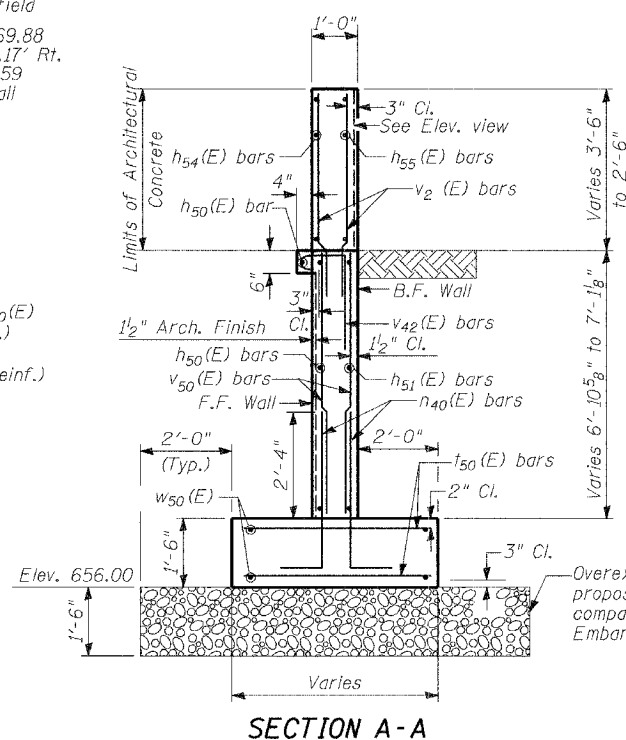

SECTION A-A

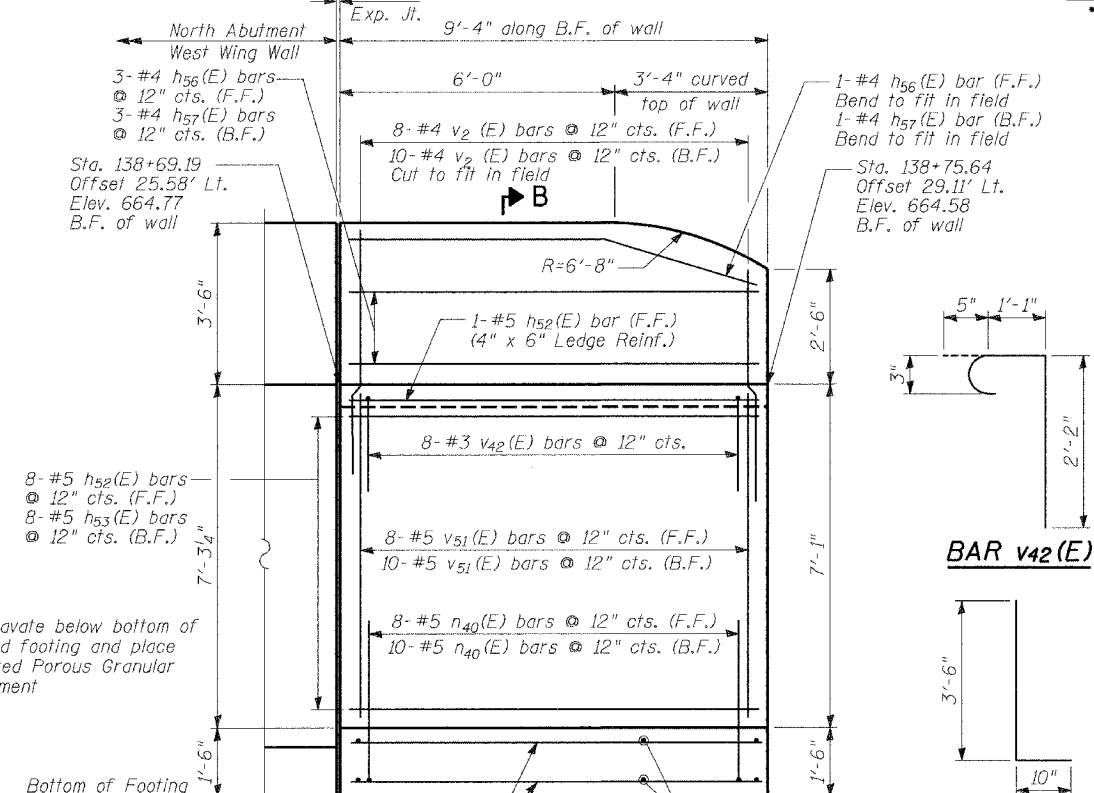

ELEVATION OF NORTHWEST WALL
(Looking Southwest)

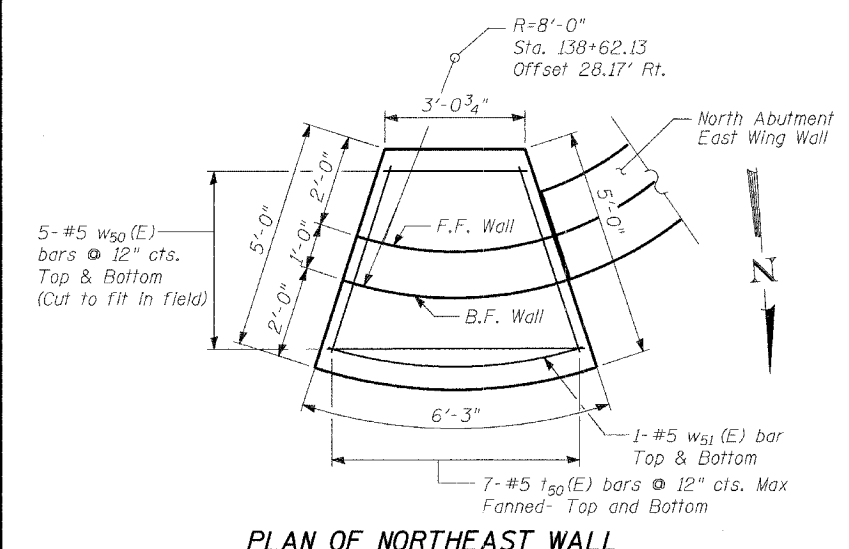

PLAN OF NORTHEAST WALL

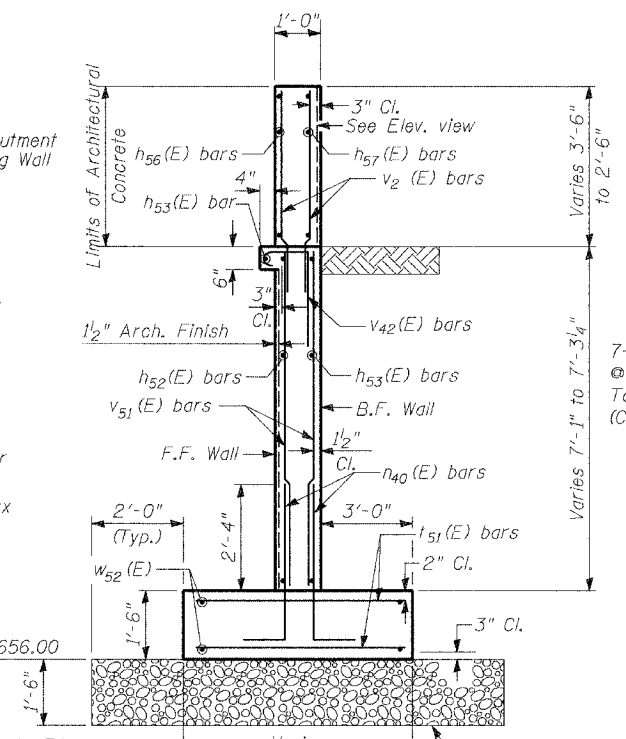

SECTION B-B

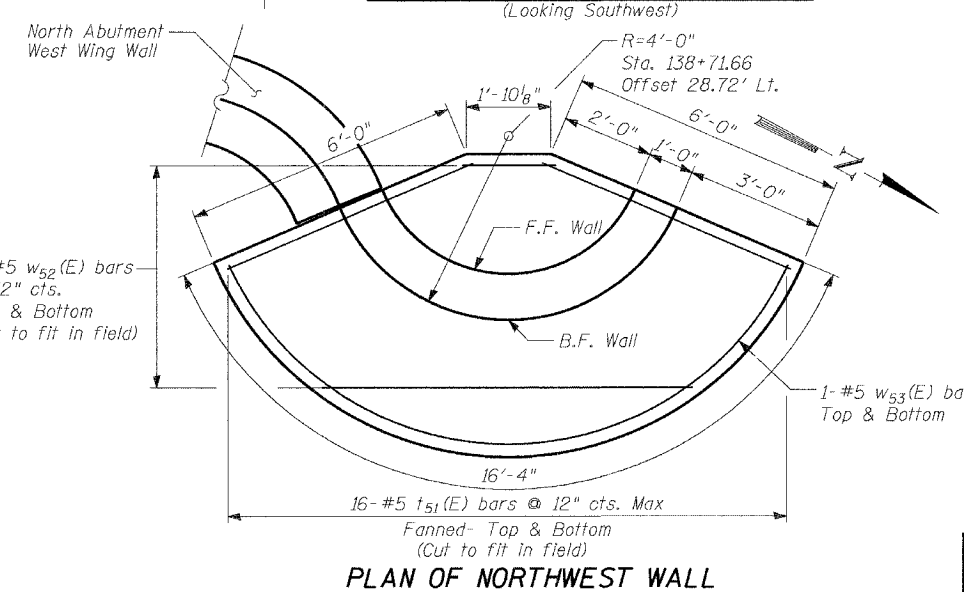

PLAN OF NORTHWEST WALL

BILL OF MATERIAL

Bar	No.	Size	Length	Shape
h50(E)	8	#5	4'-1"	()
h51(E)	7	#5	4'-7"	()
h52(E)	9	#5	7'-0"	()
h53(E)	8	#5	8'-7"	()
h54(E)	4	#4	4'-1"	()
h55(E)	4	#4	4'-7"	()
h56(E)	4	#4	7'-0"	()
h57(E)	4	#4	8'-7"	()
n40(E)	30	#5	4'-4"	()
t50(E)	14	#5	4'-8"	()
t51(E)	32	#5	6'-3"	()
v2(E)	30	#4	4'-4"	()
v42(E)	14	#3	3'-8"	()
v50(E)	12	#5	6'-8"	()
v51(E)	18	#5	6'-11"	()
w50(E)	10	#5	5'-8"	()
w51(E)	2	#5	5'-7"	()
w52(E)	14	#5	11'-8"	()
w53(E)	2	#5	15'-3"	()
Concrete Structures	Cu Yd		7.9	
Architectural Concrete	Cu Yd		1.6	
Reinforcement Bars, Epoxy Coated	Pounds		1280	
Structure Excavation	Cu Yd		75	
Porous Granular Embankment	Cu Yd		31	

Reinforcement bars designated (E) shall be epoxy coated.

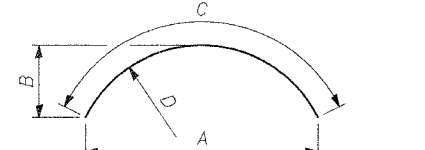

Bar	A	B	C	D
h50(E), h54(E)	4'-3 3/4"	3 1/2"	4'-1"	R=7'-1 1/2"
h51(E), h55(E)	4'-6 1/4"	4"	4'-7"	R=7'-10 1/2"
h52(E), h56(E)	5'-8 1/4"	1'-9 1/4"	7'-0"	R=3'-2"
h53(E), h57(E)	6'-10 7/8"	2'-2"	8'-7"	R=3'-10"
w51(E)	5'-6 3/8"	4 7/8"	5'-7"	R=9'-6"
w53(E)	12'-2 1/2"	3'-10 1/2"	15'-3"	R=6'-9"

NORTH ABUTMENT RETAINING WALLS

MOFFETT ROAD OVER
DRAINAGE RAVINE
FAU 2758
LAKE COUNTY
S.N. 049-6803

TYLIN INTERNATIONAL

DESIGNED	- SP
CHECKED	- AD
DRAWN	- DE
CHECKED	- PF

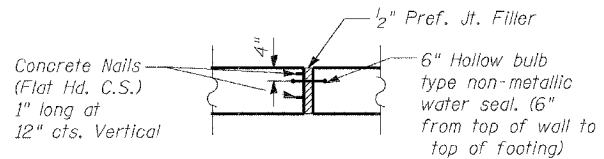

EXPANSION JOINT DETAIL

NOTES

For Architectural finish, see Sheet 26 of 30.

DATE: 02-23-2005

STATE OF ILLINOIS
DEPARTMENT OF TRANSPORTATION

SB-1

SB-1

PAGE 1 of 2
DATE April 27, 2004
LOGGED BY TOB
OBA JOB No. 03356

OBA
O'BRIEN & ASSOCIATES, INC.
CONSULTING ENGINEERS
1229 S. JAMES ST., JOLIET, ILL. 61705
(815) 738-4444 FAX (815) 738-2376

SOIL BORING LOG

ROUTE FAP Rt. 330 DESCRIPTION Moffett Road Bridge Over Un-Named Ravine
SECTION I28 R-2 LOCATION Lake Bluff, Illinois
COUNTY Lake DRILLING METHOD 3.25" Hollow Stem Auger HAMMER TYPE D-120 Safety

STRUCT. NO. 049-6801 Station 137+50.47 to 183+60.80
BORING NO. SB-1 Station: 137+30
Offset: 6' Left
Ground Surface Elev. 663.7

Surface Water Elev. 632.2
Stream Bed Elev. n/a
Groundwater Elevation:
First Encounter 620.7
Upon Completion Dry
After _____ Hrs. _____

DEPTH (ft)	BLOW COUNT (blows/ft)	UCS (tsf)	MOISTURE (%)	DEPTH (ft)	BLOW COUNT (blows/ft)	UCS (tsf)	MOISTURE (%)
0-6				0-5			
6-4				4-8			
4-5	1.25P	15		8-11	2.4B	16	
5-4				11-6			11.3
4-6				6-10			
6-5	1.5P	13		10-12	2.8B	16	
5-10				12-7			
10-12	3.2B	16		7-8			
5-8			11.6	8-12	1.5B	16	
8-10				12-5			11.3
10-8				5-8			
8-10	3.1B	15		8-10			
10-15				10-11	1.9B	16	
15-8				11-15			
8-12	2.1B	15		15-20	5.4B	14	
12-5				20-15			
5-10	1.4B	16		15-5			
10-5			11.1	5-6			
5-7				6-10			
7-8	1.9B	16		10-7			
8-20				7-10			
				10-4	4.3B	17	

PAGE 1 of 2
DATE April 27, 2004
LOGGED BY TOB
OBA JOB No. 03356

OBA
O'BRIEN & ASSOCIATES, INC.
CONSULTING ENGINEERS
1229 S. JAMES ST., JOLIET, ILL. 61705
(815) 738-4444 FAX (815) 738-2376

SOIL BORING LOG

ROUTE FAP Rt. 330 DESCRIPTION Moffett Road Bridge Over Un-Named Ravine
SECTION I28 R-2 LOCATION Lake Bluff, Illinois
COUNTY Lake DRILLING METHOD 3.25" Hollow Stem Auger HAMMER TYPE D-120 Safety

STRUCT. NO. 049-6801 Station 137+50.47 to 183+60.80
BORING NO. SB-1 Station: 137+30
Offset: 6' Left
Ground Surface Elev. 663.7

Surface Water Elev. 632.2
Stream Bed Elev. n/a
Groundwater Elevation:
First Encounter 620.7
Upon Completion Dry
After _____ Hrs. _____

DEPTH (ft)	BLOW COUNT (blows/ft)	UCS (tsf)	MOISTURE (%)	DEPTH (ft)	BLOW COUNT (blows/ft)	UCS (tsf)	MOISTURE (%)
0-6				0-5			
6-4				4-8			
4-5	1.25P	15		8-11	2.4B	16	
5-4				11-6			11.3
4-6				6-10			
6-5	1.5P	13		10-12	2.8B	16	
5-10				12-7			
10-12	3.2B	16		7-8			
5-8			11.6	8-12	1.5B	16	
8-10				12-5			11.3
10-15				5-8			
15-8				8-10	3.1B	15	
8-10	3.1B	15		10-11	1.9B	16	
10-15				11-15			
15-8				15-20	5.4B	14	
8-12	2.1B	15		20-15			
12-5				15-5			
5-10	1.4B	16		5-6			
10-5			11.1	6-10			
5-7				10-7			
7-8	1.9B	16		7-10			
8-20				10-4	4.3B	17	

The Unconfined Compressive Strength (UCS) Failure Mode is indicated by (B-Bulge, S-Shear, P-Penetrometer) ST-Shelby Tube Sample VS-Vane Shear Test
The SPT (N value) is the sum of the last two blow values in each sampling zone (AASHTO T206) The Unit Dry Weight (pcf) is noted in Italics above moist (%)
NR-No Recovery

The Unconfined Compressive Strength (UCS) Failure Mode is indicated by (B-Bulge, S-Shear, P-Penetrometer) ST-Shelby Tube Sample VS-Vane Shear Test
The SPT (N value) is the sum of the last two blow values in each sampling zone (AASHTO T206) The Unit Dry Weight (pcf) is noted in Italics above moist (%)
NR-No Recovery

TYL INTERNATIONAL

DESIGNED	- DE
CHECKED	- SP
DRAWN	- DE
CHECKED	- PF

DATE: 02-23-2005

BORING LOGS

MOFFETT ROAD OVER
DRAINAGE RAVINE
FAU 2758
LAKE COUNTY
S.N. 049-6803

STATE OF ILLINOIS
DEPARTMENT OF TRANSPORTATION

SB-2

PAGE 1 of 2
DATE April 28, 2004
LOGGED BY TOB
OBA JOB No. 03356

OBA
O'BRIEN & ASSOCIATES, INC.
CONSULTING ENGINEERS
2281 S. DAVIS ST., ARLINGTON HTS., IL 60005
(847) 398-4441 • FAX (847) 398-2376

SOIL BORING LOG

ROUTE FAP Rt. 330 DESCRIPTION Moffett Road Bridge Over Un-Named Ravine
SECTION I28 R-2 LOCATION Lake Bluff, Illinois
COUNTY Lake DRILLING METHOD 3.25" Hollow Stem Auger HAMMER TYPE D-120 Safety

STRUCT. NO. 049-6801
Station 137+50.47 to 183+60.80
BORING NO. SB-2
Station: 138+76
Offset: 6' Right
Ground Surface Elev. 664.3

Description	Depth (ft)	Bulge (ft)	S-Shear (lb)	P-Penetrometer (lb)	ST-Shelby Tube Sample	VS-Vane Shear Test	UCS Failure Mode	
							(ft)	(%)
Surface Water Elev. 632.2								
Stream Bed Elev. n/a								
Groundwater Elevation:								
First Encounter 638.3								
Upon Completion 601.3								
After Hrs.								
5.5' ASPHALT	21							
CRUSHED STONE & CONCRETE- very dense (FIII)	50/5'							
	NP 5							
	44/5'							
SILT-gray-very dense (A-4)	-5							
	NP 6							
SAND-gray-medium dense (A-1-b)	50/5'							
	NP 7							
CRUSHED STONE SCREENINGS- very dense (FIII)	50/4'							
	NP 10							
CLAY-brown & gray- hard (CL)	8							
	4							
CLAY-gray- very stiff to hard (A-6)	2							
	5.0B 15							
CLAY-gray- very stiff to hard (CL)	7							
	11.3							
	7							
	17							
	-15							
	10							
	3							
	11.5							
	6							
	7							
	5							
	11.7							
	8							
	13							
	-20							
	16							

The Unconfined Compressive Strength (UCS) Failure Mode is Indicated by (B-Bulge, S-Shear, P-Penetrometer) ST-Shelby Tube Sample VS-Vane Shear Test
The SPT (N value) is the sum of the last two blow values in each sampling zone (AASHTO T206) The Unit Dry Weight (pcf) is noted in Italics above moist (%)
NR-No Recovery

SB-2

PAGE 2 of 2
DATE April 28, 2004
LOGGED BY TOB
OBA JOB No. 03356

OBA
O'BRIEN & ASSOCIATES, INC.
CONSULTING ENGINEERS
2281 S. DAVIS ST., ARLINGTON HTS., IL 60005
(847) 398-4441 • FAX (847) 398-2376

SOIL BORING LOG

ROUTE FAP Rt. 330 DESCRIPTION Moffett Road Bridge Over Un-Named Ravine
SECTION I28 R-2 LOCATION Lake Bluff, Illinois
COUNTY Lake DRILLING METHOD 3.25" Hollow Stem Auger HAMMER TYPE D-120 Safety

STRUCT. NO. 049-6801
Station 137+50.47 to 183+60.80
BORING NO. SB-2
Station: 138+76
Offset: 6' Right
Ground Surface Elev. 664.3

Description	Depth (ft)	Bulge (ft)	S-Shear (lb)	P-Penetrometer (lb)	ST-Shelby Tube Sample	VS-Vane Shear Test	UCS Failure Mode	
							(ft)	(%)
Surface Water Elev. 632.2								
Stream Bed Elev. n/a								
Groundwater Elevation:								
First Encounter 638.3								
Upon Completion 601.3								
After Hrs.								
CLAY-gray- very stiff to hard (A-6)	6							
SILTY LOAM to SILT- gray-very dense (A-4)	11.3							
	75/5'							
CLAY-gray- very stiff to hard (CL)	8							
	13							
End of Boring @ -65.0' Hollow Stem Augers D-120 Safety Hammer	-45							
	17							
Drillers Observations: Blow-in sands @ -50.0'	10							
	11.3							
SILTY LOAM to SILT- gray-very dense (A-4)	15							
	17							
	-50							
	18							
	10							
	11.3							
	12							
	17							
	-55							
	16							
	9							
	11.4							
	13							
	17							
	-60							
	10							

The Unconfined Compressive Strength (UCS) Failure Mode is Indicated by (B-Bulge, S-Shear, P-Penetrometer) ST-Shelby Tube Sample VS-Vane Shear Test
The SPT (N value) is the sum of the last two blow values in each sampling zone (AASHTO T206) The Unit Dry Weight (pcf) is noted in Italics above moist (%)
NR-No Recovery

TYL INTERNATIONAL

DESIGNED	- DE
CHECKED	- SP
DRAWN	- DE
CHECKED	- PF

DATE: 02-23-2005

BORING LOGS

MOFFETT ROAD OVER
DRAINAGE RAVINE
FAU 2758
LAKE COUNTY
S.N. 049-6803