

INSIDE ELEVATION MEDIAN BARRIER

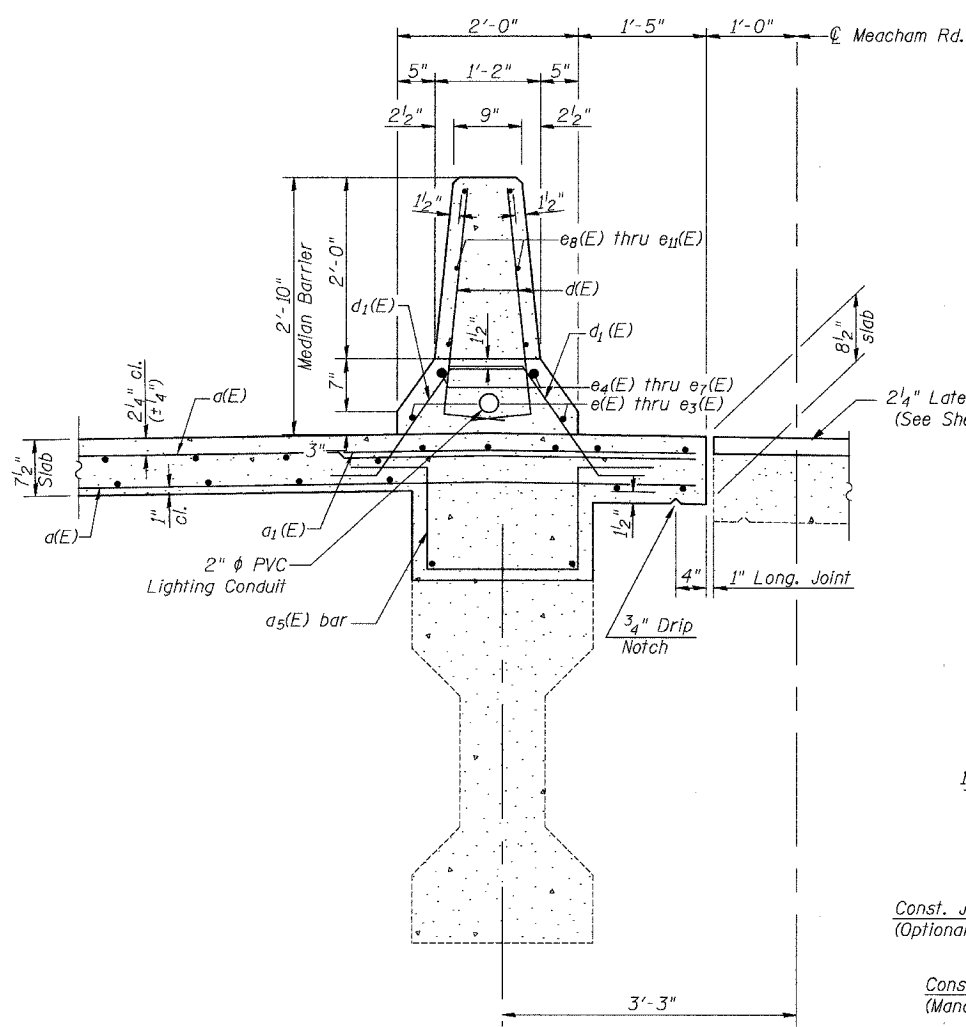

SECTION THRU MEDIAN BARRIER

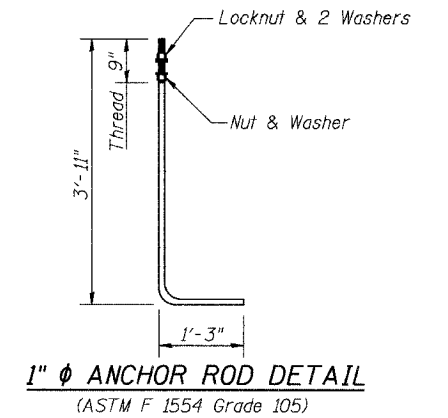
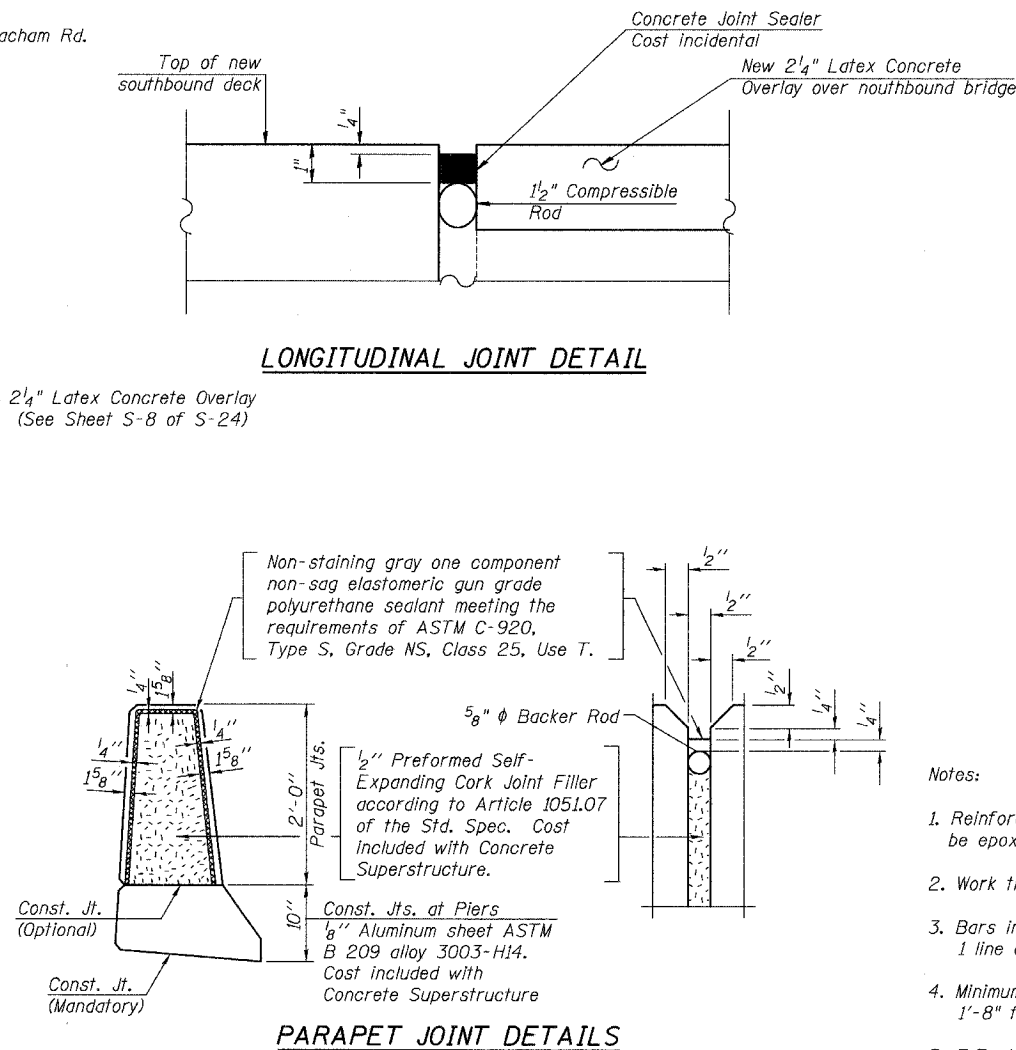

PARAPET JOINT DETAILS

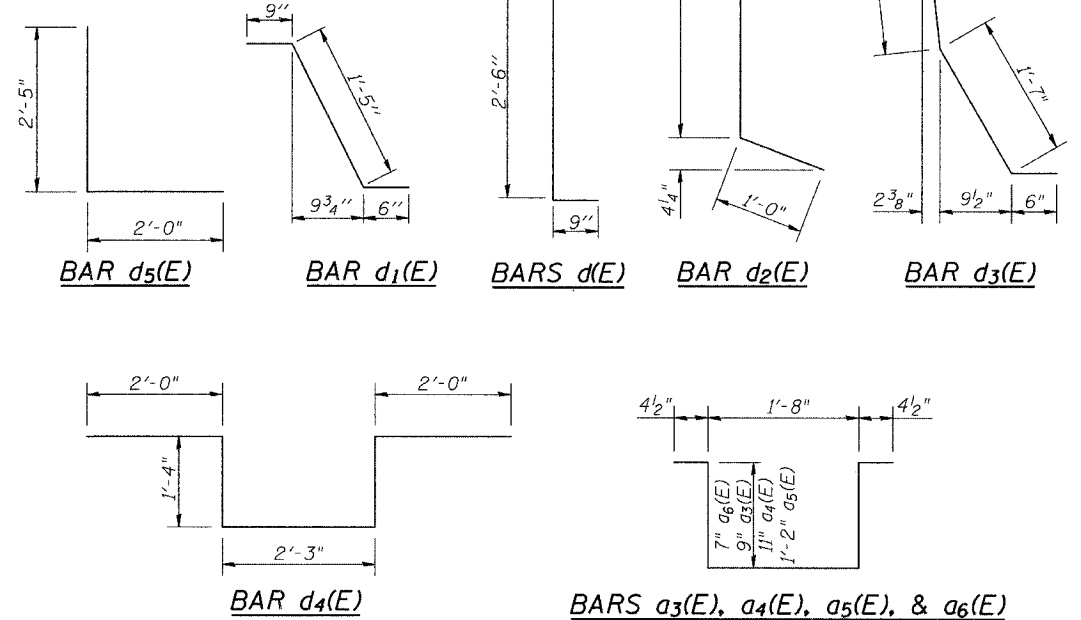

Notes:

1. Reinforcement bars designated (E) shall be epoxy coated.
2. Work this sheet with S-2, S-7, and S-9.
3. Bars indicated thus 1 x 2-#5 etc. indicates 1 line of bars with 2 lengths per line.
4. Minimum lap shall be 1'-4" for #4 bars, 1'-8" for #5 bars, and 3'-5" for #8 bars.
5. E.F. denotes Each Face.
6. I.F. denotes Inside Face.
7. O.F. denotes Outside Face.

DECK AND PARAPET DETAILS II  
 MEACHAM ROAD OVER NORTHWEST TOLLWAY  
 F.A.U. ROUTE 2585 SECTION 05-00068-02-BR  
 COOK COUNTY  
 STA. 285 + 04.18

STRUCTURE NO. 016-0676

MACTEC  
 DESIGNED: SCHELBAN/AYARGICOLU  
 DRAWN: SCHELBAN/AYARGICOLU  
 CHECKED: RLEE