

F.A.P. RTE.	SECTION	COUNTY	TOTAL SHEETS	SHEET NO.
317	***	FULTON	684	24
STA.		TO STA.		
FED. ROAD DIST. NO.		ILLINOIS	FED. AID PROJECT	
***181,188BY&189RY-1BR,188-1				

LEGEND

- ① EXISTING P. C. C. PAVEMENT
- ② EXISTING BITUMINOUS OVERLAY
- ③ EXISTING AGGREGATE SHOULDER
- ④ EXISTING P. C. C. GUTTER TYPE A OR TYPE B (MOD.)
- ⑤ EXISTING BASE COURSE WIDENING
- ⑬ PROPOSED SAW CUT (PAID FOR AS "SAW CUTTING" - FT)
- ⑭ EARTH EXCAVATION (WIDENING) (CU YD)
- ⑰ PROPOSED BIT. SURFACE REMOVAL (COLD MILLING) 1/4" ***
- ⑱ PROPOSED PAVEMENT REMOVAL (SQ YD)
- ⑲ PROPOSED STRIP REFLECTIVE CRACK CONTROL (FT)
- ⑳ PROPOSED LIME-MODIFIED SOIL (SQ YD)
- ㉑ PROPOSED SUB-BASE GRANULAR MATERIAL, TYPE B (SQ YD) OR (TONS)
- ㉒ PROPOSED SUB-BASE GRANULAR MATERIAL, TYPE C (TONS)
- ㉓ PROPOSED AGGREGATE BASE COURSE, TYPE B 8" (SQ YD)
- ㉔ PROPOSED AGGREGATE SHOULDER TYPE B 6" (TONS)
- ㉕ PROPOSED AGGREGATE SHOULDER TYPE B - VAR DEPTH (TONS)
- ㉖ PROP. TOPSOIL EXCAVATION & PLACEMENT 4" & CLASS 2A SEEDING
- ㉗ PROPOSED AGGREGATE SURFACE COURSE, TYPE A 8" (TONS)
- ㉘ PROPOSED BITUMINOUS SHOULDER 6 1/2" (SQ YD)
- ㉙ PROPOSED BITUMINOUS SHOULDER 6" (SQ YD)
- ㉚ PROPOSED BIT. CONC. BINDER COURSE 8" (SQ YD)
- ㉛ PROPOSED BIT. CONC. BINDER COURSE 9" (SQ YD)
- ㉜ PROPOSED POLYMERIZED BIT. CONC. BINDER COURSE 2 1/4" (TONS)
- ㉝ PROPOSED POLYMERIZED BIT. CONC. SURFACE COURSE 2" SUPERPAVE, MIX "D", N70 (TONS)
- ㉞ PROPOSED POLYMERIZED BIT. CONC. SURFACE COURSE 1 1/2" SUPERPAVE, MIX "D", N70 (TONS)
- ㉟ PROPOSED P. C. C. BASE COURSE 7" (SQ YD)
- ㊱ PROPOSED BIT. SURFACE TREATMENT, CLASS A-3
- ㊲ PROPOSED GUARDRAIL AGGREGATE EROSION CONTROL (CA 1 - TONS)
- ㊳ PROPOSED STEEL PLATE BEAM GUARDRAIL, TYPE A
- ㊴ PROPOSED CABLE ROAD GUARD, SINGLE STRAND (PER STD 636001)
- ㊵ PROPOSED COMB. CONC. CURB & GUTTER TYPE M 4.06
- ㊶ PROPOSED GUTTER TYPE A (MODIFIED)
- ㊷ PROPOSED PAVED DITCH TYPE B-22 (STD 606401)
- ㊸ PROPOSED PAINT PAVEMENT MARKING - 4" WHITE
- ㊹ PROPOSED PAINT PAVEMENT MARKING - 4" YELLOW
- ㊺ NON-WOVEN GEOTECHNICAL FABRIC PER 1080.02 (INCL. IN COST OF ㉟)
- ㊻ PAVEMENT FABRIC
- ㊼ GEOTECHNICAL FABRIC FOR GROUND STABILIZATION (SQ YD)

*** SEE SPECIAL PROVISIONS
1/4" IS AT C

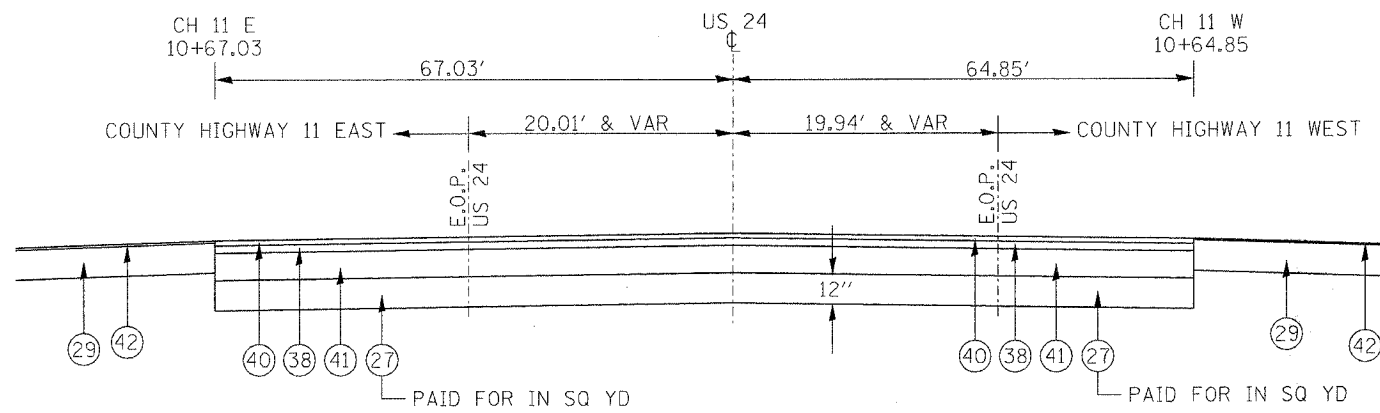

US 24 STA. 77+97 TO STA. 79+10
(THIS TYPICAL THROUGH C OF CH11 EAST & WEST)

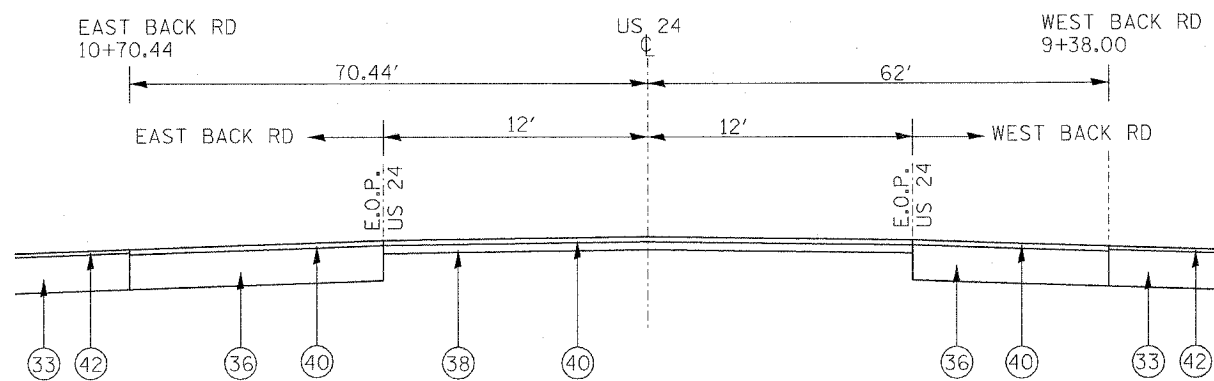

INTERSECTION OF US 24 & BACK RD
(THIS TYPICAL THROUGH C OF BACK RD, EAST & WEST)

REVISIONS	
NAME	DATE

ILLINOIS DEPARTMENT OF TRANSPORTATION

TYPICAL SECTIONS
FOR INTERSECTIONS

SCALE: VERT. / HORIZ. / DATE
DRAWN BY / CHECKED BY