

STATE OF ILLINOIS  
DEPARTMENT OF TRANSPORTATION

ROUTE NO.	SECTION	COUNTY	TOTAL SHEETS	SHEET NO.
FAP 315	(18BRY-1)BR	FULTON	46	21
FED. ROAD DIST. NO. 7	ILLINOIS	FED. AID PROJECT-		

Contract #88753

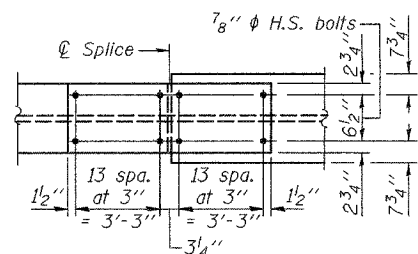

PLAN - SPLICES 1, 2 & 3  
(Top flange)

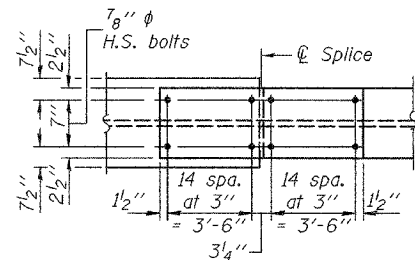

PLAN - SPLICE 4  
(Top flange)

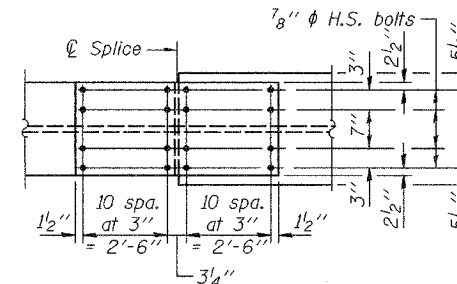

PLAN - SPLICE 5  
(Top flange)

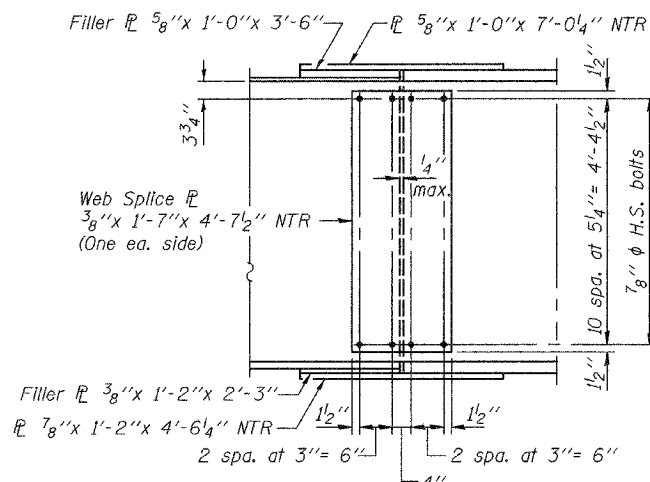

ELEVATION - SPLICES 1, 2 & 3

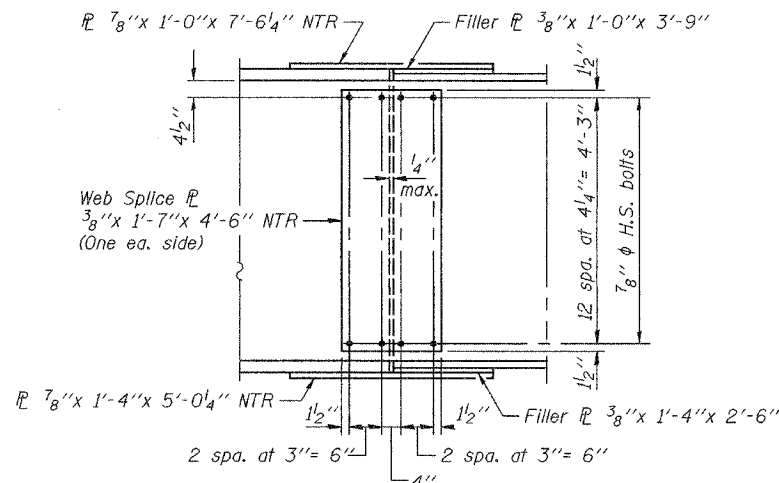

ELEVATION - SPLICE 4

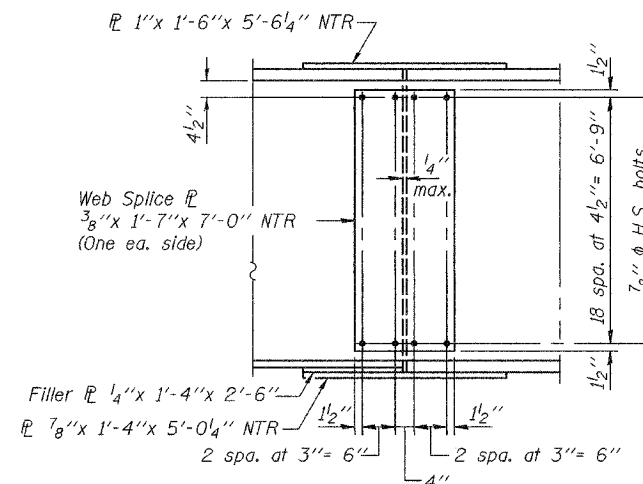

ELEVATION - SPLICE 5

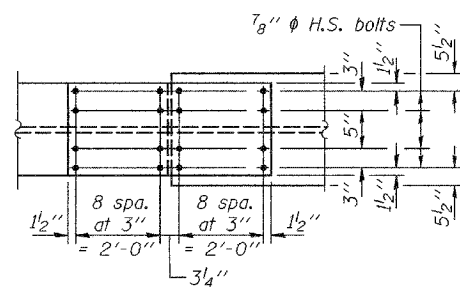

PLAN - SPLICES 1, 2 & 3  
(Bottom flange)

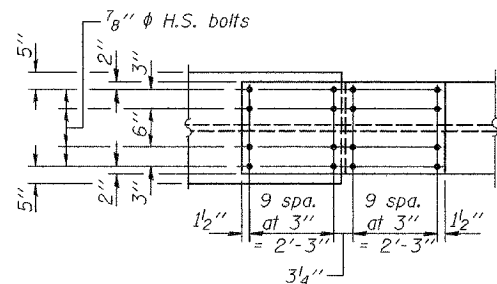

PLAN - SPLICE 4  
(Bottom flange)

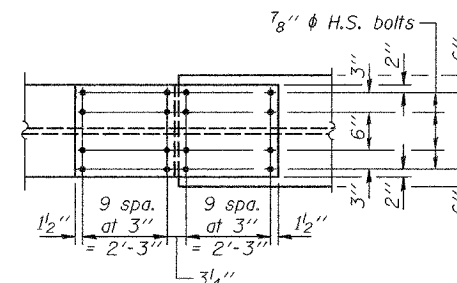

PLAN - SPLICE 5  
(Bottom flange)

Notes: "NTR" denotes plates to which notch toughness requirements are applicable.  
All splice plates shall be AASHTO M 270, Grade 50.

DESIGNED	MJT
CHECKED	FT
DRAWN	h.t. parsons
CHECKED	MJT/FT

May 16, 2005  
EXAMINED *Thomas J. Domagala*  
ENGINEER OF BRIDGE DESIGN  
PASSED *Ralph E. Anderson*  
ENGINEER OF BRIDGES AND STRUCTURES

\*TOP OF WEB ELEVATIONS

Location	¢ Brg. N. Abut.	¢ Splice 1	¢ Brg. Pier 1	¢ Splice 2	¢ Splice 3	¢ Brg. Pier 2	¢ Splice 4	¢ Splice 5	¢ Brg. Pier 3	¢ Splice 6	¢ Splice 7	¢ Brg. S. Abut.
Girder 1	475.187	476.358	476.728	477.080	478.303	478.637	478.971	480.090	480.901	481.825	483.683	483.882
Girder 2	475.426	476.599	476.969	477.321	478.544	478.878	479.212	480.330	481.145	482.073	483.938	484.121
Girder 3	475.665	476.840	477.209	477.561	478.784	479.118	479.451	480.568	481.385	482.315	484.181	484.360
Girder 4	475.904	477.079	477.448	477.800	479.023	479.356	479.689	480.806	481.625	482.556	484.424	484.599
Girder 5	476.144	477.320	477.689	478.040	479.262	479.596	479.930	481.045	481.865	482.797	484.666	484.839
Girder 6	476.383	477.555	477.926	478.278	479.501	479.834	480.167	481.283	482.101	483.032	484.895	485.078

\*For fabrication only

STRUCTURAL STEEL DETAILS  
F.A.P. RTE. 315 - SEC. (18BRY-1)BR  
FULTON COUNTY  
STATION 74+09.00  
STRUCTURE NO. 029-0068