

| REL.                  | SECTION                          | COUNTY               | TOTAL SHEETS | SHEET NO. |
|-----------------------|----------------------------------|----------------------|--------------|-----------|
| T.R. 274              | 03-10120-00-BR<br>03-18116-00-BR | FAYETTE              | 14           | 11        |
| FED. ROAD DIST. NO. 7 | BLANCK                           | FED. AID PROJECT NO. |              |           |

**NOTES**

Hollow structural steel tubing shall conform to the requirements of ASTM designation A-500 Grade B Structural Steel Tubing and shall meet the longitudinal CVN requirements of 15 ft.-lbs. at 0° F.

All other steel shapes and plates shall conform to the requirements of AASHTO M-270 Grade 36 except posts and angles shall conform to AASHTO M-270 Grade 50.

Bolts, cap screws, and nuts shall conform to the requirement of ASTM designation A-307 except for high strength bolts, nuts and washers noted which shall conform to AASHTO M-164.

All bolts, nuts, cap screws, washers and lock washers shall be galvanized in accordance with AASHTO M-232.

All posts, railing, rail splices, anchor devices and angles shall be galvanized after shop fabrication in accordance with AASHTO M-111 and ASTM A-385. Galvanized rail shall not be painted.

For multi-span bridges, sufficient 1/2" x 6" x 1'-2" galvanized steel shims shall be provided to align rail between adjacent spans. Cost incidental to Steel Railing, Type S-1.

All field drilled holes shall be coated with an approved zinc rich paint before erection.

The 1/2" x 7" x 6" plates that come in contact with concrete shall receive two coats of asphalt paint conforming to Section 760.07 Type II or place 1/8" fabric bearing pads between the plates and concrete.

The 3/4" high strength bolts used to connect the 6" x 4" x 3/4" angles to the post shall be tightened in accordance with Article 505.04 (f) (3) of the Standard Specifications. The 1" high strength bolts connecting the angles to the concrete shall be tightened to a snug fit and given an additional 1/8 turn. The 5/8" cap screws in bottom of posts shall be tightened to a snug fit only.

The maximum allowable rail post spacing shall be 10'-6". The rail post spacing shown elsewhere in the plans is based on the allowable spacing for another type of rail. When this type of rail is used, the number of posts may be decreased and the post spacing increased to provide equal post spaces of 10'-6" or less.

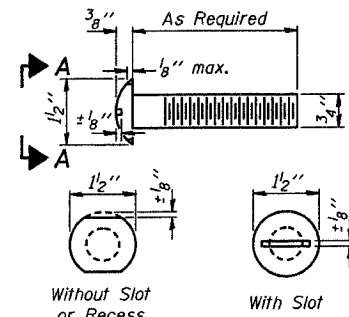

**VIEW A-A  
ROUND HEAD BOLT**

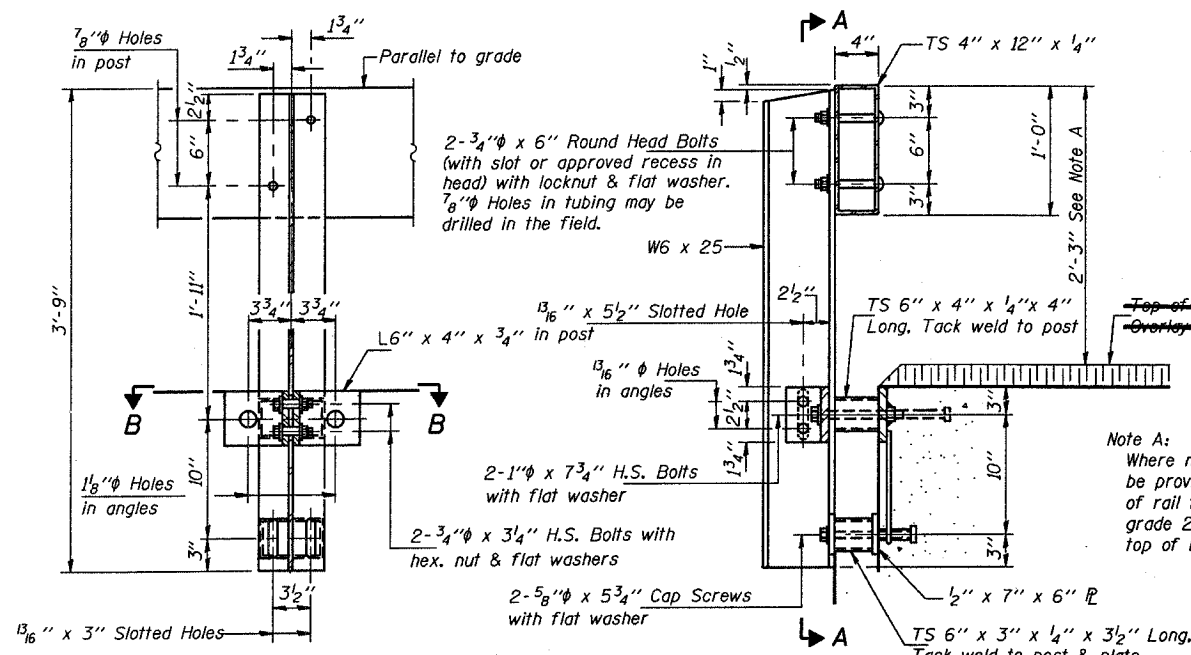

**SECTION A-A**

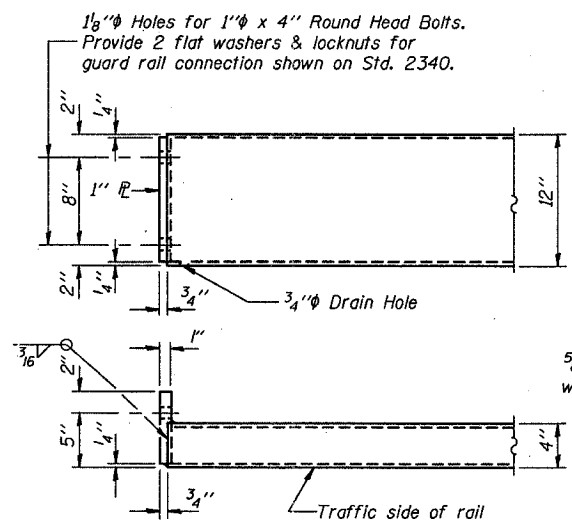

**END OF RAIL DETAILS**

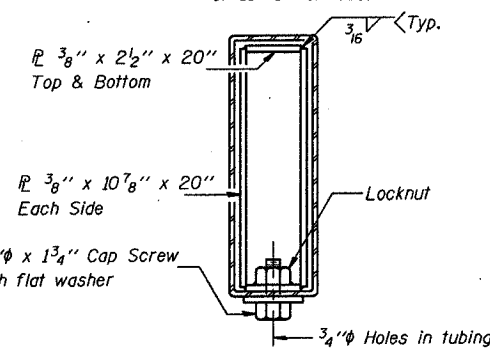

**SECTION AT RAIL SPLICE**

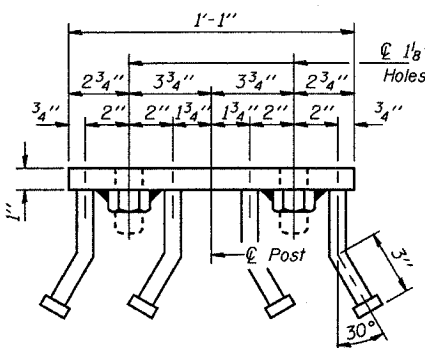

**VIEW C-C**

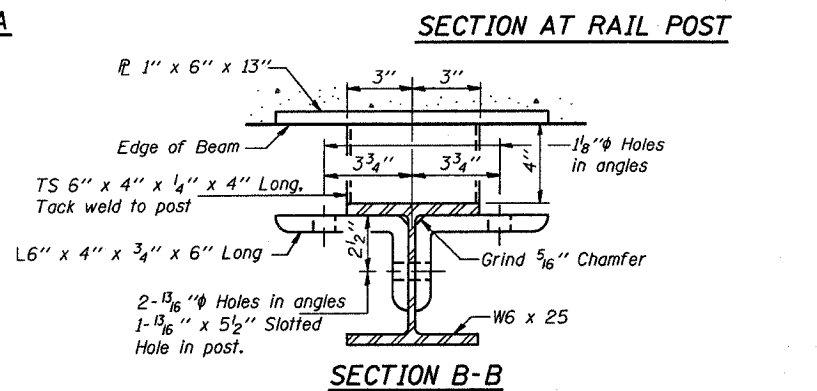

**SECTION B-B**

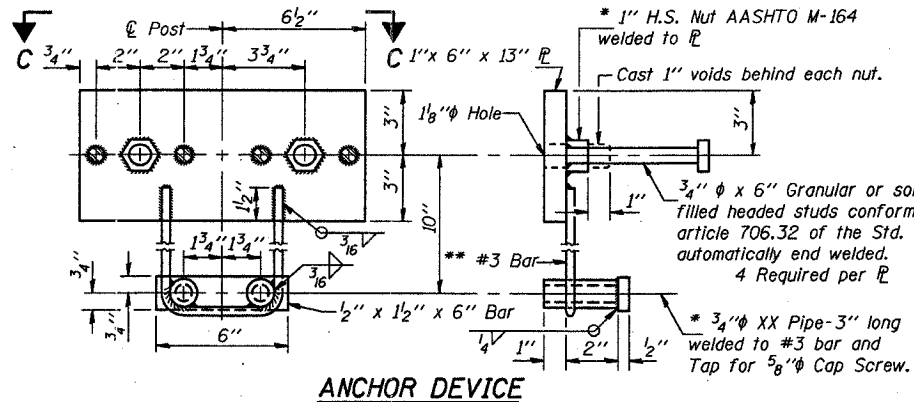

**ANCHOR DEVICE**

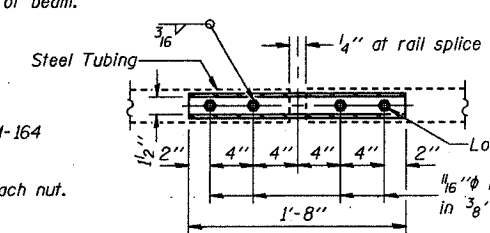

**PLAN-BOTT. SPLICE P  
TYPICAL**

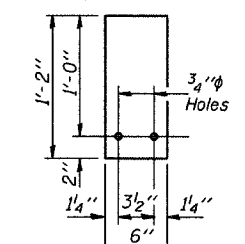

**1/4 SHIM PLATE**

Illinois Department of Transportation  
 PASSED November 1, 1995  
 Approved November 1, 1995  
 Engineer of Bridges and Structures

**STEEL RAILING, TYPE S-1  
STANDARD CR-TS1**