

TA001

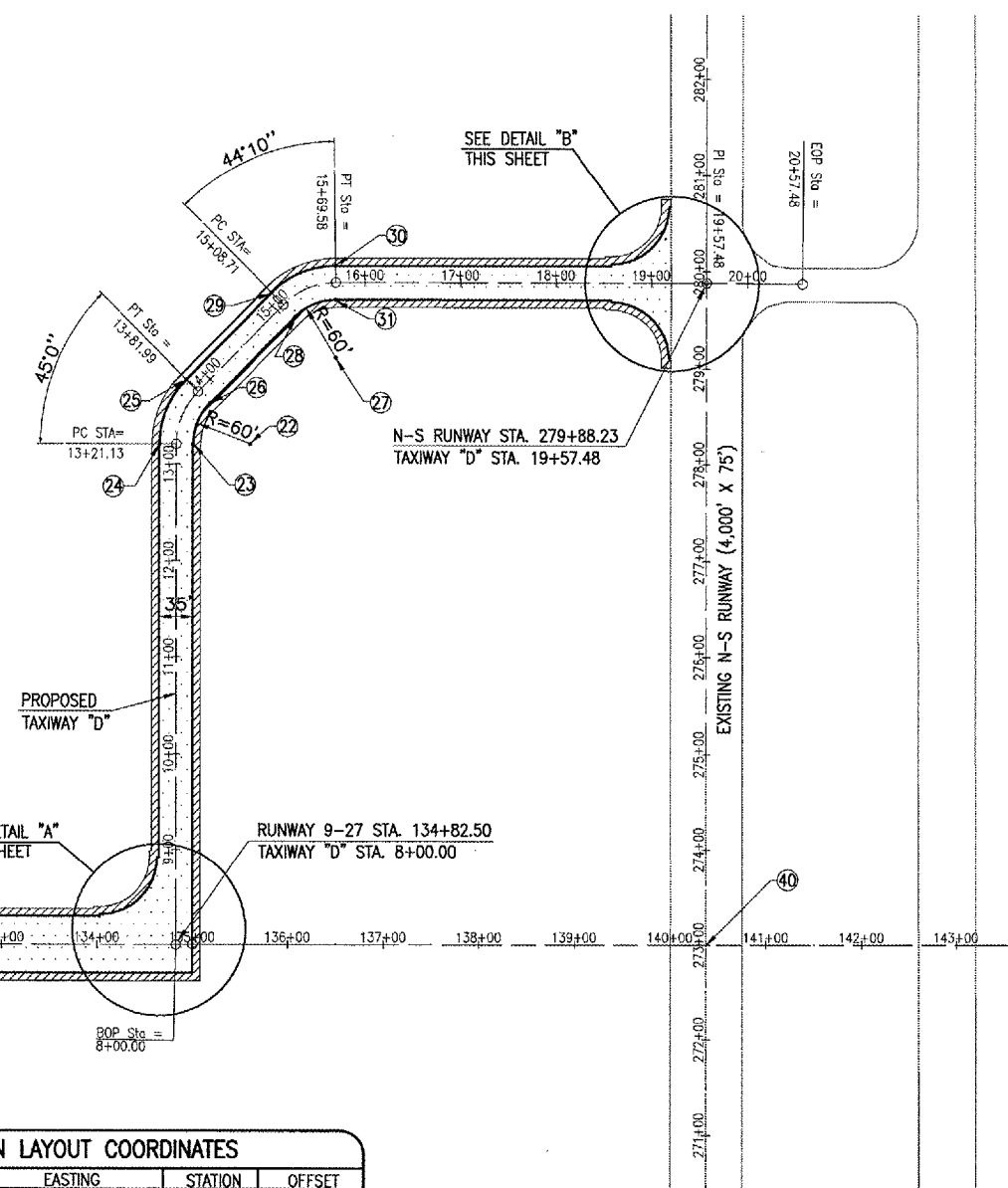

POINT NO.	NORTHING	EASTING	STATION	OFFSET
18	1043686.2544	2532773.3203	135+00.00	30.00' RT.
19	1043744.1868	2532675.0714	134+03.00	30.00' LT.
20	1043806.1729	2532673.7585	134+03.00	90.00' LT.
21	1043807.4859	2532735.7446	8+92.00	17.50' LT.
22	1044238.5265	2532821.6358	13+21.13	77.50' RT.
23	1044237.2559	2532761.6493	13+21.13	17.50' RT.
24	1044236.5147	2532726.6571	13+21.13	17.50' LT.
25	1044304.2640	2532753.0532	13+81.99	17.50' LT.
26	1044280.0449	2532778.3205	13+81.99	17.50' RT.
27	1044330.0054	2532909.3198	15+08.71	77.50' RT.
28	1044371.5239	2532866.0045	15+08.71	17.50' RT.
29	1044395.7429	2532840.7372	15+08.71	17.50' LT.
30	1044424.9784	2532907.0556	15+69.58	17.50' LT.
31	1044389.9920	2532908.0492	15+69.58	17.50' RT.
32	1044334.1153	2533197.7968	18+58.08	79.50' RT.
33	1044396.1014	2533196.4838	18+58.08	17.50' RT.
34	1044335.4321	2533259.9635	19+20.26	79.50' RT.
35	1044493.0796	2533194.4297	18+58.08	79.50' LT.
36	1044431.0935	2533195.7427	18+58.08	17.50' LT.
37	1044494.3936	2533256.4653	19+20.13	79.50' LT.
38	1044415.7024	2533295.4901	19+57.48	CENTERLINE
39	1043716.2477	2532772.8500	135+00.00	CENTERLINE
40	1043727.6301	2533310.0644	140+37.50	CENTERLINE

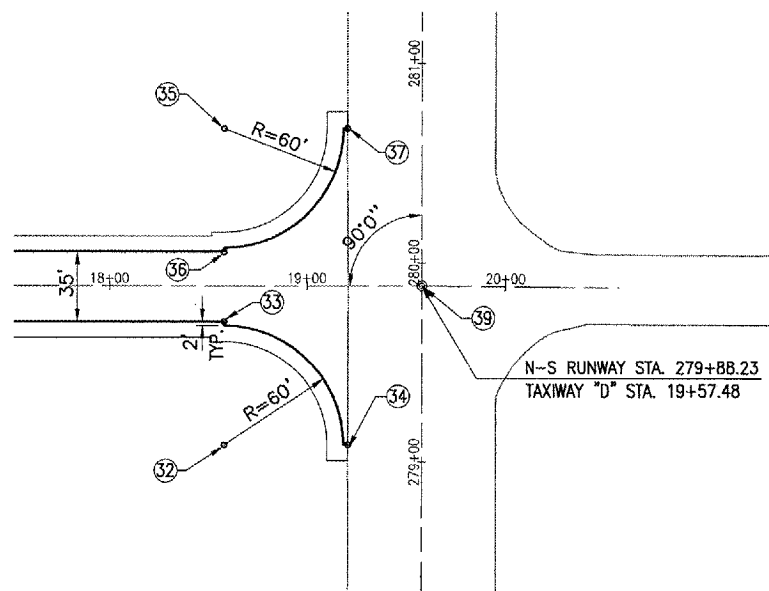
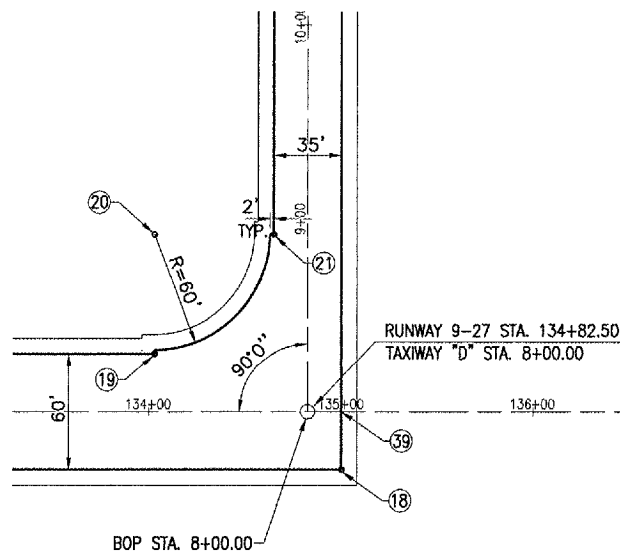
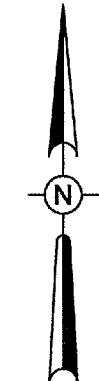
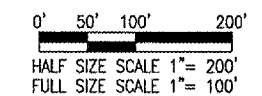
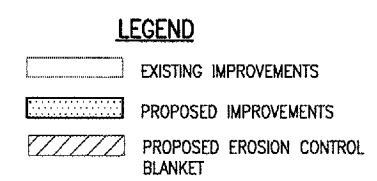

DATE	REVISION	BY

TAYLORVILLE MUNICIPAL AIRPORT  
TAYLORVILLE, ILLINOIS

IL. PROJ.: TAZ-3166 A.I.P. PROJ.: 3-17-0100-87

LAYOUT	RAW	02/05/04
DRAWN	MDR	03/25/05
REVIEWED	CAH	03/28/05



CONSTRUCT  
RUNWAY 9-27

PROPOSED  
CONSTRUCTION PLAN  
STA. 116+00 TO STA. 135+00

MAY 04, 2005 10:42 AM RAW  
I:\AIRPORTS\TAYLORVILLE\B28-03RWYGD\AIRPORT\SHEETS\R-12\CON.DWG - STA. 116+00 TO STA. 135+00