

P-13 IRVING PARK ROAD
STA. 4+06.69 TO STA. 6+21.53

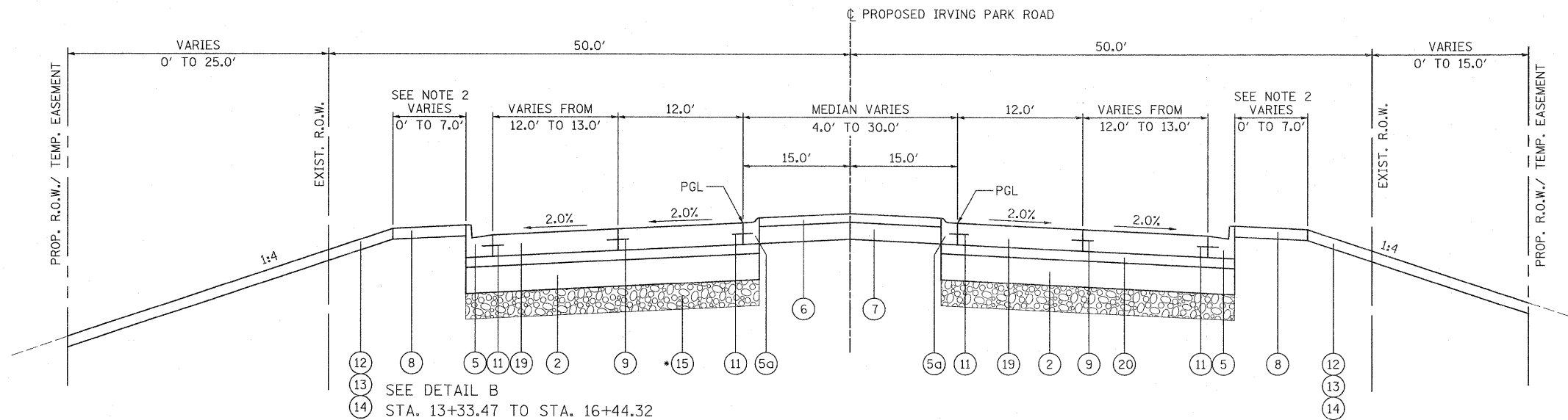

P-14 IRVING PARK ROAD
STA. 6+21.53 TO STA. 11+19.79
STA. 21+54.00 TO STA. 25+00.00

* PGE SUBGRADE 12" FROM:
STA. 20+50.00 TO STA. 24+45.00

LEGEND

- PROPOSED**
- ① PCC PAVEMENT 10" (JOINTED)
 - ② AGGREGATE SUBGRADE 12"
 - ③ CONCRETE MEDIAN, TYPE SB-6.18 (MODIFIED) (SEE DETAIL A)
 - ④ COMBINATION CONCRETE CURB AND GUTTER, TYPE B-6.18
 - ⑤ COMBINATION CONCRETE CURB AND GUTTER, TYPE B-6.24
 - ⑤a COMBINATION CONCRETE CURB AND GUTTER, TYPE M-2.12
 - ⑥ CONCRETE MEDIAN SURFACE, 4 INCH
 - ⑦ AGGREGATE BACKFILL (INCLUDED IN THE COST OF CONCRETE MEDIAN SURFACE)
 - ⑧ PORTLAND CEMENT CONCRETE SIDEWALK
 - ⑨ LONGITUDINAL CONSTRUCTION JOINT, NO. 8 EPOXY COATED TIE 24" LONG AT 24" CENTERS
 - ⑩ LONGITUDINAL SAWED JOINT, NO. 6 EPOXY COATED TIE BARS 30" BARS LONG AT 30" CENTERS
 - ⑪ LONGITUDINAL CONSTRUCTION JOINT, NO. 6 EPOXY COATED TIE BARS 24" LONG AT 24" CENTERS, DRILL AND GROUT (INCLUDED IN THE COST OF COMBINATION CONCRETE CURB AND GUTTER, CONCRETE MEDIAN AND CORRUGATED MEDIAN)
 - ⑫ EROSION CONTROL BLANKET (FOR USE ON ALL SEEDED AREAS)
 - ⑬ TOPSOIL FURNISH AND PLACE, - 4" (SEE NOTE 3)
 - ⑭ SODDING, SALT TOLERANT (SEE NOTE 3)
 - ⑮ POROUS GRANULAR EMBANKMENT, SUBGRADE
- PAVEMENT WIDENING AND RESURFACING
ARMY TRAIL ROAD AND IRVING PARK ROAD**
- ⑮ POLYMERIZED HOT-MIX ASPHALT SURFACE COURSE, MIX "F", N90 - 1 3/4"
 - ⑰ POLYMERIZED LEVELING BINDER (MACHINE METHOD), IL-4.75, N50 - 3/4"
 - ⑱ HOT-MIX ASPHALT BASE COURSE, 12 1/4"
- PAVEMENT WIDENING AND RESURFACING
(ALL OTHER SIDESTREETS)**
- ⑮ HOT-MIX ASPHALT SURFACE COURSE, MIX "D", N70 - 1 1/2"
 - ⑰ POLYMERIZED LEVELING BINDER (MACHINE METHOD), IL-4.75, N50 - 3/4"
 - ⑱ HOT-MIX ASPHALT BASE COURSE, 9 1/4"
 - ⑲ PORTLAND CEMENT CONCRETE PAVEMENT 10 1/4" (JOINTED)
 - ⑳ STABILIZED SUBBASE - HOT-MIX ASPHALT, 4 1/2"

NOTES:

1. SEE THE ROADWAY SCHEDULES AND PLAN AND PROFILE SHEETS FOR THE LOCATION OF BARRIER MEDIAN, CONCRETE MEDIAN, TYPE SB-6.18 (MODIFIED), MOUNTABLE MEDIAN, AND CORRUGATED MEDIAN.
2. PROPOSED SIDEWALKS ARE LOCATED INTERMITTENTLY THROUGHOUT THE PROJECT. SEE PLAN AND PROFILE SHEETS FOR LOCATIONS.
3. SEE THE LANDSCAPING DETAIL SHEETS FOR THE LOCATIONS OF: TOPSOIL FURNISH AND PLACE, 4", 6", 8", 12", AND 24" SODDING, SALT TOLERANT SEEDING, CLASS 2A AND SEEDING, CLASS 4

PATRICK ENGINEERING INC. 4970 VARSITY DRIVE LISLE, IL 60532 patrickengineering.com	USER NAME = ckarsten@lisle_ri PLOT CONFIG = PDF(Gray_Large).plt PLOT SCALE = 1:6.66667 PLOT DATE = 3/8/2011	DESIGNED - CPK DRAWN - ERC CHECKED - CPK DATE - 12/3/2010	REVISED - 03/11/2011 REVISED - REVISED - REVISED -	Illinois Department of Transportation	IRVING PARK ROAD PROPOSED TYPICAL SECTIONS		F.A. RTE. 2578 SECTION 532B COUNTY DUPAGE TOTAL SHEETS 781 SHEET NO. 57	CONTRACT NO. 60477
	SCALE: NA SHEET TYP-16 OF 22 STA. TO STA.				FED. ROAD DIST. NO. ILLINOIS FED. AID PROJECT			