

SIDE VIEW (TRUSS ARM)
N.T.S.

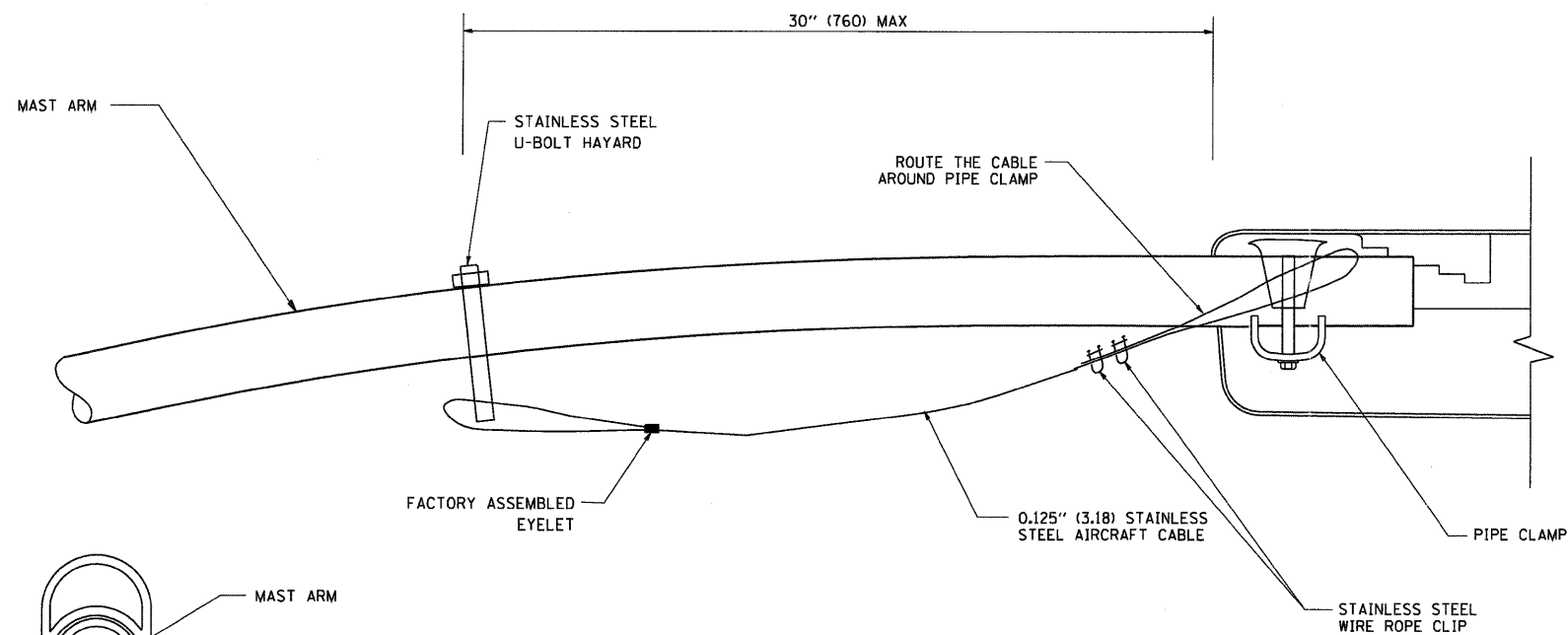

SIDE VIEW (SINGLE MEMBER OR DAVIT ARM)
N.T.S.

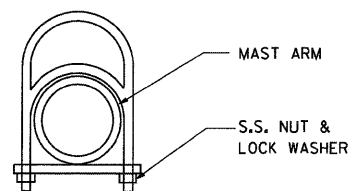

STAINLESS STEEL
U-BOLT HAYARD

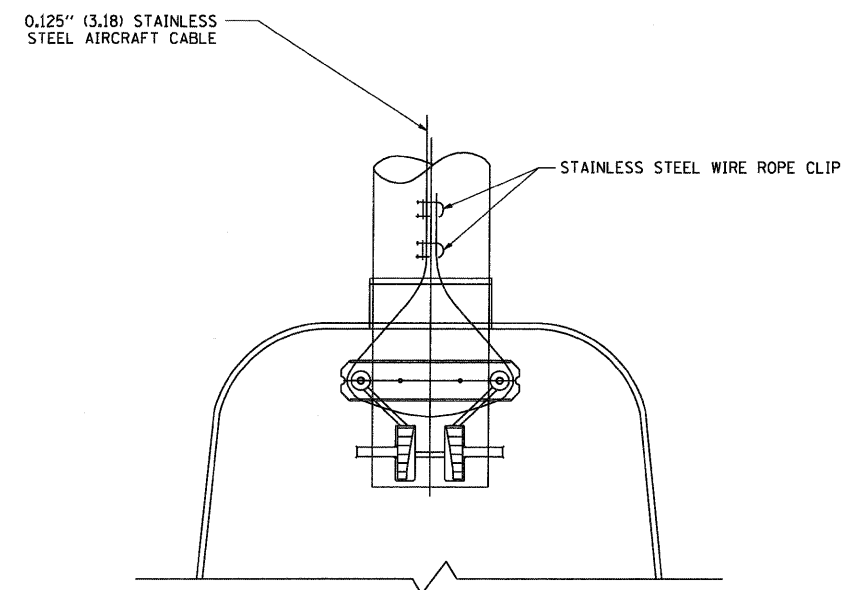

BOTTOM VIEW
N.T.S.

- NOTES:**
1. ALL DIMENSIONS ARE IN MILLIMETERS (INCHES) UNLESS OTHERWISE SHOWN.
 2. CONTRACTOR SHALL ADJUST THE WIRE CLIP TO ELIMINATE ANY SLACK FROM THE WIRE ROPE.
 3. THE 0.125" (3.18) STAINLESS STEEL AIRCRAFT CABLE SHALL REMAIN VISIBLE FROM THE GROUND LEVEL.
 4. THE BREAKING STRENGTH OF THE CABLE SHALL BE 1700 LBS. MIN.

FILE NAME = W:\diststd\22x34\be701.dgn	USER NAME = geglienobt	DESIGNED -	REVISED - 08-08-03	STATE OF ILLINOIS DEPARTMENT OF TRANSPORTATION	LUMINAIRE SAFETY CABLE ASSEMBLY			F.A. RTE.	SECTION	COUNTY	TOTAL SHEETS	SHEET NO.
	PLOT SCALE = 50.000' / IN.	DRAWN -	REVISED -		SCALE: NONE	SHEET NO. 1 OF 1 SHEETS	STA.	TO STA.	781	576		
	PLOT DATE = 1/4/2008	CHECKED -	REVISED -		BE-701		CONTRACT NO.		FED. ROAD DIST. NO. 1 ILLINOIS FED. AID PROJECT			
		DATE -	REVISED -									