

END ELEVATION
(West End Section)

* See section C-C for placement
** Measured normal to centerline of culvert

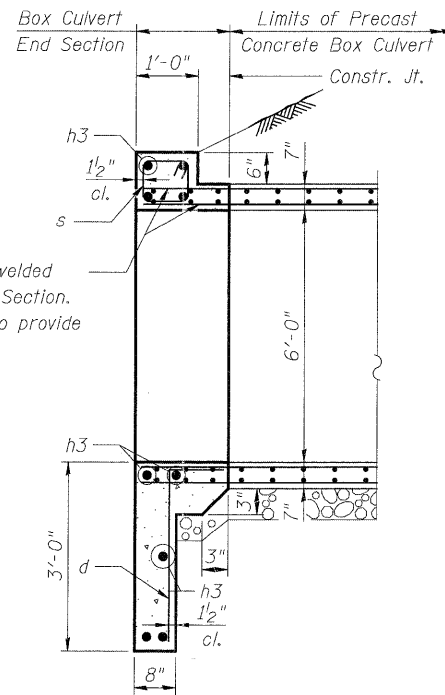

SECTION C-C

Extend precast box welded wire fabric into End Section. (Bend as necessary to provide 1/2" clear cover.)

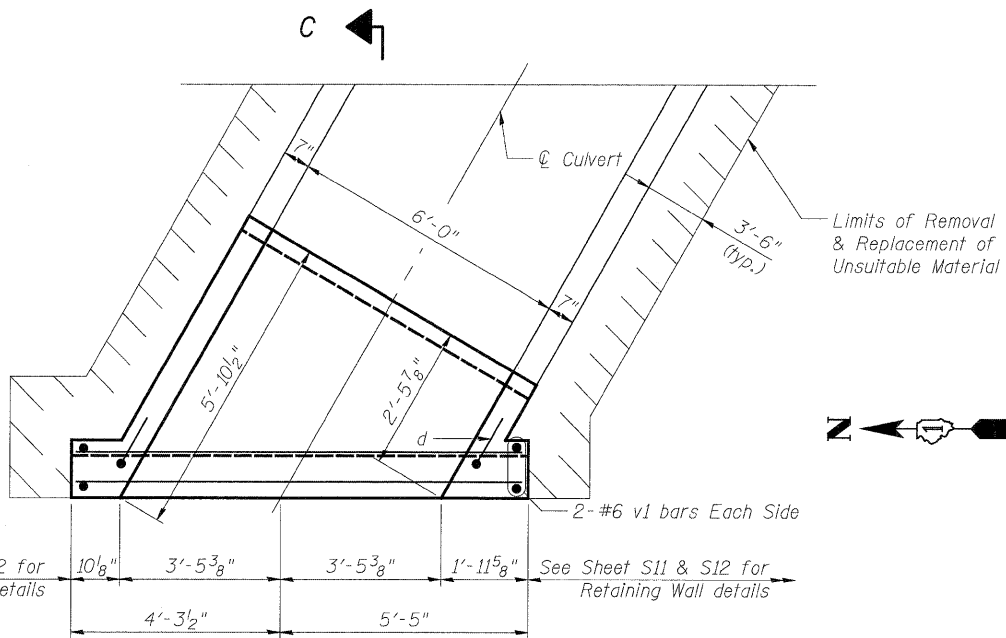

PLAN
(West End Section)

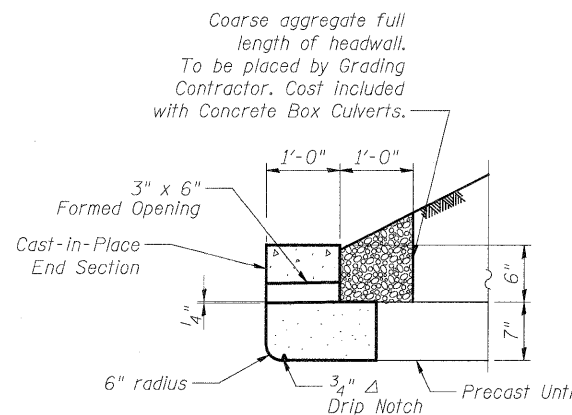

SECTION THRU HEADWALL
(West End Section)

DESIGNED	- A. Durbak
CHECKED	- R. DiGiulio
DRAWN	- A. Durbak
CHECKED	- R. DiGiulio

PATRICK ENGINEERING
PATRICK ENGINEERING INC.
4970 VARSITY DRIVE
LISLE, IL 60532
patrickengineering.com

SHEET NO. S7 OF S25	F.A.P. RTE. 2578	SECTION 532B	COUNTY DUPAGE	TOTAL SHEETS 781	SHEET NO. 586
	CONTRACT NO. 60477				
12/3/2010		ILLINOIS FED. AID PROJECT			

CULVERT DETAILS II
ILLINOIS ROUTE 53
FAU 2578 SECTION 532B-1
DUPAGE COUNTY STATION 176+91.55