

STATE OF ILLINOIS
DEPARTMENT OF TRANSPORTATION

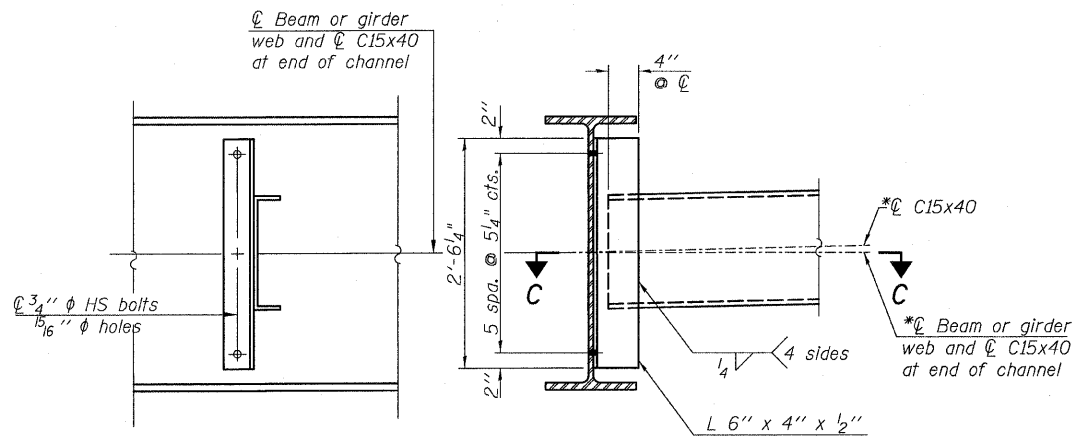

INTERIOR DIAPHRAGM

(D2.2)
(66 REQUIRED)

Note:
*Alternate channels C15x50 are permitted to facilitate material acquisition. Calculated weight of structural steel is based on the lighter section. The alternate, if utilized, shall be provided at no additional cost to the Department.

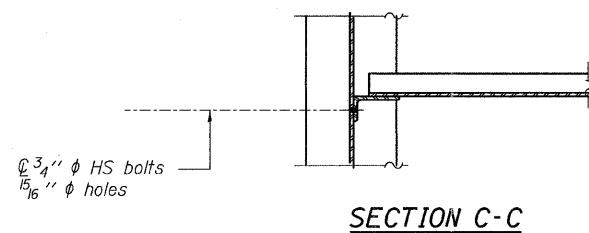

SECTION C-C

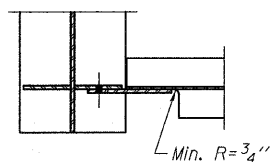

SECTION A-A

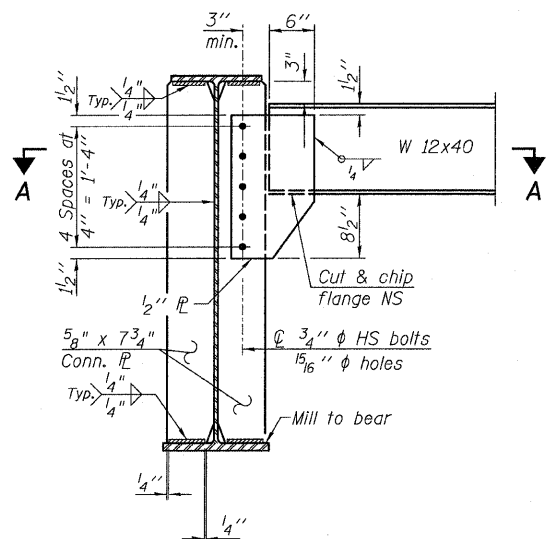

END DIAPHRAGM

(D2.1)
(6 REQUIRED)

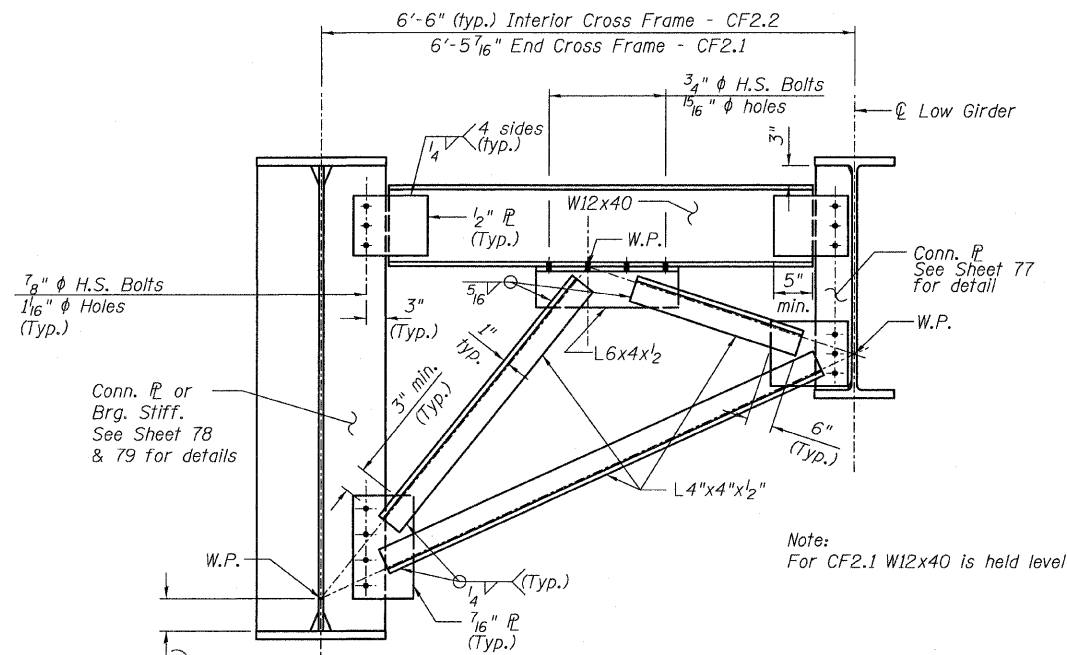

END CROSS FRAME CF2.1

(1 Required)

INTERIOR CROSS FRAME CF2.2

(4 Required)

Note:
For CF2.1 W12x40 is held level

NOTES:

- Two hardened washers shall be required over all oversize holes for diaphragms.
- All cross frames or diaphragms shall be installed as steel is erected and secured with erection pins and bolts except as otherwise noted. Individual cross frames or diaphragms at supports may be temporarily disconnected to install bearing anchor rods.
- All bolts shall be 3/4" φ with 15/16" φ holes unless otherwise noted.

**DIAPHRAGMS & DETAILS
RAMP 2 FLARE
STRUCTURE NO. 016-0724**

TYLIN INTERNATIONAL	DESIGNED - JPN	REVISIONS		SHEET NO. 149	F.A.I RTE.	SECTION	COUNTY	TOTAL SHEETS	SHEET NO.										
	CHECKED - AMD,	NAME	DATE							55	0711.2R & 1011.1BR	COOK	741	473					
	DRAWN - JMA														239 SHEETS	CONTRACT NO. 60999			
	CHECKED - AMD,																FED. ROAD DIST. NO. 1	ILLINOIS	FED. AID PROJECT
	DATE - 03/25/2011																		