

STATE OF ILLINOIS
DEPARTMENT OF TRANSPORTATION

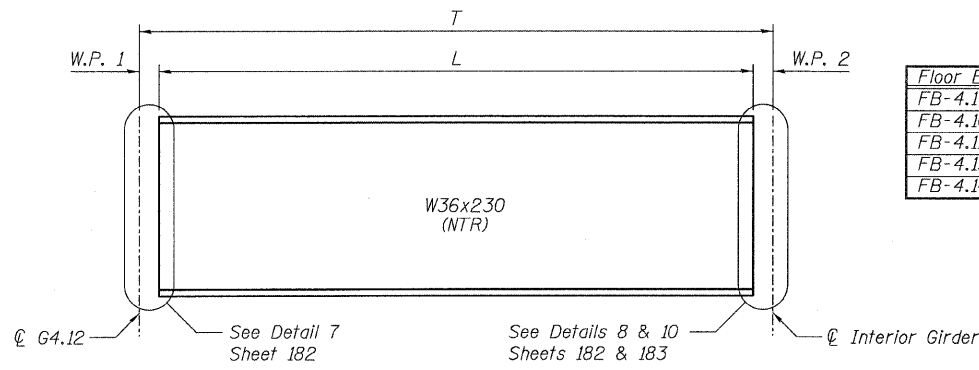

| Floor Beam | W.P. 1 | W.P. 2 | L | T |
|------------|-------------------------------------|---------------------------------|--------------------------------------|--------------------------------------|
| FB-4.1 | 1'-2 ⁵ / ₁₆ " | 6 ¹ / ₄ " | 7'-11 ¹ / ₁₆ " | 9'-8" |
| FB-4.10 | 1'-0 ¹ / ₂ " | 8 ¹ / ₄ " | 6'-6 ⁵ / ₁₆ " | 8'-3 ³ / ₁₆ " |
| FB-4.11 | 1'-0 ¹ / ₁₆ " | 8 ¹ / ₄ " | 3'-9 ⁵ / ₈ " | 5'-6 ⁵ / ₁₆ " |
| FB-4.13 | 1'-0 ⁹ / ₁₆ " | 8 ¹ / ₄ " | 6'-5 ⁵ / ₁₆ " | 8'-1 ¹ / ₈ " |
| FB-4.14 | 1'-0 ¹ / ₄ " | 8 ¹ / ₄ " | 5'-4 ⁵ / ₁₆ " | 7'-0 ¹³ / ₁₆ " |

FLOOR BEAM ELEVATION
(FB-4.1, FB-4.10, FB-4.11, FB-4.13, FB-4.14)

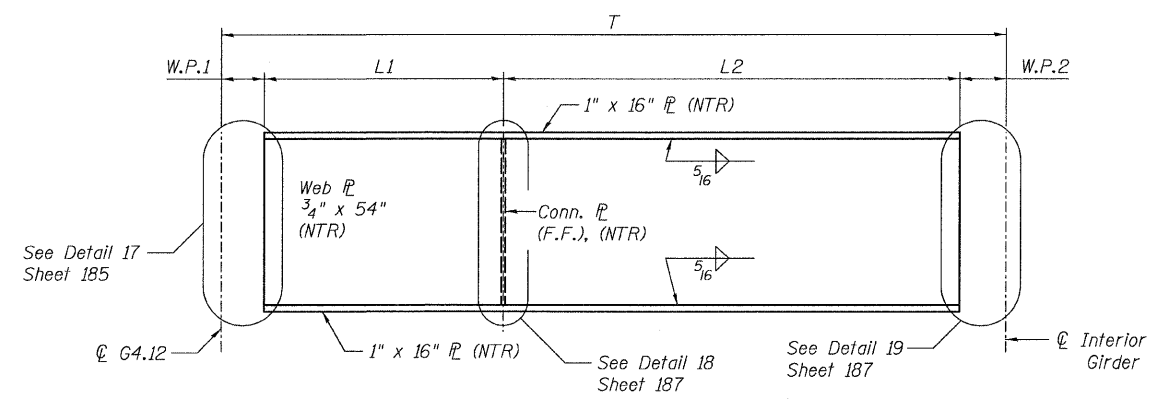

FLOOR BEAM ELEVATION
(FB-4.8, FB-4.9, FB-4.12)
(Looking West)

| Floor Beam | W.P. 1 | W.P. 2 | L1 | L2 | T | Conn. P |
|------------|--------------------------------------|---------------------------------|-------------------------------------|------------------------------------|---------------------------------------|--|
| FB-4.8 | 1'-0 ¹³ / ₁₆ " | 8 ¹ / ₄ " | 4'-10" | 5'-9 ³ / ₄ " | 12'-4 ¹³ / ₁₆ " | 5 ⁸ / ₁₆ " x 7 ³ / ₄ " |
| FB-4.9 | 1'-0 ⁹ / ₁₆ " | 8 ¹ / ₄ " | 4'-0 ¹ / ₁₆ " | 5'-9 ³ / ₄ " | 11'-6 ⁵ / ₈ " | 5 ⁸ / ₁₆ " x 7 ³ / ₄ " |
| FB-4.12 | 1'-0 ³ / ₈ " | 8 ¹ / ₄ " | 2'-3 ¹ / ₂ " | 5'-9 ³ / ₄ " | 9'-9 ¹ / ₈ " | 5 ⁸ / ₁₆ " x 7 ³ / ₄ " |

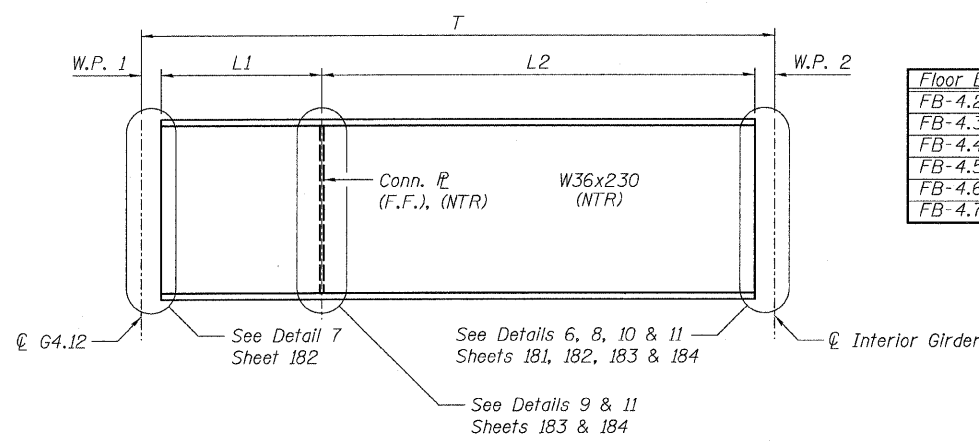

| Floor Beam | W.P. 1 | W.P. 2 | L1 | L2 | T | Conn. P |
|------------|-------------------------------------|---------------------------------|-------------------------------------|-------------------------------------|--------------------------------------|--|
| FB-4.2 | 1'-2 ¹ / ₁₆ " | 6 ¹ / ₄ " | 3'-2 ⁵ / ₁₆ " | 5'-11 ³ / ₄ " | 10'-11" | 5 ⁸ / ₁₆ " x 7 ³ / ₄ " |
| FB-4.3 | 1'-1 ¹ / ₈ " | 6 ¹ / ₄ " | 3'-2 ³ / ₈ " | 5'-11 ³ / ₄ " | 10'-10 ¹ / ₄ " | 5 ⁸ / ₁₆ " x 7 ³ / ₄ " |
| FB-4.4 | 1'-1 ¹ / ₁₆ " | 8 ¹ / ₂ " | 2'-2 ¹ / ₄ " | 5'-9 ¹ / ₂ " | 9'-9 ¹⁵ / ₁₆ " | 5 ⁸ / ₁₆ " x 7 ³ / ₄ " |
| FB-4.5 | 1'-1 ³ / ₈ " | 8 ¹ / ₂ " | 1'-10 ¹ / ₂ " | 5'-9 ¹ / ₂ " | 9'-5 ⁸ / ₁₆ " | 5 ⁸ / ₁₆ " x 7 ³ / ₄ " |
| FB-4.6 | 1'-1 ¹ / ₈ " | 8 ¹ / ₂ " | 2'-2 ¹ / ₁₆ " | 5'-9 ¹ / ₂ " | 9'-9 ¹⁵ / ₁₆ " | 5 ⁸ / ₁₆ " x 7 ³ / ₄ " |
| FB-4.7 | 1'-1" | 8 ¹ / ₄ " | 3'-2 ¹ / ₁₆ " | 5'-9 ³ / ₄ " | 10'-9 ¹ / ₁₆ " | 5 ⁸ / ₁₆ " x 7 ³ / ₄ " |

FLOOR BEAM ELEVATION
(FB-4.2 thru FB-4.7)
(Looking West)

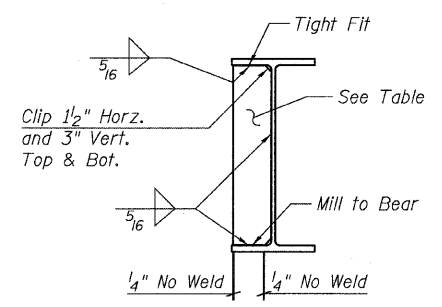

CONN. P DETAILS
(FB-4.2 to FB-4.7)

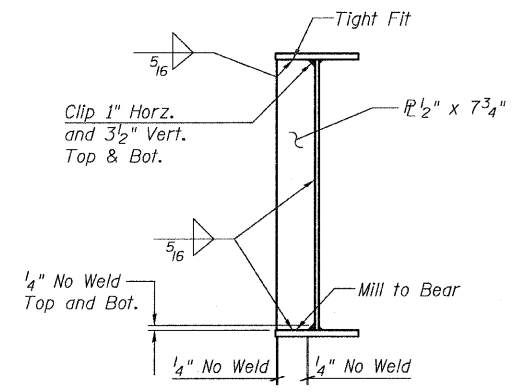

CONN. P DETAILS
(FB-4.8, FB-4.9, FB-4.12)

- NOTES:**
- All steel shown on this sheet shall conform to the requirements of AASHTO M270 GR 50.
 - Load carrying components designated "NTR" shall conform to the supplemental requirements for Notch Toughness, Zone 2.
 - F.F. denotes Far Face.

FLOOR BEAM DETAILS
RAMP 4 FLARE
STRUCTURE NO. 016-0724

| | | | | | | | | | |
|----------------------------|---------------------|-----------|------|---|---------------------|-------------------------------|----------------|------------------------|---------------------|
| TYLIN INTERNATIONAL | DESIGNED - EKH, JMA | REVISIONS | | SHEET NO. 178 | F.A.I RTE. 55 | SECTION 0711.2R & 1011.1BR | COUNTY COOK | TOTAL SHEETS 741 | SHEET NO. 502 |
| | CHECKED - AMD, | NAME | DATE | | | | | | |
| | DRAWN - EKH, JMA | | | | | | | | |
| | CHECKED - AMD, | | | | | | | | |
| | DATE - 03/25/2011 | | | | | | | | |
| | | | | 239 SHEETS | CONTRACT NO. 60999 | | | | |
| | | | | FED. ROAD DIST. NO. 1 ILLINOIS FED. AID PROJECT | | | | | |

5/10/2011 5:58:54 PM p:\01345\structure\2 Central Ave. 016-0724\5574 Framed\110.dgn