

STATE OF ILLINOIS
DEPARTMENT OF TRANSPORTATION

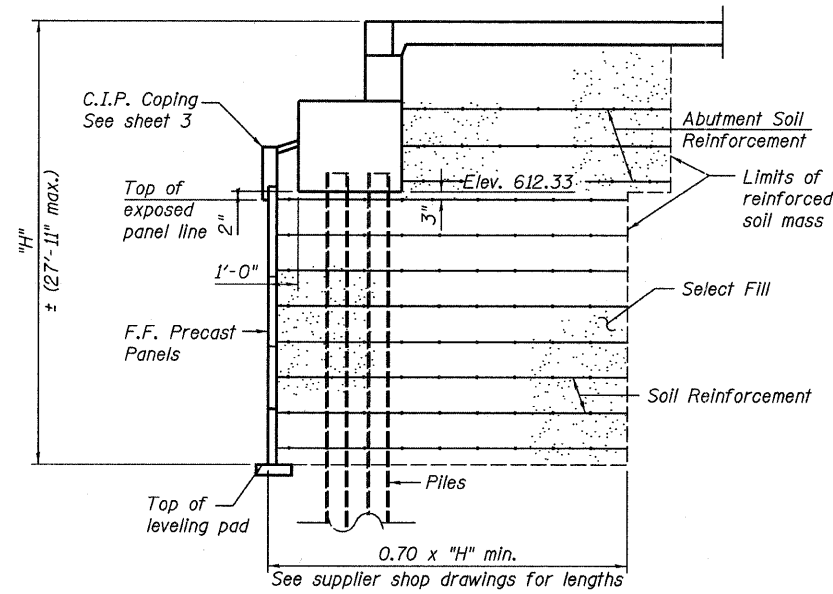

SECTION THRU ABUTMENT

NOTES

The MSE wall supplier shall design the abutment soil reinforcement to resist a horizontal force of 1.83 kips/ft of abutment.

Piles shall be driven prior to placement of the reinforced select fill and coated with coal tar epoxy from the bottom of the select fill to 1" above the base of abutment. The cost of the coal tar epoxy shall be included with the cost of furnishing piles. Cost of furnishing and driving piles is included with S.N. 016-0724.

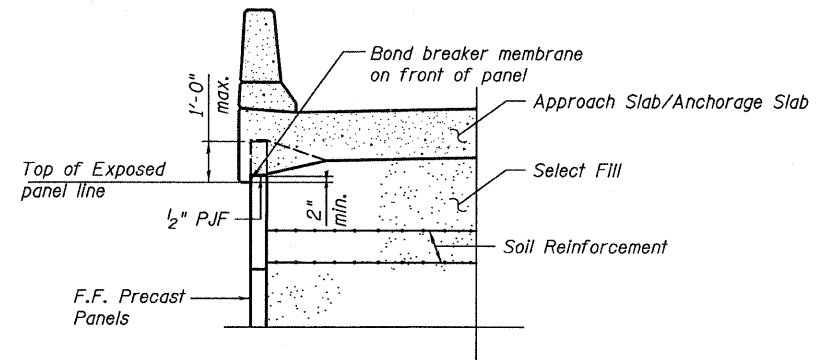

SECTION THRU RETAINING WALLS

NOTES

Offsets are to Front Face of precast panels.

For coping details see sheet 3.

For anchorage slab details, see sheets 6 & 7.

**RAMP 1 MSE ABUTMENT WALL SECTIONS
STRUCTURE NO. 016-1304**

TYLIN INTERNATIONAL	DESIGNED - JMA	REVISIONS		SHEET NO. 2	F.A.I. RTE.	SECTION	COUNTY	TOTAL SHEETS	SHEET NO.	
	CHECKED - AMD, MMB	NAME	DATE		55	0711.2R & 1011.1BR	COOK	741	565	
	DRAWN - JMA				CONTRACT NO. 60999					
	CHECKED - AMD, MMB				FED. ROAD DIST. NO. 1 ILLINOIS FED. AID PROJECT					
	DATE - 03/25/2011									

4/28/2011 1:29:22 PM p:\01345\structure\C2 Central Ave. 016-0724\55-1.mse.dgn