

STATE OF ILLINOIS
DEPARTMENT OF TRANSPORTATION

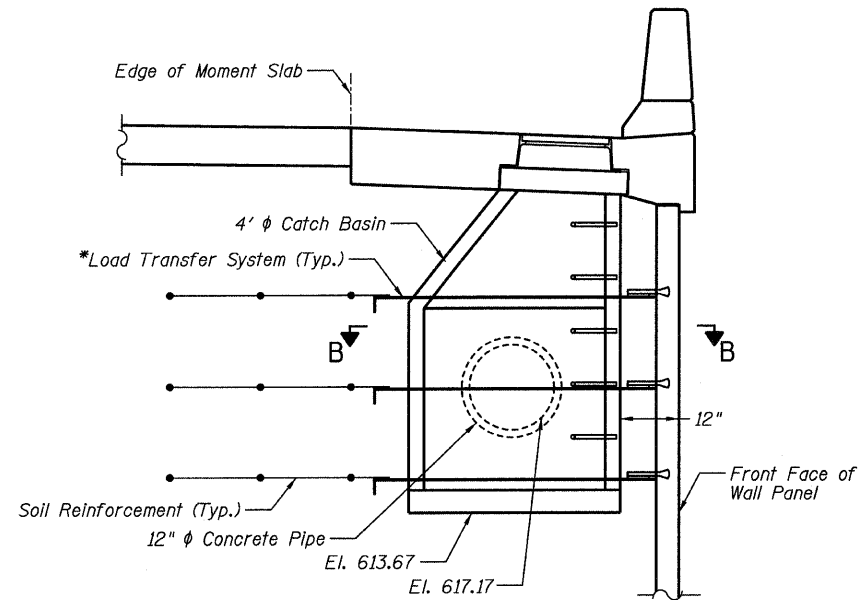

SECTION A-A

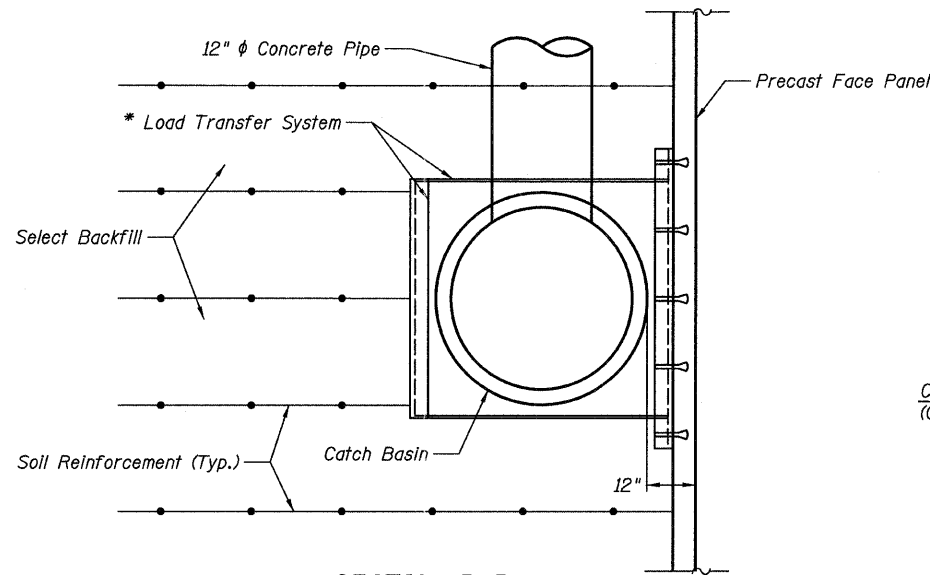

SECTION B-B

Note:
*M.S.E. supplier to design load transfer system to accommodate concrete pipe and catch basin.

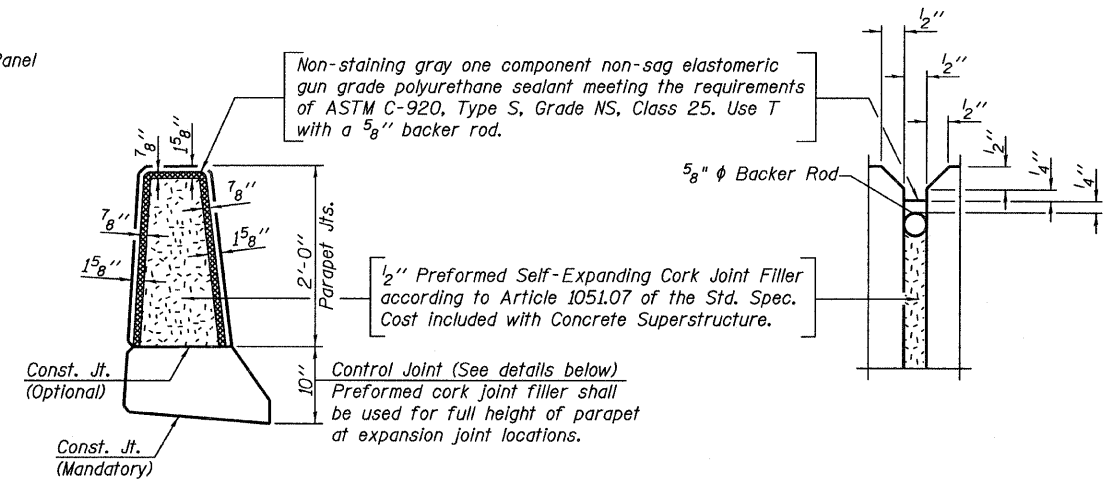

PARAPET JOINT DETAILS

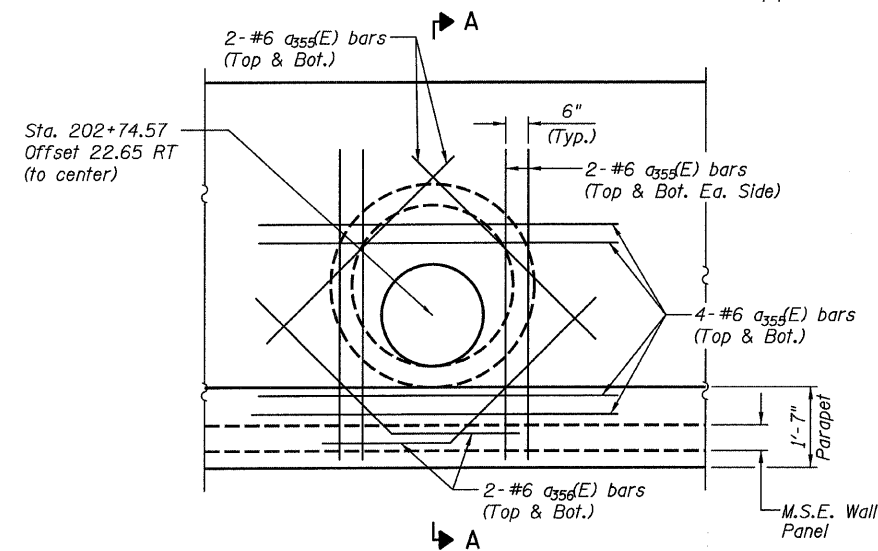

PLAN AT CATCH BASIN

1/4" wide x 1/2" deep sawed joint filled with hot poured sealant in accordance with Article 1050 of Standard Specifications.

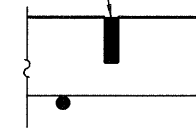

SAWED CONTRACTION JOINT DETAIL - SLAB
(Cost Included with Concrete Structures)

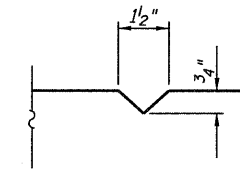

CONTROL JOINT DETAIL - PARAPET

RAMP 3 MOMENT SLAB
DETAILS
STRUCTURE NO. 016-1306

TYLIN INTERNATIONAL

DESIGNED - EKH	REVISIONS	
	NAME	DATE
CHECKED - AMD, MMB		
DRAWN - EKH		
CHECKED - AMD, MMB		
DATE - 03/25/2011		

SHEET NO. 6	F.A.I. RTE.	SECTION	COUNTY	TOTAL SHEETS	SHEET NO.
	55	0711.2R & 1011.1BR	COOK	741	589
9 SHEETS	CONTRACT NO. 60999				
FED. ROAD DIST. NO. 1 ILLINOIS FED. AID PROJECT					

p:\01345\structure\2_Central_Ave_016-0724\55-3\moms\lab01.dgn 4/28/2011 1:29:49 PM