

LEGEND

1. EXISTING COMBINATION CONCRETE CURB AND GUTTER
2. EXISTING P.C. CONCRETE BASE COURSE, ± 9"
3. EXISTING HMA SURFACE COURSE
4. EXISTING SAND CUSHION, 1"
5. EXISTING BRICK COURSE, 4"
6. EXISTING SUB-BASE GRANULAR MATERIAL, TYPE B, 4 1/2"
7. EXISTING CONCRETE CURB
8. EXISTING TOP SOIL AND SODDING, 4"
9. PROPOSED HMA SURFACE REMOVAL, 2 1/4"
10. PROPOSED POLYMERIZED LEVELING BINDER (MACHINE METHOD), IL-4.75, N50, 3/4"
11. PROPOSED HMA SURFACE COURSE, MIX "D", N70, 1 1/2"
12. PROPOSED AGGREGATE WEDGE SHOULDER, TYPE B (WHERE NECESSARY)
13. PROPOSED GRADING AND SHAPING SHOULDERS (WHERE NECESSARY)

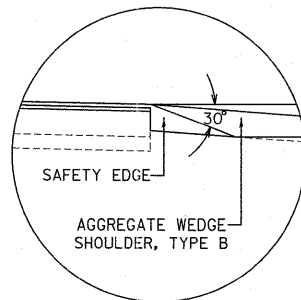

SAFETY EDGE DETAIL

NOTE

THE CONTRACTOR SHALL PATCH FIRST BEFORE MILLING
 * USE SAFETY EDGE DETAIL WHEN HMA SHOULDER IS 1' OR LESS (WHERE NECESSARY)

HOT-MIX ASPHALT MIXTURE REQUIREMENTS	
MIXTURE TYPE	AIR VOIDS(%)
PAVEMENT RESURFACING	
POLYMERIZED HMA SURFACE COURSE, MIX "D", N70 (IL-9.5 MM)	4% @ 70 GYR.
POLYMERIZED LEVELING BINDER COURSE (MM), IL-4.75, N50	4% @ 50 GYR.
PATCHING	
CLASS D PATCHES (HMA BINDER IL-25 mm)	4% @ 70 GYR.
HMA REPLACEMENT OVER PATCHES (HMA BINDER IL-19 mm)	4% @ 70 GYR.

NOTE 1: THE UNIT WEIGHT USED TO CALCULATE ALL HOT-MIX ASPHALT SURFACE MIXTURE QUANTITIES IS 112 LBS/SQ YD/IN.

NOTE 2: THE "AC TYPE" FOR POLYMERIZED HMA MIXES SHALL BE "SBS/SBR PG 70 -22 AND FOR NON-POLYMERIZED HMA THE "AC TYPE" SHALL BE "PG 64 -22" UNLESS MODIFIED BY DISTRICT ONE SPECIAL PROVISIONS.

FOR "PERCENT OF RAP" SEE DISTRICT ONE SPECIAL PROVISIONS.