

ROUTE	SECTION	COUNTY	TOTAL SHEETS	SHEET NUMBER
VARIOUS	2011-007-RS	LAKE	50	1

STATE OF ILLINOIS
DEPARTMENT OF TRANSPORTATION
DIVISION OF HIGHWAYS
DISTRICT ONE
PROPOSED HIGHWAY PLANS

CONTRACT NO. 60N95

D-91-438-11

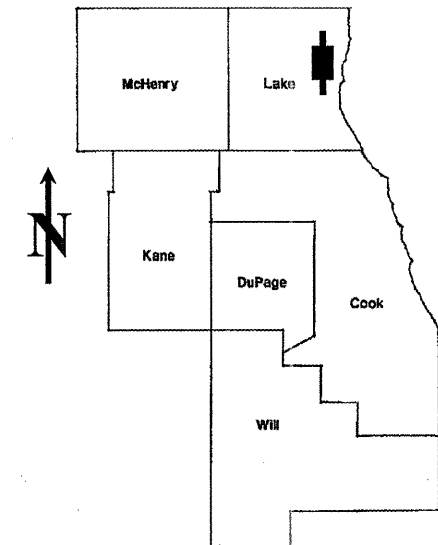

LOCATION OF IMPROVEMENT INDICATED THUS: 

VARIOUS ROUTES
 SECTION: 2011-007-RS
 VARIOUS LOCATIONS IN EAST LAKE COUNTY
 INTERMITTENT PAVEMENT RESURFACING
 LAKE COUNTY
 C-91-438-11

FOR INDEX OF SHEETS SEE SHEET 2

CONTRACT NO. 60N95

DISTRICT ONE - DESIGN - PLAN PREPARATION ENGINEER:
 KEN ENG / (847) 705-4247

STATE OF ILLINOIS
DEPARTMENT OF TRANSPORTATION
DIVISION OF HIGHWAYS

SUBMITTED: APRIL 6, 2011

Diana M. O'Keefe
 DEPUTY DIRECTOR OF HIGHWAYS, REGION ENGINEER

May 13 2011
Scott E. Stitt P.E.
 acting ENGINEER OF DESIGN AND ENVIRONMENT

May 13 2011
Christine M. Roeder
 DIRECTOR, DIVISION OF HIGHWAYS

PRINTED BY THE AUTHORITY
OF THE STATE OF ILLINOIS

J.U.L.I.E.: JOINT UTILITY LOCATION
INFORMATION FOR EXCAVATION
(312) 744-7000

INDEX OF SHEETS

STATE STANDARDS

GENERAL NOTES

SHEET NO.	DESCRIPTION	STANDARD NO.	DESCRIPTION
1	TITLE SHEET	000001-06	TYPICAL SYMBOLS, ABBREVIATIONS AND PATTERNS
2	INDEX OF SHEETS, STATE STANDARDS AND GENERAL NOTES	701011-02	OFF-RD MOVING OPERATIONS, 2L, 2W, DAY ONLY
3	SUMMARY OF QUANTITIES	701301-04	LANE CLOSURE, 2L, 2W, SHORT TIME OPERATIONS
4	GENERAL LOCATION MAP	701306-03	LANE CLOSURE, 2L, 2W, SLOW MOVING OPERATIONS - DAY ONLY
5	SUMMARY OF PATCHING SCHEDULE	701311-03	LANE CLOSURE 2L, 2W MOVING OPERATIONS - DAY ONLY
6-41	PATCHING SCHEDULE	701336-06	LANE CLOSURE, 2L, 2W, WORK AREAS IN SERIES
42	BUTT JOINT AND HMA TAPER DETAILS (BD-32)	701421-03	LANE CLOSURE, MULTILANE, DAY OPERATIONS ONLY, FOR SPEEDS ≥ 45 MPH TO 55 MPH
43	TRAFFIC CONTROL AND PROTECTION FOR SIDE ROADS, INTERSECTIONS AND DRIVEWAYS (TC-10)	701426-04	LANE CLOSURE, MULTILANE, INTERMITTENT OR MOVING OPERATIONS
44	TYPICAL APPLICATIONS: RAISED REFLECTIVE PAVEMENT MARKERS (SNOW-PLOW RESISTANT) (TC-11)	701427	LANE CLOSURE, MULTILANE, INTERMITTENT OR MOVING OPER., FOR SPEEDS ≤ 40 MPH
45	DISTRICT ONE TYPICAL PAVEMENT MARKINGS (TC-13)	701502-04	URBAN LANE CLOSURE, 2L, 2W, WITH BIDIRECTIONAL LEFT TURN LANE
46	TRAFFIC CONTROL AND PROTECTION OF TURN BAYS (TO REMAIN OPEN TO TRAFFIC) (TC-14)	701601-07	URBAN LANE CLOSURE, MULTILANE, 1W OR 2W WITH NONTRAVERSABLE MEDIAN
47	PAVEMENT MARKING LETTERS AND SYMBOLS FOR TRAFFIC STAGING (TC-16)	701602-05	URBAN LANE CLOSURE, MULTILANE, 2W WITH BIDIRECTIONAL LEFT TURN LANE
48	ARTERIAL ROAD INFORMATION SIGN (TC-22)	701606-07	URBAN LANE CLOSURE, MULTILANE, 2W WITH MOUNTABLE MEDIAN
49	STANDARD TRAFFIC SIGNAL DESIGN DETAILS (TS-05, SHEET 1 OF 6)	701701-07	URBAN LANE CLOSURE, MULTILANE INTERSECTION
50	DETECTOR LOOP INSTALLATION DETAIL FOR ROADWAY RESURFACING (TS-07)	701901-01	TRAFFIC CONTROL DEVICES

BEFORE STARTING ANY EXCAVATION, THE CONTRACTOR SHALL CALL "JULIE" AT (800) 892-0123 OR 811 FOR FIELD LOCATIONS OF BURIED ELECTRIC, TELEPHONE AND GAS FACILITIES. (48 HOUR NOTIFICATION REQUIRED)

THE CONTRACTOR WILL NOT BE ALLOWED TO SET UP A YARD OR FIELD OFFICE ON STATE (OR TOLLWAY) PROPERTY WITHOUT WRITTEN PERMISSION FROM THE DEPARTMENT (OR ISTHA)

WHEN ARTIFICIAL LIGHTING IS UTILIZED IN NIGHT OPERATIONS, THE CONTRACTOR SHALL EXERCISE THE UTMOST PRECAUTIONS IN PREVENTING ADVERSE VISIBILITY TO THE MOTORING PUBLIC AND ADJOINING RESIDENTIAL AREAS.

ANY PAVEMENT MARKINGS AND RAISED REFLECTIVE PAVEMENT MARKERS OBLITERATED BY MILLING AND RESURFACING OPERATIONS ON SIDE STREETS AND ENTRANCES SHALL BE REPLACED AND PAID FOR IN KIND.

BEFORE BEGINNING ANY WORK, THE CONTRACTOR SHALL RETAIN AND RECORD FOR FUTURE REFERENCE, ALL EXISTING PAVEMENT MARKING LINES (AND RAISED REFLECTIVE PAVEMENT MARKERS) IN ORDER THAT THESE LOCATIONS CAN BE RE-ESTABLISHED FOR STRIPING. EXACT LOCATIONS OF ALL PAVEMENT MARKINGS SHALL BE AS DIRECTED BY THE ENGINEER.

ALL PAVEMENT PATCHING LOCATIONS WILL BE DETERMINED IN THE FIELD BY THE ENGINEER.

THE CONTRACTOR SHALL CONTACT THE DISTRICT ONE TRAFFIC CONTROL SUPERVISOR AT (847) 705-4470 A MINIMUM OF 72 HOURS IN ADVANCE OF BEGINNING WORK.

THE ENGINEER SHALL CONTACT MS. DEBBIE HANLON, AREA TRAFFIC FIELD ENGINEER AT (847) 438-2300 MINIMUM OF TWO (2) WEEKS PRIOR TO PLACEMENT OF PERMANENT PAVEMENT MARKINGS.

DOUBLE LANE MARKERS ARE TO BE USED AS SHOWN ON THE DISTRICT ONE DETAIL "TYPICAL APPLICATIONS - RAISED REFLECTIVE PAVEMENT MARKERS (SNOW-PLOW RESISTANT)" SHOWN IN THE PLANS.

THE EXISTING ROADWAY TYPICAL SECTION IS ASSUMED TO HAVE A 3 INCH HOT-MIX ASPHALT OVERLAY ON TOP OF A TEN INCH CONCRETE BASE.

ALL PAVEMENT PATCHES SHOWN IN THE PLANS ARE TWO (2) INCH MILL AND RESURFACE ONLY. THE MINIMUM WIDTH FOR MILLING AND PATCHING SHALL BE TWO (2) FEET.

NO PATCHING OR RESURFACING IS TO BE DONE WITHIN FIFTY (50) FEET OF ANY RAILROAD CROSSING WITHOUT OBTAINING THE PROPER RAILROAD PROTECTIVE LIABILITY INSURANCE.

PAVEMENT MARKING TAPE, TYPE III SHALL BE USED FOR SHORT TERM PAVEMENT MARKINGS ON ALL FINAL SURFACES. THE COST OF THE PAVEMENT MARKING TAPE, TYPE III SHALL BE INCLUDED IN THE COST OF SHORT TERM PAVEMENT MARKING

THE COST OF TRAFFIC CONTROL AND PROTECTION FOR THE PROJECT SHALL BE INCLUDED IN THE COST OF THE ASSOCIATED ROAD WORK.

THE COST OF ANY PARTIAL OR FULL DEPTH PATCHING REQUIRED AFTER THE REMOVAL OF THE EXISTING 2 INCH HOT-MIX ASPHALT SURFACE SHALL BE PAID FOR IN ACCORDANCE WITH ARTICLE 109.04 OF THE STANDARD SPECIFICATIONS.

ANY DETECTOR LOOPS DAMAGED BY MILLING SHALL BE REPLACED IN KIND. IT SHALL BE THE RESPONSIBILITY OF THE CONTRACTOR TO QUANTIFY LOOP REPLACEMENTS NEEDED AND PROVIDE THE RESIDENT ENGINEER THIS INFORMATION PRIOR TO GRINDING OR REMOVAL.

WHEN MILLED PAVEMENT IS OPEN TO TRAFFIC, THE MAXIMUM GRADE DIFFERENTIAL BETWEEN PASSES OF THE MILLING MACHINE SHALL NOT EXCEED 1 1/2 INCHES (40MM) WHERE THE SPEED LIMIT IS 45 MPH (80 KM/H) OR LESS AND 1 INCH (25 MM) WHERE THE SPEED LIMIT IS GREATER THAN 45 MPH (80 KM/H). WITH WRITTEN APPROVAL FROM THE RESIDENT ENGINEER, A MAXIMUM GRADE DIFFERENTIAL OF 3 INCHES (75 MM) MAY BE ALLOWED IF THE EDGE OF THE MILLING IS SLOPED A MINIMUM OF 1:3 (V:H).

OVERNIGHT LANE CLOSURES SHALL NOT BE ALLOWED FOR REHABILITATION PROJECTS INVOLVING DAYTIME MILLING AND RESURFACING OPERATIONS AND CLASS D PATCHING UNLESS OTHER CONDITIONS WARRANT EXTENDED LANE CLOSURES AS DETERMINED AND APPROVED IN WRITING BY THE ENGINEER OR AS PROVIDED FOR IN THE CONTRACT SPECIFICATIONS. ANY MILLED PAVEMENT IS TO BE RESURFACED BY THE END OF EACH DAY AND OPEN TO TRAFFIC.

HOT-MIX ASPHALT MIXTURE REQUIREMENTS	
MIXTURE TYPE	AIR VOIDS (%)
HOT-MIX ASPHALT SURFACE COURSE, MIX "D", N70 (IL 9.5MM), 2"	4% @ 70 GYR

THE UNIT WEIGHT USED TO CALCULATE ALL HOT-MIX ASPHALT SURFACE MIXTURE QUANTITIES IS 112 LBS/SY/IN.

THE "AC TYPE" FOR POLYMERIZED HMA MIXES SHALL BE "SBS/SBR PG 70 -22" AND FOR NON-POLYMERIZED HMA THE "AC TYPE" SHALL BE "PG 64 -22" UNLESS MODIFIED BY DISTRICT ONE SPECIAL PROVISIONS. FOR "PERCENT OF RAP" SEE DISTRICT ONE SPECIAL PROVISIONS.

URBAN
100%
STATE

SUMMARY OF QUANTITIES				CONSTRUCTION TYPE CODE						SUMMARY OF QUANTITIES				CONSTRUCTION TYPE CODE					
CODE NO	ITEM	UNIT	TOTAL QUANTITIES							CODE NO	ITEM	UNIT	TOTAL QUANTITIES						
				0005															
40600200	BITUMINOUS MATERIALS (PRIME COAT)	TON	10	10															
40600300	AGGREGATE (PRIME COAT)	TON	51	51															
40600400	MIXTURE FOR CRACKS, JOINTS, AND FLANGWAYS	TON	76	76															
40600895	CONSTRUCTING TEST STRIP	EACH	1	1															
40600982	HOT-MIX ASPHALT SURFACE REMOVAL - BUTT JOINT	SO YD	764	764															
40603340	HOT-MIX ASPHALT SURFACE COURSE, MIX "D", N70	TON	2851	2851															
44000157	HOT-MIX ASPHALT SURFACE REMOVAL, 2"	SO YD	25454	25454															
67000400	ENGINEER'S FIELD OFFICE, TYPE A	CAL MO	6	6															
67100100	MOBILIZATION	L SUM	1	1															
70300100	SHORT TERM PAVEMENT MARKING	FOOT	4593	4593															
70301000	WORK ZONE PAVEMENT MARKING REMOVAL	SO FT	1531	1531															
* 78000100	THERMOPLASTIC PAVEMENT MARKING - LETTERS AND SYMBOLS	SO FT	597	597															
* 78000200	THERMOPLASTIC PAVEMENT MARKING - LINE 4"	FOOT	50519	50519															
* 78000400	THERMOPLASTIC PAVEMENT MARKING - LINE 6"	FOOT	1710	1710															
* 78000500	THERMOPLASTIC PAVEMENT MARKING - LINE 8"	FOOT	510	510															
* 78000600	THERMOPLASTIC PAVEMENT MARKING - LINE 12"	FOOT	553	553															
* 78000650	THERMOPLASTIC PAVEMENT MARKING - LINE 24"	FOOT	225	225															
* 78100100	RAISED REFLECTIVE PAVEMENT MARKER	EACH	983	983															
78300200	RAISED REFLECTIVE PAVEMENT MARKER REMOVAL	EACH	983	983															
* 88600600	DETECTOR LOOP REPLACEMENT	FOOT	807	807															
Z0030850	TEMPORARY INFORMATION SIGNING	SO FT	745	745															
Z0048665	RAILROAD PROTECTIVE LIABILITY INSURANCE	L SUM	1	1															

* SPECIALTY ITEM

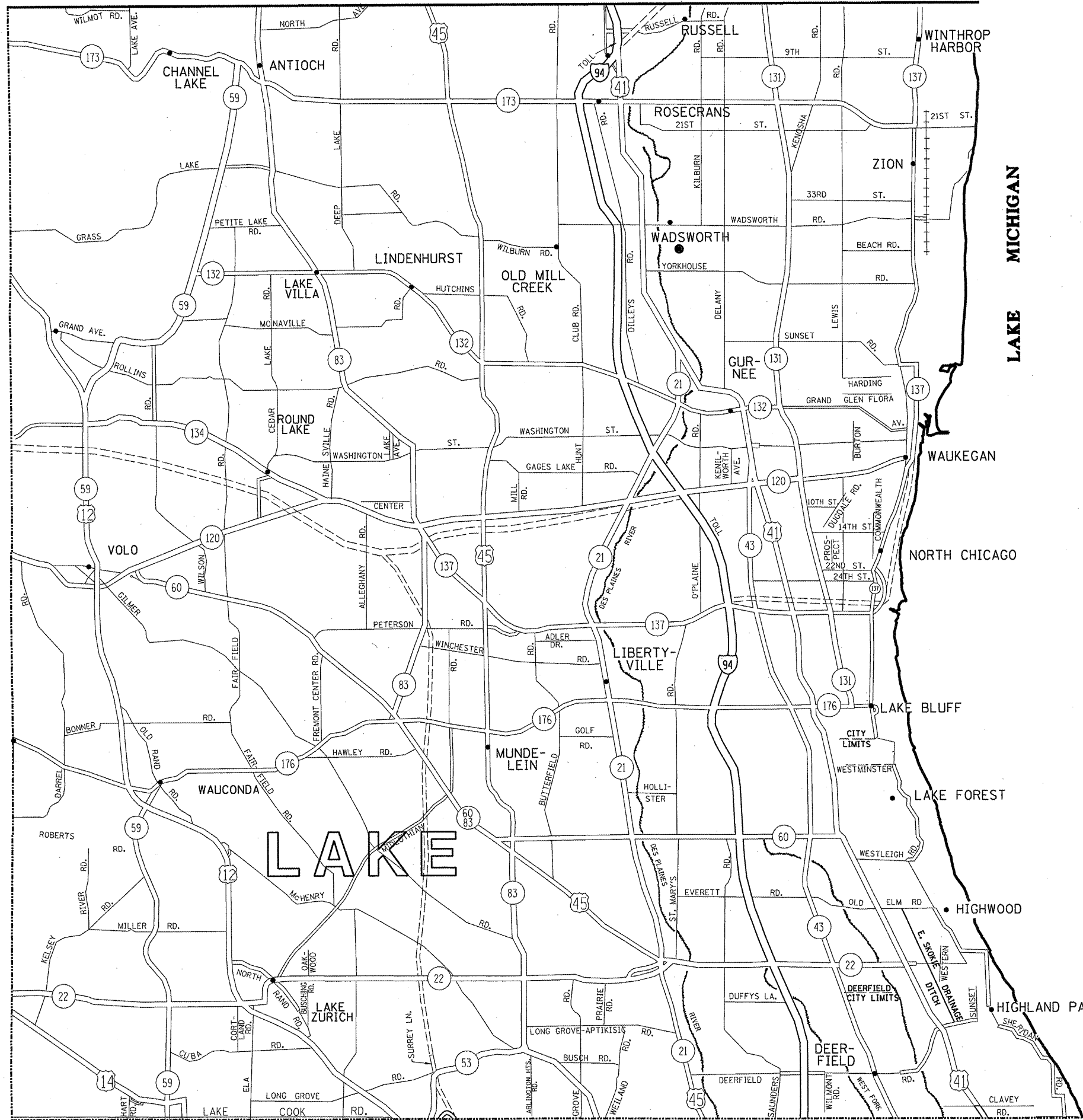

FILE NAME =
 c:\pwwork\p1\dot\velichkovv\ld0260110\d

USER NAME = VelichkovV
 design.dgn
 PLOT SCALE = 1000.0000 ' / IN.
 PLOT DATE = 4/13/2011

DESIGNED -	REVISED -
DRAWN -	REVISED -
CHECKED -	REVISED -
DATE -	REVISED -

**STATE OF ILLINOIS
 DEPARTMENT OF TRANSPORTATION**

GENERAL LOCATION MAP - LAKE COUNTY

SCALE: SHEET NO. OF SHEETS STA. TO STA.

F.A. RTE.	SECTION	COUNTY	TOTAL SHEETS	SHEET NO.
VAR.	2011-007-R5	LAKE	50	4
CONTRACT NO. 60N95				
FED. ROAD DIST. NO. 1 ILLINOIS FED. AID PROJECT				

SUMMARY - EAST LAKE COUNTY ROUTES	HMA 2" MILL & RESURFACE (SY)
FRONTAGE ROAD (EAST SIDE OF I-94 FROM RUSSELL RD TO EDWARDS RD)	1867
IL 131 (SUNSET AVE TO WADSWORTH RD)	1402
IL 131 (IL 176 TO RR CROSSING)	1124
IL 132 (FROM TOLLWAY BRIDGE TO TOLLWAY RAMPS)	1954
IL 132 (INTERSECTION OF HUNT CLUB RD)	405
IL 132 (O'PLAINE RD TO GREENLEAF AVE)	1176
IL 137 (BUTTERFIELD RD TO IL 21)	5238
IL 137 (1,000 FT OF IL 21 TO IL 21)	623
IL 137 (SHERIDAN RD TO IL 137)	363
IL 21 (IL 60 TO IL 22 APTAKISIC RD. (NEW LIMIT))	5584
IL 60 (IL 60/83 TO IL 21)	240
RUSSELL ROAD (EDWARDS RD TO OLD SKOKIE RD)	814
US 41 (IL 120 TO IL 22)	4328
US 45: OLDE HALF DAY RD. (IL 21: MILWAUKEE AVE. TO IL 22: HALF DAY RD.)	336
EAST LAKE COUNTY TOTALS =	25454 SY

ROUTE: US 41 (IL 120 to IL 22)

CROSSSTREETS		DIRECTION (EB/WB) (NB/SB)	LANE NO. (1, 2, 3)	PAVEMENT PATCH WIDTH	PAVEMENT PATCH LENGTH	REPAIR AREA (SQ FT)	REPAIR AREA (SQ YD)
FROM	TO						
		SB	2	12	2	24	3
		SB	2	12	2	24	3
		SB	2	12	2	24	3
		SB	2	12	2	24	3
		SB	2	12	2	24	3
		SB	2	12	2	24	3
		SB	2	12	2	24	3
		SB	2	12	2	24	3
		SB	2	12	2	24	3
		SB	2	12	2	24	3
		SB	2	12	2	24	3
		SB	2	12	2	24	3
		SB	2	12	2	24	3
		SB	2	12	2	24	3
		SB	2	12	2	24	3
		SB	2	2	50	100	11
		SB	2	2	50	100	11
		SB	2	2	50	100	11
		SB	2	2	50	100	11
		SB	2	2	50	100	11
		SB	2	2	50	100	11
		SB	2	2	50	100	11
		SB	2	2	50	100	11
		SB	2	2	50	100	11
		SB	2	2	50	100	11
		SB	2	2	50	100	11
		SB	2	2	50	100	11
		SB	2	2	50	100	11
		SB	2	2	50	100	11
		SB	2	2	50	100	11
		SB	2	2	50	100	11
		SB	2	2	50	100	11
		SB	2	2	50	100	11
		SB	2	2	50	100	11
		SB	2	2	50	100	11
		SB	2	2	50	100	11
		SB	2	2	50	100	11
		SB	2	2	50	100	11
		SB	2	2	50	100	11
		SB	2	2	50	100	11
		SB	2	2	50	100	11
		SB	2	2	50	100	11
		SB	2	2	50	100	11
		SB	2	2	50	100	11
		SB	2	2	50	100	11
		SB	2	2	50	100	11
		SB	2	2	50	100	11
		SB	2	2	50	100	11
		SB	2	2	50	100	11
		SB	2	2	50	100	11
		SB	2	2	50	100	11
		SB	2	2	50	100	11
		SB	2	2	50	100	11
		SB	2	2	50	100	11
		SB	2	2	50	100	11
		SB	2	2	50	100	11
		SB	2	2	50	100	11
		SB	2	2	50	100	11
		SB	2	2	50	100	11
		SB	2	2	50	100	11
		SB	2	2	50	100	11
		SB	2	2	50	100	11
		SB	2	2	50	100	11
		SB	2	2	50	100	11
		SB	2	2	50	100	11
		SB	2	2	50	100	11

ROUTE: US 41 (IL 120 to IL 22)

CROSSSTREETS		DIRECTION (EB/WB) (NB/SB)	LANE NO. (1, 2, 3)	PAVEMENT PATCH WIDTH	PAVEMENT PATCH LENGTH	REPAIR AREA (SQ FT)	REPAIR AREA (SQ YD)
FROM	TO						
		SB	2	2	50	100	11
		NB	1	12	2	24	3
		NB	1	12	2	24	3
		NB	1	12	2	24	3
		NB	1	12	2	24	3
		NB	1	12	2	24	3
		NB	1	12	2	24	3
		NB	1	12	2	24	3
		NB	1	12	2	24	3
		NB	1	12	2	24	3
		NB	1	12	2	24	3
		NB	1	12	2	24	3
		NB	1	12	2	24	3
		NB	1	12	2	24	3
		NB	1	12	2	24	3
		NB	1	12	2	24	3
		NB	1	12	2	24	3
		NB	1	12	2	24	3
		NB	1	12	2	24	3
		NB	1	12	2	24	3
		NB	1	12	2	24	3
		NB	1	12	2	24	3
		NB	1	12	2	24	3
		NB	1	12	2	24	3
		NB	1	12	2	24	3
		NB	1	12	2	24	3
		NB	1	12	2	24	3
		NB	1	12	2	24	3
		NB	1	12	2	24	3
		NB	1	12	2	24	3
		NB	1	12	2	24	3
		NB	1	12	2	24	3
		NB	1	12	2	24	3
		NB	1	12	2	24	3
		NB	1	12	2	24	3
		NB	1	12	2	24	3
		NB	1	12	2	24	3
		NB	1	12	2	24	3
		NB	1	12	2	24	3
		NB	1	12	2	24	3
		NB	1	12	2	24	3
		NB	1	12	2	24	3
		NB	1	12	2	24	3
		NB	1	12	2	24	3
		NB	1	12	2	24	3
		NB	1	12	2	24	3
		NB	1	12	2	24	3
		NB	1	12	2	24	3
		NB	1	12	2	24	3
		NB	1	12	2	24	3
		NB	1	12	2	24	3
		NB	1	12	2	24	3
		NB	1	12	2	24	3
		NB	1	12	2	24	3
		NB	1	12	2	24	3
		NB	1	12	2	24	3
		NB	1	12	2	24	3
		NB	1	12	2	24	3
		NB	1	12	2	24	3
		NB	1	12	2	24	3
		NB	1	12	2	24	3
		NB	1	12	2	24	3
		NB	1	12	2	24	3
		NB	1	12	2	24	3
		NB	1	12	2	24	3
		NB	1	12	2	24	3
		NB	1	12	2	24	3
		NB	1	12	2	24	3
		NB	1	12	2	24	3
		NB	1	12	2	24	3
		NB	1	12	2	24	3
		NB	1	12	2	24	3
		NB	1	12	2	24	3

CONTINUED ON NEXT SHEET

ROUTE: US 41 (IL 120 to IL 22)

CROSS STREETS		DIRECTION (EB/WB) (NB/SB)	LANE NO. (1, 2, 3)	PAVEMENT PATCH WIDTH	PAVEMENT PATCH LENGTH	REPAIR AREA (SQ FT)	REPAIR AREA (SQ YD)
FROM	TO						
		NB	1	12	2	24	3
		NB	1	12	2	24	3
		NB	1	12	2	24	3
		NB	1	12	2	24	3
		NB	1	12	2	24	3
		NB	1	12	2	24	3
		NB	1	12	2	24	3
		NB	1	12	2	24	3
		NB	1	12	2	24	3
		NB	1	12	2	24	3
		NB	1	12	2	24	3
		NB	1	12	2	24	3
		NB	1	12	2	24	3
		NB	1	12	2	24	3
		NB	1	12	2	24	3
		NB	1	12	2	24	3
		NB	1	12	2	24	3
		NB	1	12	2	24	3
		NB	1	12	2	24	3
		NB	1	12	2	24	3
		NB	1	12	2	24	3
		NB	1	12	2	24	3
		NB	1	12	2	24	3
		NB	1	12	2	24	3
		NB	1	12	2	24	3
		NB	1	12	2	24	3
		NB	1	12	2	24	3
		NB	1	12	2	24	3
		NB	1	12	2	24	3
		NB	1	12	2	24	3
		NB	1	12	2	24	3
		NB	1	12	2	24	3
		NB	1	12	2	24	3
		NB	1	12	2	24	3
		NB	1	12	2	24	3
		NB	1	12	2	24	3
		NB	1	12	2	24	3
		NB	1	12	2	24	3
		NB	1	12	2	24	3
		NB	1	12	2	24	3
		NB	1	12	2	24	3
		NB	1	12	2	24	3
		NB	1	2	50	100	11
		NB	1	2	50	100	11
		NB	1	2	50	100	11
		NB	1	2	50	100	11
		NB	1	2	50	100	11
		NB	1	2	50	100	11
		NB	1	2	50	100	11
		NB	1	2	50	100	11
		NB	1	2	50	100	11
		NB	1	2	50	100	11
		NB	1	2	50	100	11
		NB	1	2	50	100	11
		NB	1	2	50	100	11
		NB	1	2	50	100	11
		NB	1	2	50	100	11
		NB	1	2	50	100	11
		NB	1	2	50	100	11
		NB	1	2	50	100	11
		NB	1	2	50	100	11
		NB	1	2	50	100	11
		NB	1	2	50	100	11
		NB	1	2	50	100	11
		NB	1	2	50	100	11

ROUTE: US 41 (IL 120 to IL 22)

CROSS STREETS		DIRECTION (EB/WB) (NB/SB)	LANE NO. (1, 2, 3)	PAVEMENT PATCH WIDTH	PAVEMENT PATCH LENGTH	REPAIR AREA (SQ FT)	REPAIR AREA (SQ YD)
FROM	TO						
		NB	1	2	50	100	11
		NB	1	2	50	100	11
		NB	1	2	50	100	11
		NB	1	2	50	100	11
		NB	1	2	50	100	11
		NB	1	2	50	100	11
		NB	2	12	2	24	3
		NB	2	12	2	24	3
		NB	2	12	2	24	3
		NB	2	12	2	24	3
		NB	2	12	2	24	3
		NB	2	12	2	24	3
		NB	2	12	2	24	3
		NB	2	12	2	24	3
		NB	2	12	2	24	3
		NB	2	12	2	24	3
		NB	2	12	2	24	3
		NB	2	12	2	24	3
		NB	2	12	2	24	3
		NB	2	12	2	24	3
		NB	2	12	2	24	3
		NB	2	12	2	24	3
		NB	2	12	2	24	3
		NB	2	12	2	24	3
		NB	2	12	2	24	3
		NB	2	12	2	24	3
		NB	2	12	2	24	3
		NB	2	12	2	24	3
		NB	2	12	2	24	3
		NB	2	12	2	24	3
		NB	2	12	2	24	3
		NB	2	12	2	24	3
		NB	2	12	2	24	3
		NB	2	12	2	24	3
		NB	2	12	2	24	3
		NB	2	12	2	24	3
		NB	2	12	2	24	3
		NB	2	12	2	24	3
		NB	2	12	2	24	3
		NB	2	12	2	24	3
		NB	2	12	2	24	3
		NB	2	12	2	24	3
		NB	2	12	2	24	3
		NB	2	12	2	24	3
		NB	2	12	2	24	3
		NB	2	12	2	24	3
		NB	2	12	2	24	3
		NB	2	12	2	24	3
		NB	2	12	2	24	3
		NB	2	12	2	24	3
		NB	2	12	2	24	3
		NB	2	12	2	24	3
		NB	2	12	2	24	3
		NB	2	12	2	24	3
		NB	2	12	2	24	3
		NB	2	12	2	24	3
		NB	2	12	2	24	3
		NB	2	12	2	24	3
		NB	2	12	2	24	3
		NB	2	12	2	24	3
		NB	2	12	2	24	3
		NB	2	12	2	24	3
		NB	2	12	2	24	3
		NB	2	12	2	24	3
		NB	2	12	2	24	3
		NB	2	12	2	24	3
		NB	2	12	2	24	3
		NB	2	12	2	24	3
		NB	2	12	2	24	3
		NB	2	12	2	24	3

CONTINUED ON NEXT SHEET

ROUTE: US 41 (IL 120 to IL 22)

ROUTE: US 41 (IL 120 to IL 22)

Table with 8 columns: CROSSSTREETS (FROM, TO), DIRECTION (EB/WB), LANE NO., PAVEMENT PATCH WIDTH, PAVEMENT PATCH LENGTH, REPAIR AREA (SO FT), REPAIR AREA (SO YD). Contains 30 rows of data.

Table with 8 columns: CROSSSTREETS (FROM, TO), DIRECTION (EB/WB), LANE NO., PAVEMENT PATCH WIDTH, PAVEMENT PATCH LENGTH, REPAIR AREA (SO FT), REPAIR AREA (SO YD). Contains 30 rows of data.

CONTINUED ON NEXT SHEET

ROUTE: US 45: Olde Half Day Rd. (IL 21: Milwaukee Ave. to IL 22: Half Day Rd.)

CROSS STREETS		DIRECTION (EB/WB) (NB/SB)	LANE NO. (1, 2, 3)	PAVEMENT PATCH WIDTH	PAVEMENT PATCH LENGTH	REPAIR AREA (SQ FT)	REPAIR AREA (SQ YD)		
FROM	TO								
Rte 21	Rte 22	EB	1	12	6	72	8		
		EB	1	12	10	120	13		
		EB	1	12	10	120	13		
		EB	1	12	5	60	7		
		EB	1	12	5	60	7		
		EB	1	12	2	24	3		
		EB	1	12	2	24	3		
		EB	1	12	2	24	3		
		EB	1	12	2	24	3		
		EB	1	12	2	24	3		
		EB	1	12	2	24	3		
		EB	1	12	2	24	3		
		EB	1	12	2	24	3		
		EB	1	12	2	24	3		
		EB	1	12	2	24	3		
		EB	1	12	2	24	3		
		EB	1	12	2	24	3		
		EB	1	12	2	24	3		
		Rte 21	Rte 22	WB	1	12	10	120	13
				WB	1	12	10	120	13
WB	1			12	10	120	13		
WB	1			12	10	120	13		
WB	1			12	10	120	13		
WB	1			12	10	120	13		
WB	1			12	10	120	13		
WB	1			12	10	120	13		
WB	1			6	25	150	17		
WB	1			6	25	150	17		
WB	1			2	50	100	11		
WB	1			2	50	100	11		
WB	1			2	50	100	11		
WB	1			2	50	100	11		
WB	1			6	25	150	17		
WB	1			6	25	150	17		
WB	1			12	2	24	3		
WB	1			12	2	24	3		
WB	1			12	2	24	3		
WB	1			12	2	24	3		
WB	1	12	2	24	3				
WB	1	12	2	24	3				

TOTALS: 510 FT 336 SY

FILE NAME = c:\pwwork\pwwork\velichkovv\d0260110\d0260110.dgn	USER NAME = VelichkovV	DESIGNED -	REVISED -	STATE OF ILLINOIS DEPARTMENT OF TRANSPORTATION	PATCHING SCHEDULE US 45: OLDE HALF DAY RD				F.A. RTE.	SECTION	COUNTY	TOTAL SHEETS	SHEET NO.
		DRAWN -	REVISED -		SCALE:	SHEET NO.	OF	SHEETS	STA.	TO STA.	LAKE	50	41
		CHECKED -	REVISED -		CONTRACT NO. 60N95								
		DATE -	REVISED -		FED. ROAD DIST. NO. 1 ILLINOIS FED. AID PROJECT								

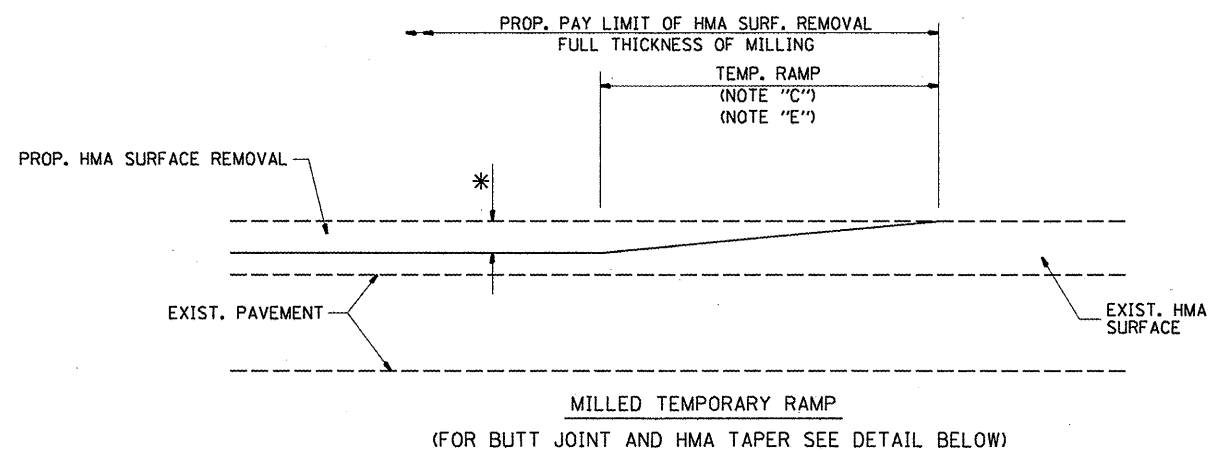

OPTION 1

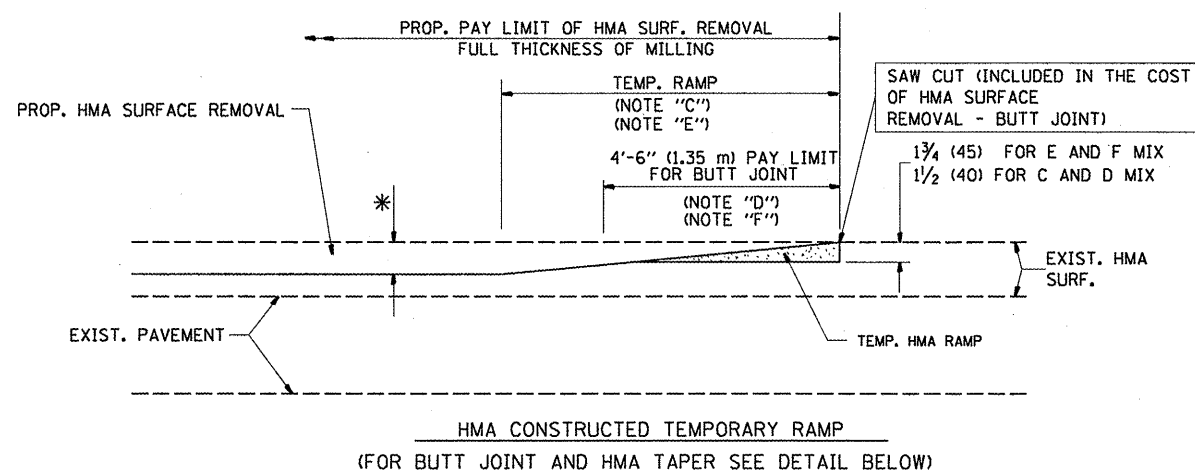

OPTION 2

TYPICAL TEMPORARY RAMP

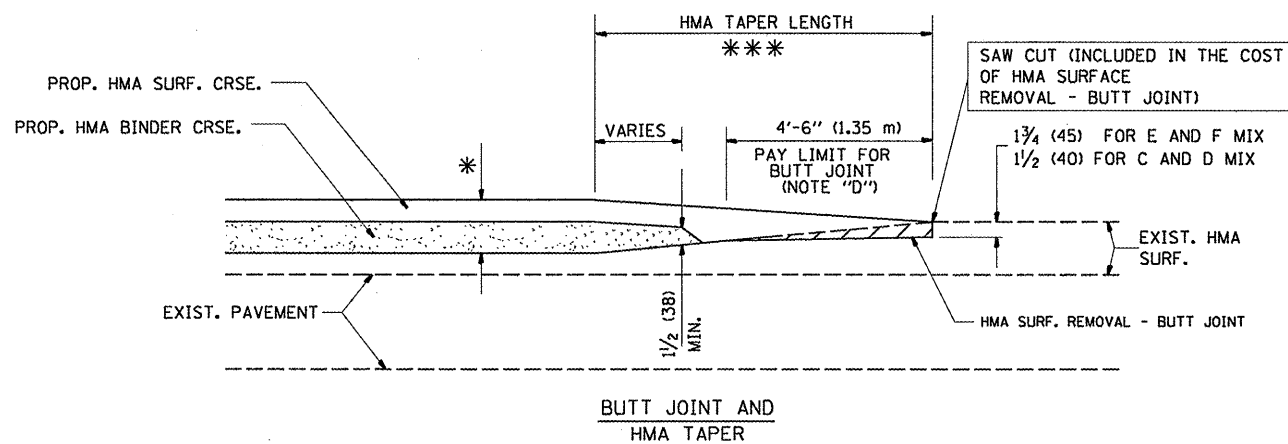

TYPICAL BUTT JOINT AND HMA TAPER FOR MILLING AND RESURFACING

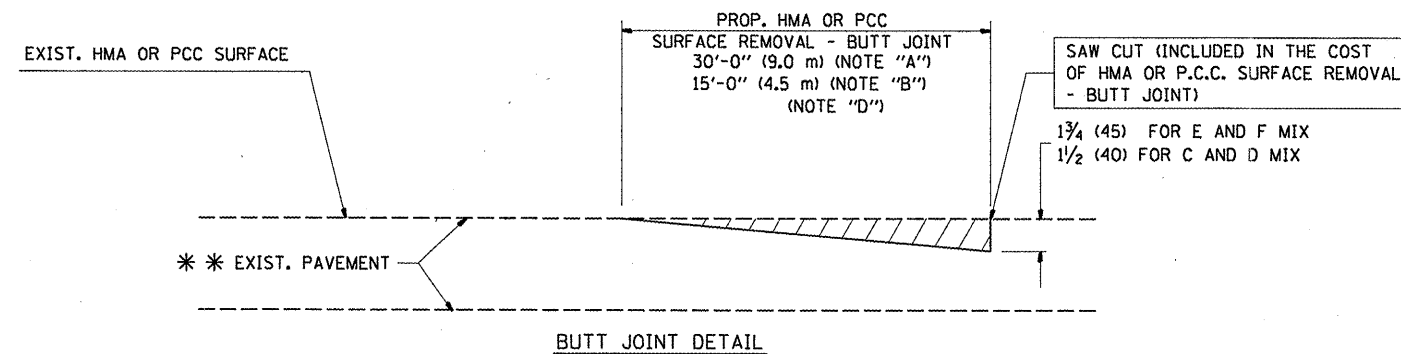

BUTT JOINT DETAIL

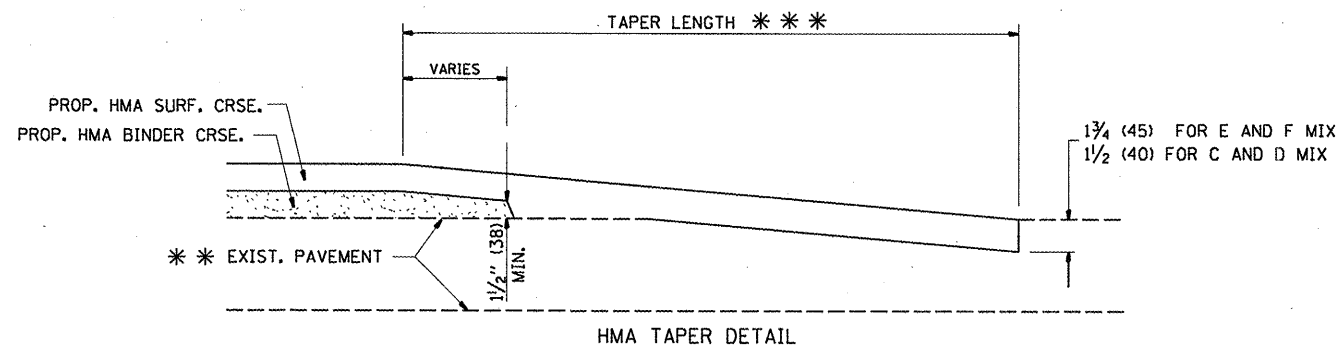

HMA TAPER DETAIL

TYPICAL BUTT JOINT AND HMA TAPER FOR RESURFACING ONLY

*** PC CONCRETE, HMA OR HMA RESURFACED PAVEMENT.

NOTES

- A: MAINLINE ROADWAYS AND MAJOR SIDE ROADS.
 - B: MINOR SIDE ROADS.
 - C: THE TEMP. RAMP SHALL BE CONSTRUCTED IMMEDIATELY UPON REMOVAL OF THE EXISTING HMA SURFACE.
 - D: THE BUTT JOINT SHALL BE CONSTRUCTED IMMEDIATELY PRIOR TO PLACING THE PROPOSED HMA COURSES.
 - E: TAPER THE TEMP. RAMP AT A RATE OF 3'-0" (900 mm) PER 1 INCH (25 mm) OF MILLING THICKNESS.
 - F: INSTALLATION AND REMOVAL OF THE 4'-6" (1.35 m) TEMP. RAMP IS INCLUDED IN COST OF HMA SURFACE REMOVAL - BUTT JOINT
 - G: SEE ARTICLE 406.08 AND 406.14 OF THE STANDARD SPECIFICATIONS FOR "HMA AND/OR PCC SURFACE REMOVAL, BUTT JOINT".
- * SEE TYPICAL SECTIONS FOR MILLING THICKNESS.
- *** 20'-0" (6.1 m) PER 1 (25) RESURFACING (NOTE "A")
 10'-0" (3.0 m) PER 1 (25) RESURFACING (NOTE "B")

BASIS OF PAYMENT:

THE BUTT JOINT WILL BE PAID FOR AT THE CONTRACT UNIT PRICE PER SQUARE YARD (SQUARE METER) FOR "HOT-MIX ASPHALT SURFACE REMOVAL - BUTT JOINT" OR FOR "PORTLAND CEMENT CONCRETE SURFACE REMOVAL - BUTT JOINT".

ALL DIMENSIONS ARE IN INCHES (MILLIMETERS) UNLESS OTHERWISE SHOWN.

FILE NAME =	USER NAME = VelichkovV	DESIGNED - M. DE YONG	REVISED - R. SHAH 10-25-94
ct:\pw\work\pww\dos\velichkovv\d026010\d026010std.dgn		DRAWN -	REVISED - A. ABBAS 03-21-97
PLOT SCALE = 100.0000' / IN.		CHECKED -	REVISED - M. GOMEZ 04-06-01
PLOT DATE = 4/13/2011		DATE - 06-13-90	REVISED - R. BORO 01-01-07

**STATE OF ILLINOIS
DEPARTMENT OF TRANSPORTATION**

**BUTT JOINT AND
HMA TAPER DETAILS**

SCALE: NONE SHEET NO. 1 OF 1 SHEETS STA. TO STA.

F.A. RTE. VAR.	SECTION 2011-007-RS	COUNTY LAKE	TOTAL SHEETS 50	SHEET NO. 42
BD400-05 BD32		CONTRACT NO. 60N95		
FED. ROAD DIST. NO. 1 ILLINOIS FED. AID PROJECT				

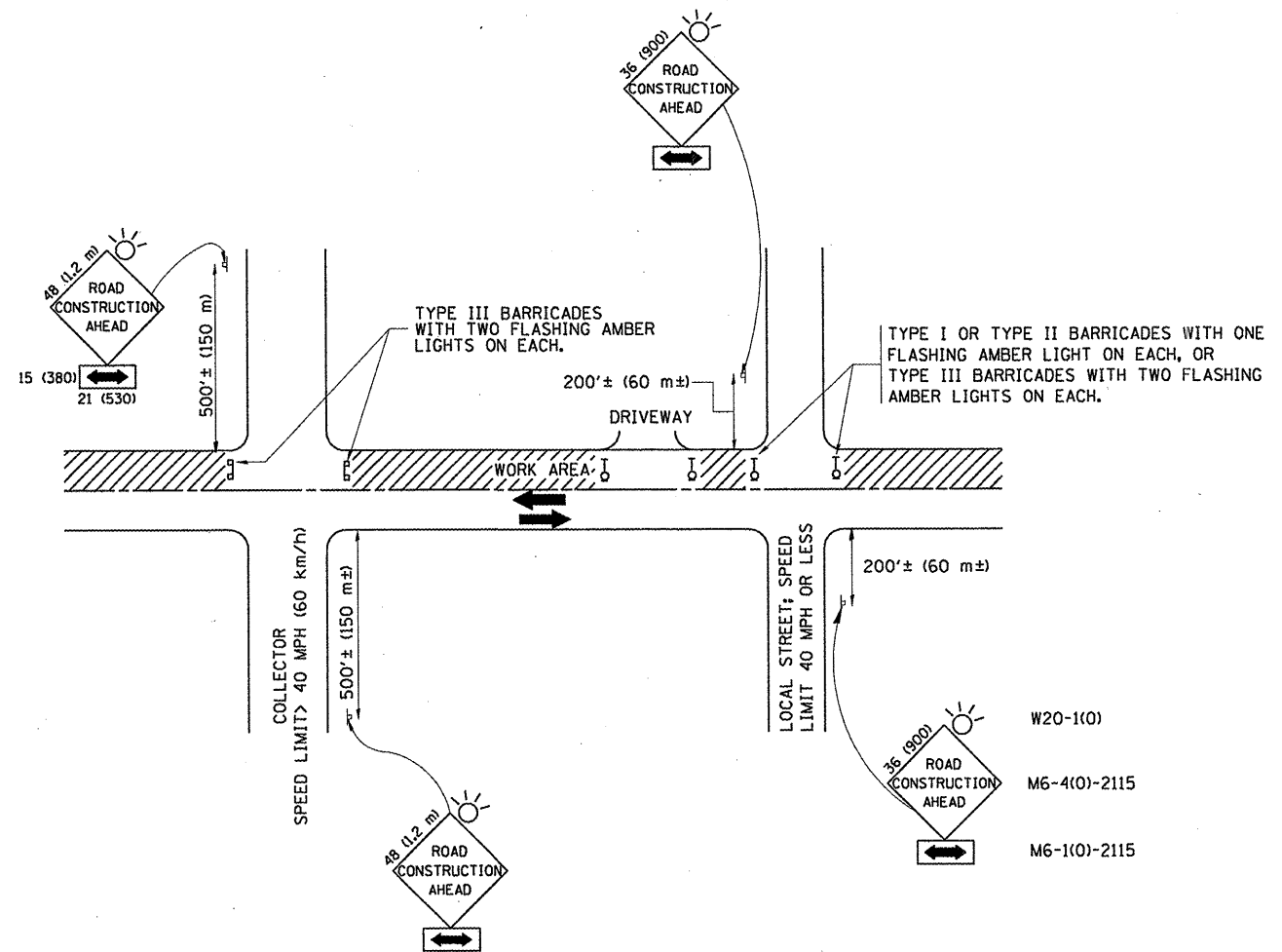

TRAFFIC CONTROL AND PROTECTION FOR SIDE ROADS, INTERSECTIONS, AND DRIVEWAYS

NOTES:

A. FOR NO LANE RESTRICTION ON THE SIDE ROAD OR DRIVEWAYS

1. SIDE ROAD WITH A SPEED LIMIT OF 40 MPH (60 km/h) OR LESS AS SHOWN ON THE DRAWING AND AS DIRECTED BY THE ENGINEER:
 - a) ONE ROAD CONSTRUCTION AHEAD SIGN 36 x 36 (900x900) WITH A FLASHER AND FLAG MOUNTED ON IT APPROXIMATELY 200' (60 m) IN ADVANCE OF THE MAIN ROUTE.
 - b) THE CLOSED PORTION OF THE MAIN ROUTE SHALL BE PROTECTED BY BLOCKING WITH TYPE I, TYPE II OR TYPE III BARRICADES, 1/3 OF THE CROSS SECTION OF THE CLOSED PORTION.
2. SIDE ROAD WITH A SPEED LIMIT GREATER THAN 40 MPH (60 km/h) AS SHOWN ON THE DRAWING AND AS DIRECTED BY THE ENGINEER:
 - a) ONE ROAD CONSTRUCTION AHEAD SIGN 48 x 48 (1.2 m x 1.2 m) WITH A FLASHER MOUNTED ON IT APPROXIMATELY 500' (150 m) IN ADVANCE OF THE MAIN ROUTE.
 - b) THE CLOSED PORTION OF THE MAIN ROUTE SHALL BE PROTECTED BY BLOCKING WITH TYPE III BARRICADES, 1/2 OF THE CROSS SECTION OF THE CLOSED PORTION.
3. WHEN THE SIDE ROAD LIES BETWEEN THE BEGINNING OF THE MAINLINE SIGNING AND THE WORK ZONE, A SINGLE HEADED ARROW (M6-1) SHALL BE USED IN LIEU OF THE DOUBLE HEADED ARROW (M6-4).

B. FOR A LANE CLOSURE ON A SIDE ROAD OR DRIVEWAY:

- USE APPLICABLE PORTIONS OF THE TYPICAL APPLICATION OF TRAFFIC CONTROL DEVICES (STD. 701501, STD. 701606 OR THE APPROPRIATE STANDARD). THE SPACING OF SIGNS AND BARRICADES SHALL BE ADJUSTED FOR FIELD CONDITIONS AS DIRECTED BY THE ENGINEER. THE DIRECTIONAL ARROW SHALL BE COVERED OR REMOVED WHEN NO LONGER CONSISTENT WITH THE SIDE ROAD LANE CLOSURE.
- C. ADVANCE WARNING SIGNS ARE TO BE OMITTED ON DRIVEWAY UNLESS OTHERWISE NOTED.
- D. THE TRAFFIC CONTROL AND PROTECTION FOR SIDE ROADS, INTERSECTIONS, AND DRIVEWAYS SHALL BE INCIDENTAL TO THE COST OF SPECIFIED TRAFFIC CONTROL STANDARDS OR ITEMS.

All dimensions are in millimeters (inches) unless otherwise shown.

FILE NAME =	USER NAME = VelichkovVV	DESIGNED - LHA	REVISED - J. OBERLE 10-18-95
ct:\pwwork\pwwork\velichkovvv\d0268110\d	stStd.dgn	DRAWN -	REVISED - A. HOUSEH 03-06-96
	PLOT SCALE = 100.0000 * / IN.	CHECKED -	REVISED - A. HOUSEH 10-15-96
	PLOT DATE = 4/13/2011	DATE - 06-89	REVISED - T. RAMMACHER 01-06-00

STATE OF ILLINOIS
DEPARTMENT OF TRANSPORTATION

TRAFFIC CONTROL AND PROTECTION FOR
SIDE ROADS, INTERSECTIONS, AND DRIVEWAYS

SCALE: NONE SHEET NO. 1 OF 1 SHEETS STA. TO STA.

F.A. RTE.	SECTION	COUNTY	TOTAL SHEETS	SHEET NO.
VAR.	2011-007-RS	LAKE	50	43
TC-10		CONTRACT NO. 60N95		
FED. ROAD DIST. NO. 1 ILLINOIS FED. AID PROJECT				

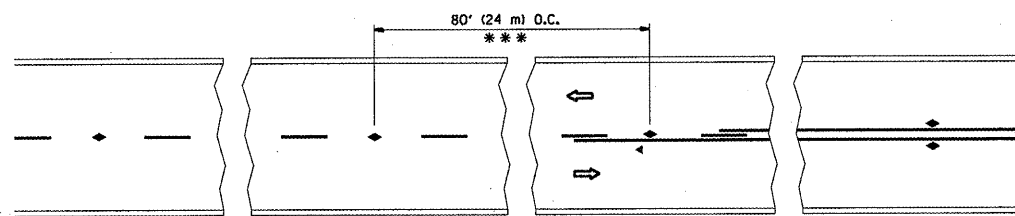

*** REDUCE TO 40' (12 m) O.C. ON CURVES WITH POSTED OR ADVISORY SPEED 45 M.P.H. (70 km/h) OR LESS.

TWO-LANE/TWO-WAY

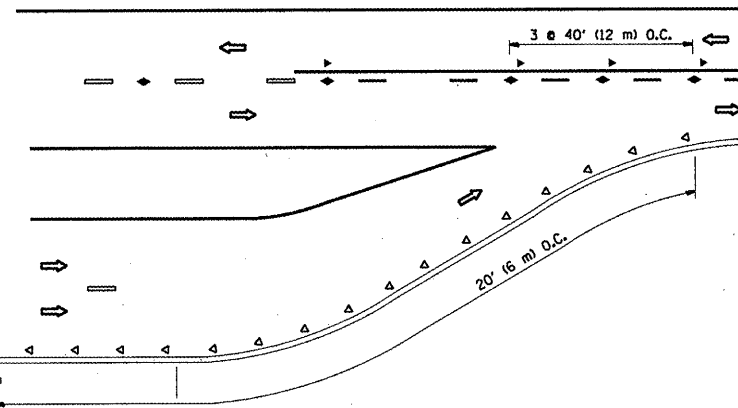

LANE REDUCTION TRANSITION

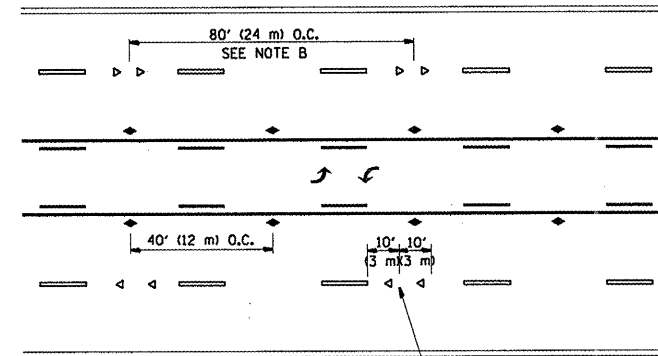

TWO-WAY LEFT TURN

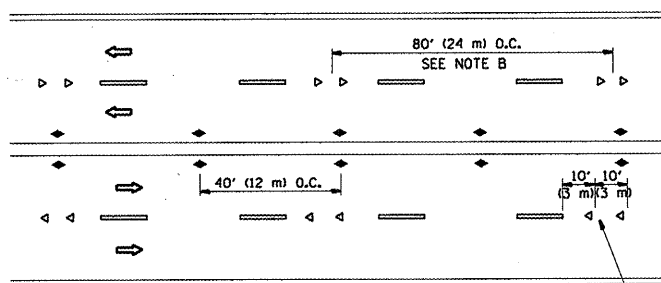

MULTI-LANE/UNDIVIDED

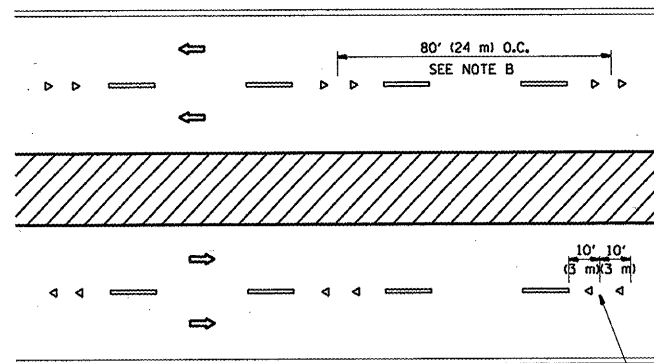

MULTI-LANE/DIVIDED

GENERAL NOTES

1. MARKERS USED WITH DASHED LINES SHALL BE CENTERED IN THE GAP BETWEEN SEGMENTS.
2. MARKERS USED ADJACENT TO SOLID LINES SHALL BE OFFSET 2 TO 3 (50 TO 75) TOWARD TRAFFIC AS SHOWN.
3. MARKERS THROUGH TANGENTS LESS THAN 500' (150 m) IN LENGTH BETWEEN CURVES SHALL BE INSTALLED AT THE LESSER OF THE TWO CURVE SPACINGS.

SYMBOLS

- YELLOW STRIPE
- WHITE STRIPE
- ◀ ONE-WAY AMBER MARKER
- ◁ ONE-WAY CRYSTAL MARKER (W/O)
- ◆ TWO-WAY AMBER MARKER

LANE MARKER NOTES

- A. USE DOUBLE LANE LINE MARKERS SPACED AS SHOWN.
- B. REDUCE TO 40' (12 m) O.C. ON CURVES WHERE ADVISORY SPEEDS ARE 10 M.P.H (20 km/h) LOWER THAN POSTED SPEEDS.

DESIGN NOTES

1. DOUBLE LANE LINE MARKERS SHALL BE USED UNLESS SPECIFIED OTHERWISE.
2. EXCEPT AS SHOWN ON THE LANE REDUCTION TRANSITION AND FREEWAY EXIT RAMP DETAIL, MARKERS ARE NOT TO BE SPECIFIED ON RIGHT EDGE LINES.
3. THE EXACT MARKER LIMITS, SPACING, AND COLOR SHALL BE INCLUDED IN THE PLANS WHEN STANDARD SPECIFICATIONS ARE NOT BEING USED.
4. MARKERS SHOULD NOT BE USED ALONGSIDE CURBS EXCEPT FOR EXTREMELY SHORT SECTIONS OF CURBS WHERE NOT MORE THAN TWO MARKERS WOULD BE INVOLVED.

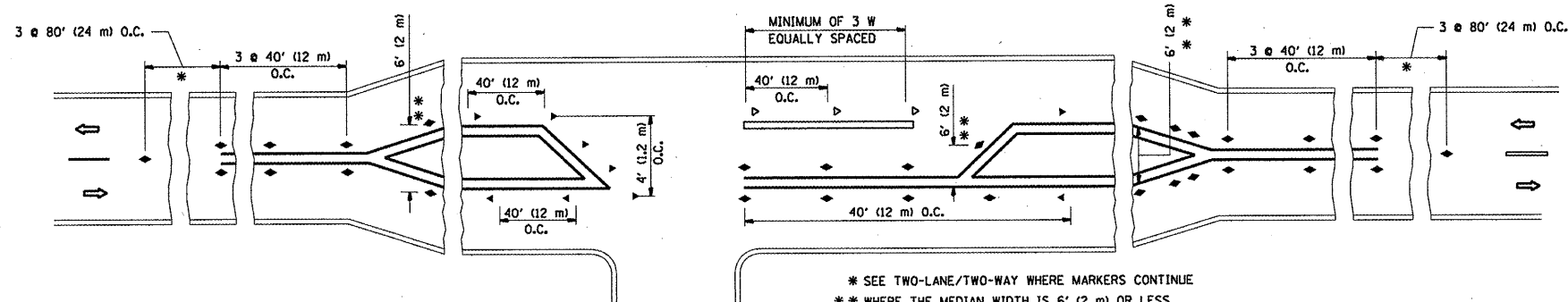

LEFT TURN

* SEE TWO-LANE/TWO-WAY WHERE MARKERS CONTINUE
 ** WHERE THE MEDIAN WIDTH IS 6' (2 m) OR LESS USE TWO-WAY MARKERS.

All dimensions are in inches (millimeters) unless otherwise shown.

FILE NAME =	USER NAME = VelschkovVV	DESIGNED -	REVISED - T. RAMMACHER 09-19-94	STATE OF ILLINOIS DEPARTMENT OF TRANSPORTATION	TYPICAL APPLICATIONS		F.A. -	SECTION	COUNTY	TOTAL	SHEET
ca:\pwwork\pwwork\velschkovv\d0260110\d0260110.dgn	etStd.dgn	DRAWN -	REVISED - T. RAMMACHER 03-12-99		RAISED REFLECTIVE PAVEMENT MARKERS (SNOW-PLOW RESISTANT)		VAR.	2011-007-RS	LAKE	50	44
	PLOT SCALE = 1/8" = 1'-0"	CHECKED -	REVISED - T. RAMMACHER 01-06-00		SCALE: NONE	SHEET NO. 1 OF 1 SHEETS	STA.	TC-11		CONTRACT NO. 60N95	
	PLOT DATE = 4/13/2011	DATE -	REVISED - C. JUCIUS 09-09-09					FED. ROAD DIST. NO. 1 ILLINOIS FED. AID PROJECT			

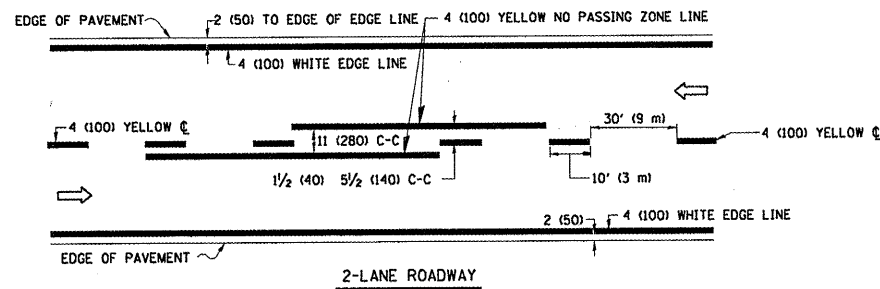

2-LANE ROADWAY

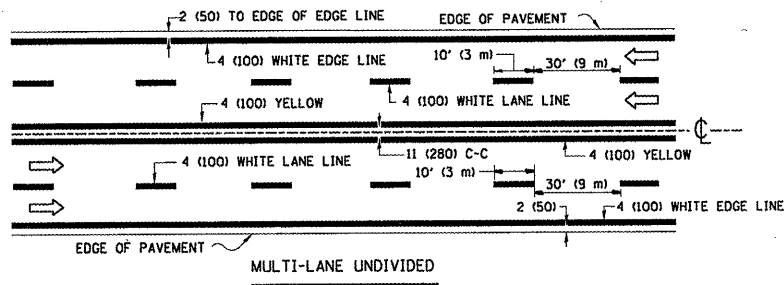

MULTI-LANE UNDIVIDED

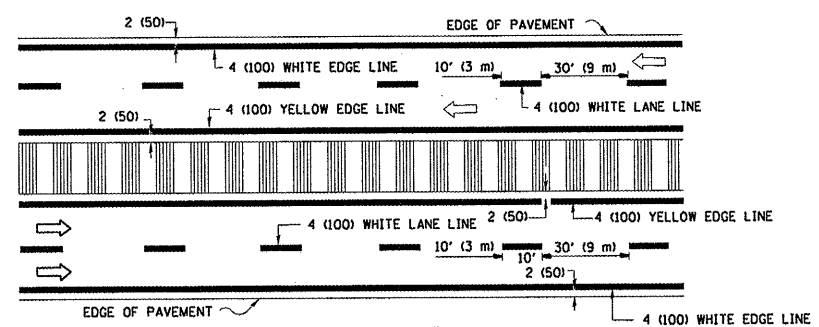

MULTI-LANE DIVIDED WITH MOUNTABLE MEDIAN

NOTE: MEDIANS WITH BARRIER CURB DO NOT REQUIRE AN EDGE LINE

TYPICAL LANE AND EDGE LINE MARKING

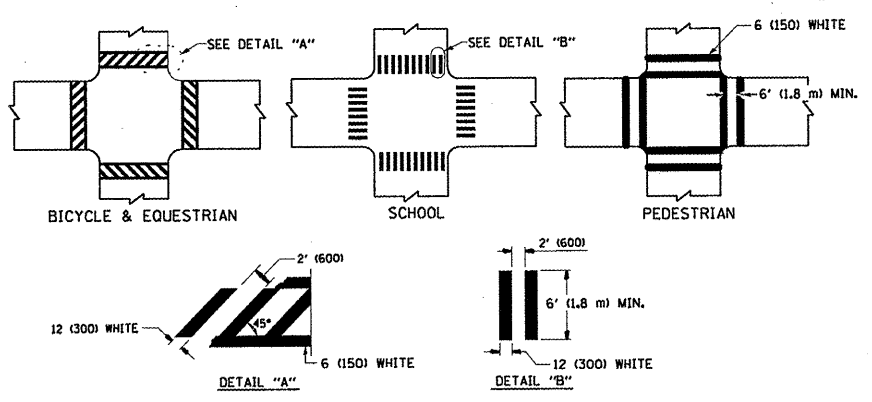

TYPICAL CROSSWALK MARKING

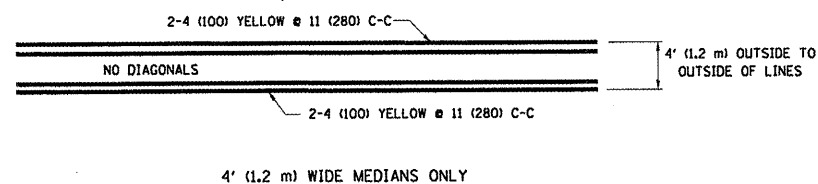

4' (1.2 m) WIDE MEDIANS ONLY

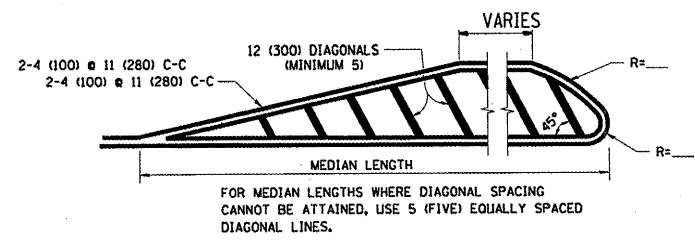

FOR MEDIAN LENGTHS WHERE DIAGONAL SPACING CANNOT BE ATTAINED, USE 5 (FIVE) EQUALLY SPACED DIAGONAL LINES.

DIAGONAL LINE SPACING: 50' (15 m) C-C (LESS THAN 30MPH (50 km/h))
75' (25 m) C-C 30MPH (50 km/h) TO 45MPH (70 km/h)
150' (45 m) C-C (MORE THAN 45MPH (70 km/h))

MEDIANS OVER 4' (1.2 m) WIDE

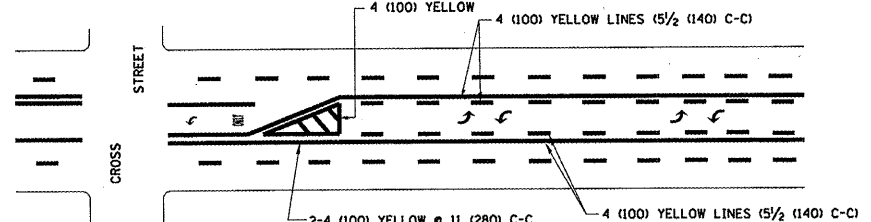

A MINIMUM OF TWO PAIRS OF TURN ARROWS SHALL BE USED, WHITE IN COLOR. ADDITIONAL PAIRS SHALL BE PLACED AT 200' (60 m) TO 300' (90 m) INTERVALS.

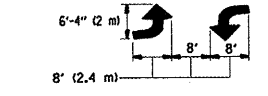

MEDIAN WITH TWO-WAY LEFT TURN LANE

TYPICAL PAINTED MEDIAN MARKING

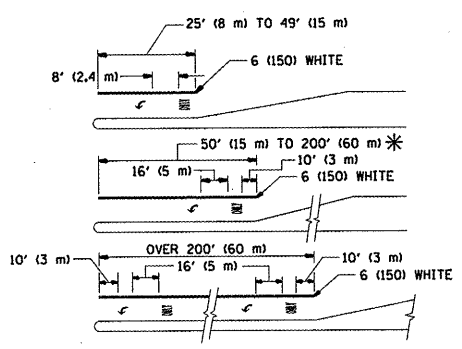

FULL SIZE LETTERS 8' (2.4 m) AND ARROWS SHALL BE USED.
AREA = 15.6 SQ. FT. (1.5 m²) ONLY AREA = 20.8 SQ. FT. (1.9 m²)

* TURN LANES IN EXCESS OF 400' (120 m) IN LENGTH MAY HAVE AN ADDITIONAL SET OF ARROW - "ONLY" INSTALLED MIDWAY BETWEEN THE OTHER TWO SETS OF ARROW - "ONLY".

TYPICAL LEFT (OR RIGHT) TURN LANE

TYPICAL TURN LANE MARKING

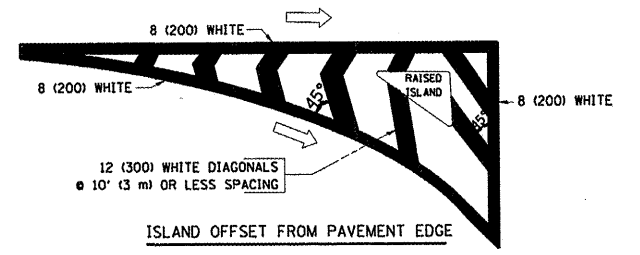

ISLAND OFFSET FROM PAVEMENT EDGE

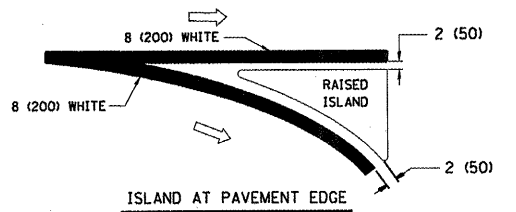

ISLAND AT PAVEMENT EDGE

TYPICAL ISLAND MARKING

TYPE OF MARKING	WIDTH OF LINE	PATTERN	COLOR	SPACING / REMARKS
CENTERLINE ON 2 LANE PAVEMENT	4 (100)	SKIP-DASH	YELLOW	10' (3 m) LINE WITH 30' (9 m) SPACE
CENTERLINE ON MULTI-LANE UNDIVIDED PAVEMENT	2 @ 4 (100)	SOLID	YELLOW	11 (280) C-C
NO PASSING ZONE LINES FOR ONE DIRECTION	4 (100)	SOLID	YELLOW	5 1/2 (140) C-C FROM SKIP-DASH CENTERLINE
NO PASSING ZONE LINES FOR BOTH DIRECTIONS	2 @ 4 (100)	SOLID	YELLOW	11 (280) C-C OMIT SKIP-DASH CENTERLINE BETWEEN
LANE LINES	4 (100) 5 (125) ON FREEWAYS	SKIP-DASH SKIP-DASH	WHITE WHITE	10' (3 m) LINE WITH 30' (9 m) SPACE
DOTTED LINES (EXTENSIONS OF CENTER, LANE OR TURN LANE MARKINGS)	SAME AS LINE BEING EXTENDED	SKIP-DASH	SAME AS LINE BEING EXTENDED	2' (600) LINE WITH 6' (1.8 m) SPACE
EDGE LINES	4 (100)	SOLID	YELLOW-LEFT WHITE-RIGHT	OUTLINE MOUNTABLE MEDIANS IN YELLOW; EDGE LINES ARE NOT USED NEXT TO BARRIER CURB
TURN LANE MARKINGS	6 (150) LINE; FULL SIZE LETTERS & SYMBOLS (8' (2.4m))	SOLID	WHITE	SEE TYPICAL TURN LANE MARKING DETAIL
TWO WAY LEFT TURN MARKING	2 @ 4 (100) EACH DIRECTION 8' (2.4m) LEFT ARROW	SKIP-DASH AND SOLID IN PAIRS	YELLOW WHITE	10' (3 m) LINE WITH 30' (9 m) SPACE FOR SKIP-DASH; 5 1/2 (140) C-C BETWEEN SOLID LINE AND SKIP-DASH LINE. SEE TYPICAL TWO-WAY LEFT TURN MARKING DETAIL
CROSSWALK LINES (PEDESTRIAN) A. DIAGONALS (BIKE & EQUESTRIAN) B. LONGITUDINAL BARS (SCHOOL)	2 @ 6 (150) 12 (300) @ 45° 12 (300) @ 90°	SOLID SOLID	WHITE WHITE WHITE	NOT LESS THAN 6' (1.8 m) APART 2' (600) APART 2' (600) APART SEE TYPICAL CROSSWALK MARKING DETAILS.
STOP LINES	24 (600)	SOLID	WHITE	PLACE 4' (1.2 m) IN ADVANCE OF AND PARALLEL TO CROSSWALK, IF PRESENT. OTHERWISE, PLACE AT DESIRED STOPPING POINT. PARALLEL TO CROSSROAD CENTERLINE, WHERE POSSIBLE
PAINTED MEDIANS	2 @ 4 (100) WITH 12 (300) DIAGONALS @ 45° NO DIAGONALS USED FOR 4' (1.2 m) WIDE MEDIANS	SOLID	YELLOW; TWO WAY TRAFFIC WHITE; ONE WAY TRAFFIC	11 (280) C-C FOR THE DOUBLE LINE. SEE TYPICAL PAINTED MEDIAN MARKING.
GORE MARKING AND CHANNELIZING LINES	8 (200) WITH 12 (300) DIAGONALS @ 45°	SOLID	WHITE	DIAGONALS: 15' (4.5 m) C-C (LESS THAN 30MPH (50 km/h)) 20' (6 m) C-C (30 MPH (50 km/h) TO 45MPH (70 km/h)) 30' (9 m) C-C (OVER 45MPH (70 km/h))
RAILROAD CROSSING	24 (600) TRANSVERSE LINES; "RR" IS 6' (1.8 m) LETTERS; 16 (400) LINE FOR "X"	SOLID	WHITE	SEE STATE STANDARD 780001 AREA OF "R"=3.6 SQ. FT. (0.33 m ²) EACH "X"=54.0 SQ. FT. (5.0 m ²)
SHOULDER DIAGONALS	12 (300) @ 45°	SOLID	WHITE - RIGHT YELLOW - LEFT	50' (15 m) C-C (LESS THAN 30MPH (50 km/h)) 75' (25 m) C-C (30 MPH (50 km/h) TO 45MPH (70 km/h)) 150' (45 m) C-C (OVER 45MPH (70 km/h))

FOR FURTHER DETAILS ON PAVEMENT MARKING REFER TO STANDARD SPECIFICATIONS FOR ROAD AND BRIDGE CONSTRUCTION AND STATE STANDARD 780001.

All dimensions are in inches (millimeters) unless otherwise shown.

FILE NAME =	USER NAME = VelichkovV	DESIGNED - EVERS	REVISED - T. RAMMACHER 10-27-94
cr:\pwork\pwork\velichkovv\d0260110\0	at5std.dgn	DRAWN -	REVISED - C. JUCIUS 09-09-09
PLOT SCALE = 100.0000' / IN.	CHECKED -	REVISOR -	REVISOR -
PLOT DATE = 4/13/2011	DATE - 03-19-90	REVISED -	REVISED -

STATE OF ILLINOIS
DEPARTMENT OF TRANSPORTATION

DISTRICT ONE			
TYPICAL PAVEMENT MARKINGS			
SCALE: NONE	SHEET NO. 1 OF 1 SHEETS	STA.	TO STA.

F.A. RTE.	SECTION	COUNTY	TOTAL SHEETS	SHEET NO.
VAR.	2011-007-RS	LAKE	50	45
TC-13		CONTRACT NO. 60N95		
FED. ROAD DIST. NO. 1 ILLINOIS FED. AID PROJECT				

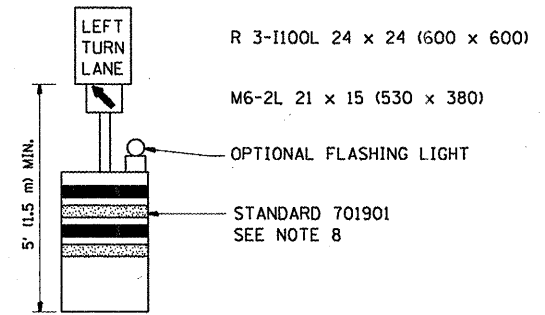
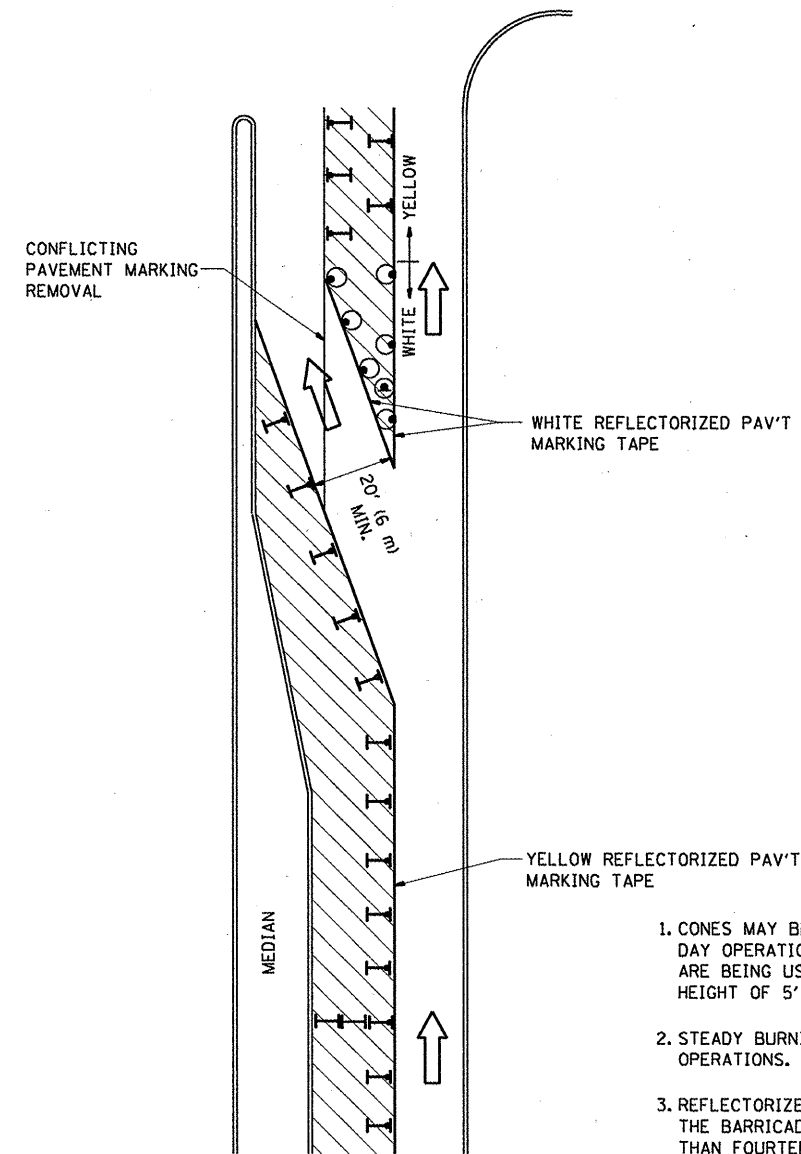

GENERAL NOTES

1. CONES MAY BE SUBSTITUTED FOR BARRICADES OR DRUMS AT HALF THE SPACING DURING DAY OPERATIONS. CONES SHALL BE A MINIMUM OF 28 (710) IN HEIGHT. WHEN CONES ARE BEING USED, THE "LEFT TURN LANE" SIGN MAY BE SKID MOUNTED AT A MINIMUM HEIGHT OF 5' (1.5 m).
2. STEADY BURNING LIGHTS WILL NOT BE REQUIRED ON BARRICADES OR DRUMS FOR DAY OPERATIONS. ALL LIGHTS SHALL BE MONODIRECTIONAL.
3. REFLECTORIZED TEMPORARY PAVEMENT MARKING TAPE SHALL BE PLACED THROUGHOUT THE BARRICADED AREA OF EACH TURN BAY WHERE THE CLOSURE TIME IS GREATER THAN FOURTEEN DAYS.
4. THIS APPLICATION ALSO APPLIES WHEN WORK IS BEING PERFORMED IN THE RIGHT LANE(S) AND THE RIGHT TURN BAY IS TO REMAIN OPEN. UNDER THIS CONDITION, "RIGHT TURN LANE" R3-100 24 x 24 (600 x 600) AND M6-2R 21 x 15 (530 x 380) SHALL BE USED.
5. THESE CONTROLS SHALL SUPPLEMENT MAINLINE TRAFFIC CONTROL FOR LANE CLOSURES.
6. LONGITUDINAL DIMENSIONS MAY BE ADJUSTED TO FIT FIELD CONDITIONS.
7. FORM OPER 725 IS REQUIRED.
8. IF A DRUM OR TYPE II BARRICADE WITH AN ATTACHED SIGN PANEL WHICH MEETS NCHRP 350 REQUIREMENTS IS NOT AVAILABLE, THE SIGNS SHALL BE MOUNTED, ABOVE THE BARRICADES, ON SEPARATE SIGNS SUPPORTS THAT MEET NCHR 350 PREQUIREMENTS.
9. TRAFFIC CONTROL AND PROTECTION AT TURN BAYS (TO REMAIN OPEN TO TRAFFIC) SHALL BE INCLUDED IN THE COST SPECIFIED TRAFFIC CONTROL STANDARDS OR ITEMS.

All dimensions are in inches (millimeters) unless otherwise shown.

LEGEND

- WORK AREA
- LANE OPEN TO TRAFFIC
- TYPE I OR II BARRICADE WITH STEADY BURN LIGHT
- DRUM WITH STEADY BURN LIGHT
- DRUM WITH SIGN (WITH OPTIONAL FLASHING LIGHT) SEE DETAIL
- TYPE I OR II CHECK BARRICADE WITH FLASHING LIGHT

FILE NAME =	USER NAME = VelichkovVV	REVISED -T. RAMMACHER 09-08-94	REVISED - R. BORO 09-14-09
ct:\pw\work\pwsdot\velichkovvv\d026010\Std.dgn		REVISED - A. HOUSEH 11-07-95	REVISED -
PLOT SCALE = 100.0000 "/ IN.		REVISED - A. HOUSEH 10-12-96	REVISED -
PLOT DATE = 4/13/2011		REVISED -T. RAMMACHER 01-06-00	REVISED -

**STATE OF ILLINOIS
DEPARTMENT OF TRANSPORTATION**

**TRAFFIC CONTROL AND PROTECTION AT TURN BAYS
(TO REMAIN OPEN TO TRAFFIC)**

SCALE: NONE SHEET NO. 1 OF 1 SHEETS STA. TO STA.

F.A. RTE.	SECTION	COUNTY	TOTAL SHEETS	SHEET NO.
VAR.	2011-007-RS	LAKE	50	46
TC-14		CONTRACT NO. 60N95		
FED. ROAD DIST. NO. 1 ILLINOIS FED. AID PROJECT				

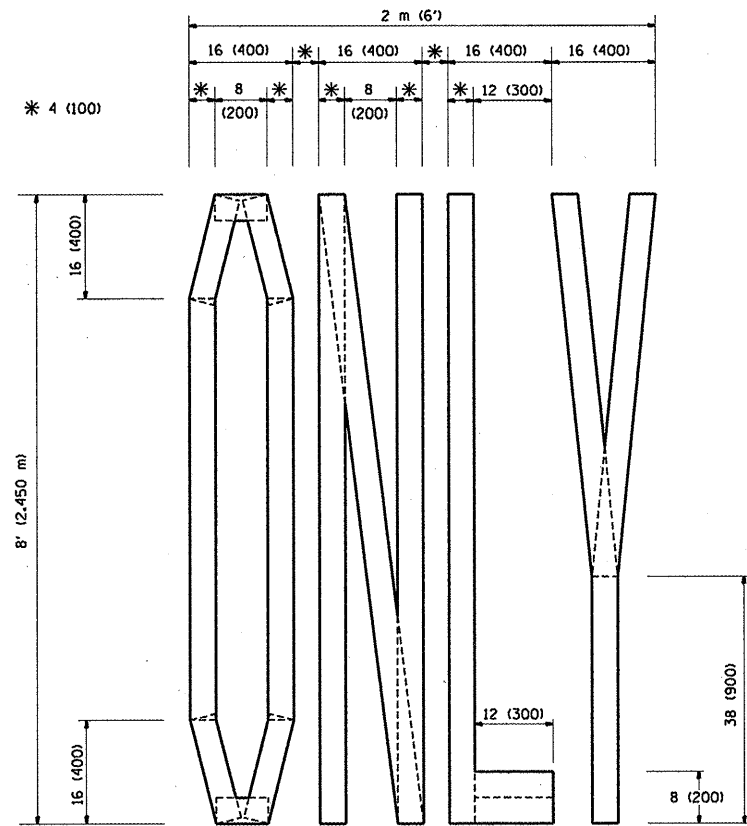

QUANTITY
4 (100) LINE = 64.1 ft. (19.7 m)
21.1 sq. ft. (1.97 sq. m)

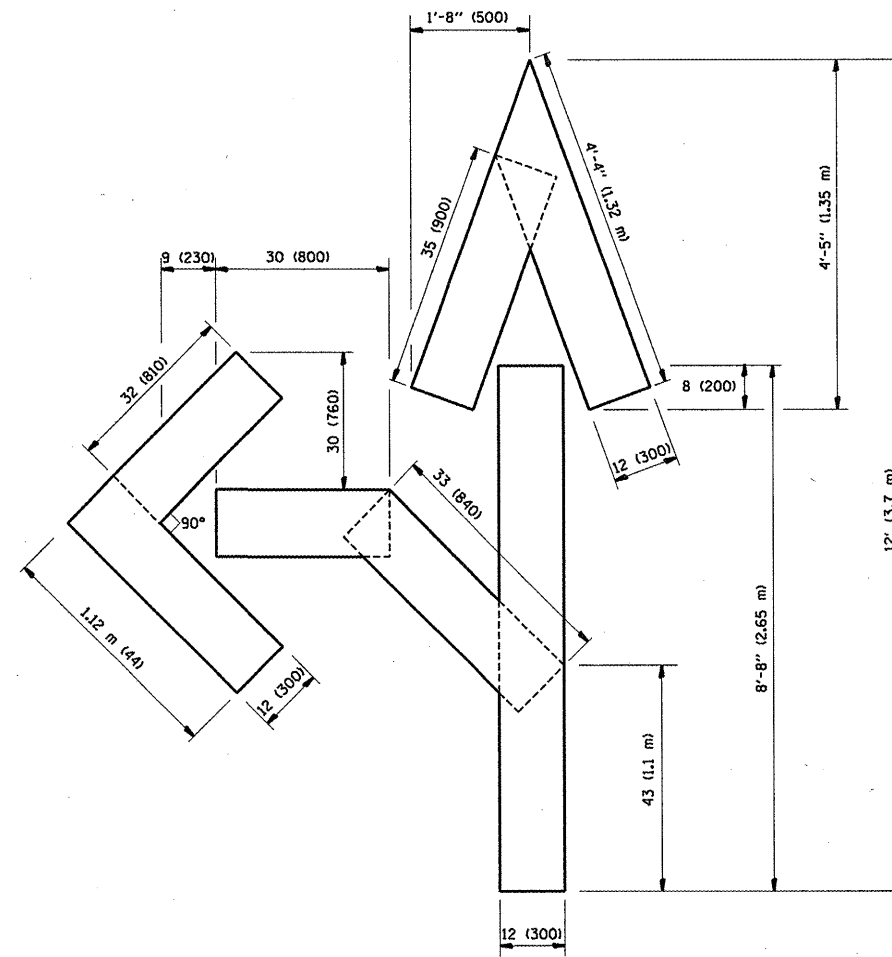

QUANTITY
4 (100) LINE = 82.5 ft. (25.3 m)
27.5 sq. ft. (2.53 sq. m)

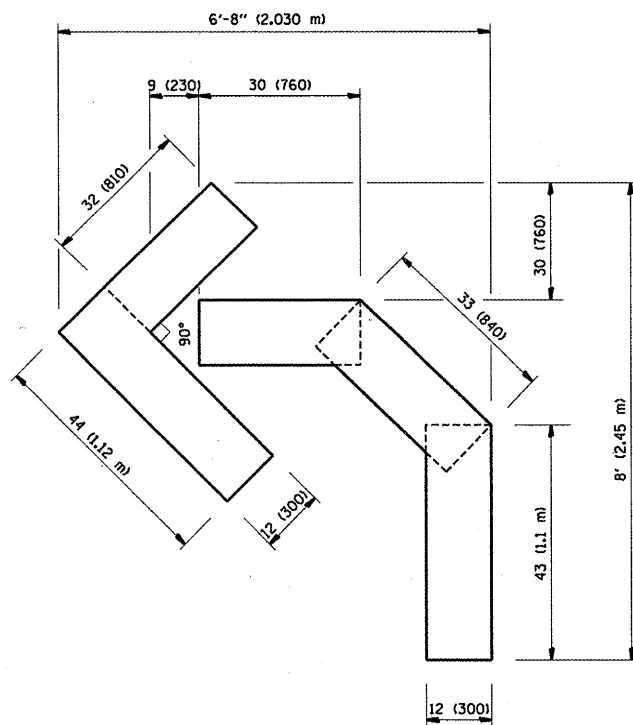

QUANTITY
4 (100) LINE = 45.5 ft. (13.9 m)
15.2 sq. ft. (1.39 sq. m)

All dimensions are in inches (millimeters) unless otherwise shown.

FILE NAME =	USER NAME = VelschkovVV	DESIGNED -	REVISED -T. RAMMACHER 06-05-96
c:\pw\work\pwwork\velschkov\0260110\01	et3td.dgn	DRAWN -	REVISED -T. RAMMACHER 11-04-97
PLOT SCALE = 100.00000 ' / IN.		CHECKED -	REVISED -T. RAMMACHER 03-02-98
PLOT DATE = 4/13/2011		DATE - 09-18-94	REVISED -E. GOMEZ 08-28-00

STATE OF ILLINOIS
DEPARTMENT OF TRANSPORTATION

PAVEMENT MARKING LETTERS AND SYMBOLS
FOR TRAFFIC STAGING

SCALE: NONE SHEET NO. 1 OF 1 SHEETS STA. TO STA.

F.A. RTE.	SECTION	COUNTY	TOTAL SHEETS	SHEET NO.
VAR.	2011-007-RS	LAKE	50	47
TC-16		CONTRACT NO. 60N95		
FED. ROAD DIST. NO. 1 ILLINOIS FED. AID PROJECT				

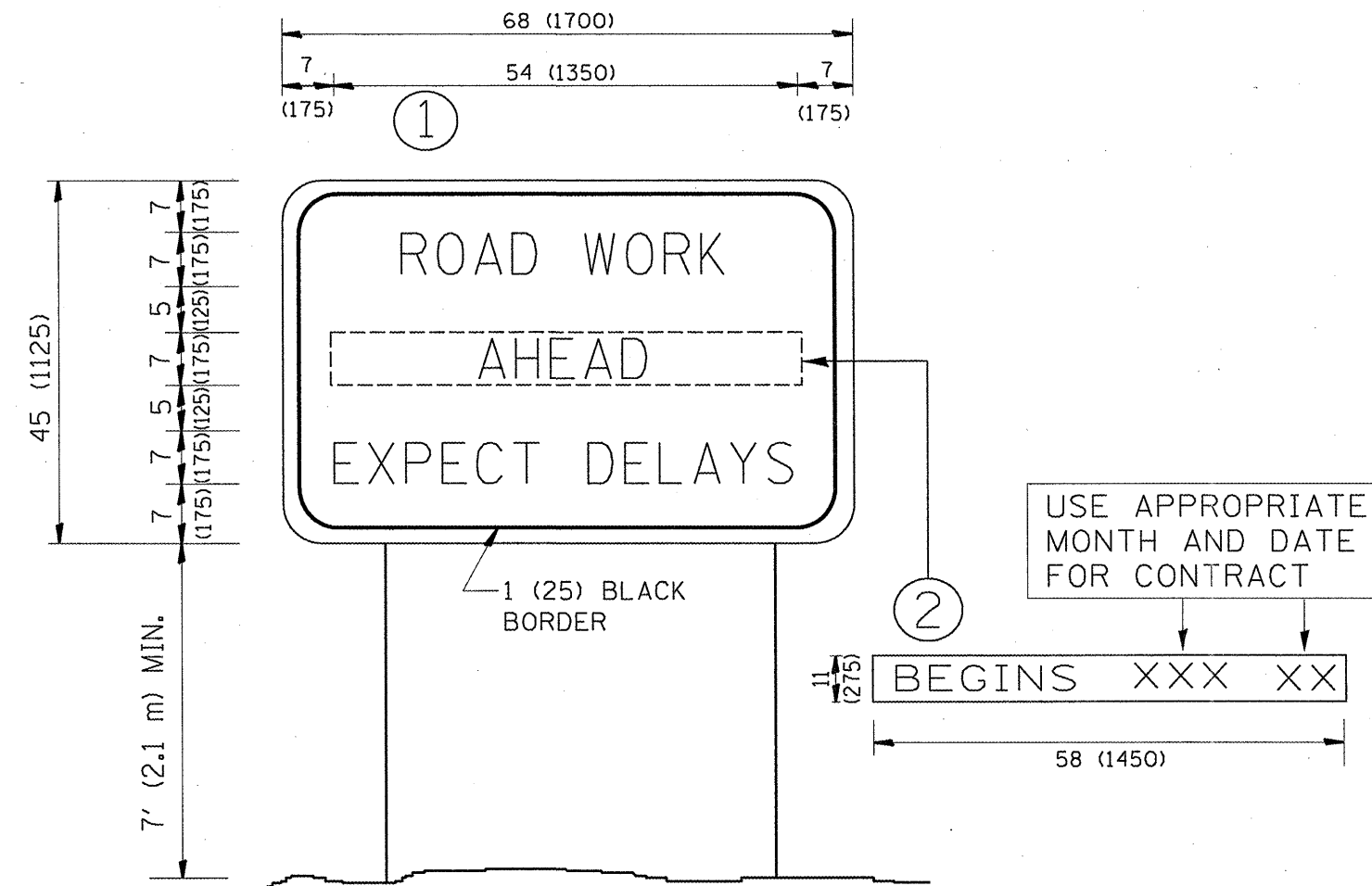

NOTES:

1. USE BLACK LETTERING ON ORANGE BACKGROUND.
2. ERECT SIGNS IN ADVANCE OF THE LOCATION FOR THE "ROAD CONSTRUCTION AHEAD" SIGN AT LOCATIONS AS DIRECTED BY THE ENGINEER.
3. ERECT SIGN ① WITH INSTALLED PANEL ② ONE WEEK PRIOR TO THE START OF CONSTRUCTION.
4. REMOVE PANEL ② SOON AFTER THE START OF CONSTRUCTION.
5. SEE SPECIAL PROVISION FOR "TEMPORARY INFORMATION SIGNING" FOR ADDITIONAL INFORMATION.
6. ONE SIGN ASSEMBLY EQUALS 25.70 SQ. FT. (2.3 SQ. M.)
7. SHALL BE PAID FOR AS TEMPORARY INFORMATION SIGNING.

ALL DIMENSIONS ARE IN INCHES (MILLIMETERS) UNLESS OTHERWISE SHOWN.

FILE NAME =	USER NAME = ValschkovVV	DESIGNED -	REVISED - R. MIRS 09-15-97
ct:\pw_work\pwsdot\valschkovvv\d0260110\d	stStd.dgn	DRAWN -	REVISED - R. MIRS 12-11-97
	PLOT SCALE = 100.0000' / IN.	CHECKED -	REVISED - T. RAMMACHER 02-02-99
	PLOT DATE = 4/13/2011	DATE -	REVISED - C. JUCIUS 01-31-07

**STATE OF ILLINOIS
DEPARTMENT OF TRANSPORTATION**

**ARTERIAL ROAD
INFORMATION SIGN**

SCALE: NONE SHEET NO. 1 OF 1 SHEETS STA. TO STA.

F.A. RTE.	SECTION	COUNTY	TOTAL SHEETS	SHEET NO.
VAR.	2011-007-RS	LAKE	50	48
	TC-22	CONTRACT NO.	60N95	
FED. ROAD DIST. NO. 1 ILLINOIS FED. AID PROJECT				

LOOP DETECTOR NOTES

- EACH PAIR OF LOOP WIRES SHALL BE PLACED IN A SEPARATE EMPTY COILABLE NONMETALLIC CONDUIT FROM THE EDGE OF PAVEMENT TO THE HANDHOLE. SPACING BETWEEN THE HOLES DRILLED IN THE PAVEMENT SHALL NOT BE LESS THAN 6" (150 mm). EMPTY COILABLE NONMETALLIC CONDUIT SHALL BE INCLUDED IN THE COST OF THE LOOP WIRE.
- THE NUMBER OF LOOP TURNS SHALL BE AS RECOMMENDED BY THE AMPLIFIER MANUFACTURER. ALL ADJACENT SIDES OF THE LOOPS SHALL BE INSTALLED IN SUCH A WAY THAT THE CURRENT FLOW IS IN THE SAME DIRECTION TO REINFORCE ITS MAGNETIC FIELDS FOR SMALL VEHICLE DETECTION.
- EACH LOOP LEAD-IN SHALL BE IDENTIFIED AND PERMANENTLY TAGGED IN THE HANDHOLE. EACH LEAD-IN CABLE TAG SHALL INDICATE THE LOCATION OF THE LOOP, LOOP ROTATION (CLOCKWISE/COUNTERCLOCKWISE), LOOP LEAD-IN DIRECTION (IN OR OUT), LOOP CABLE NUMBER AND LOCATION IN CABINET, AND NUMBER OF TURNS IN THE DETECTOR LOOPS IN WATER PROOF INK AS INDICATED ON THE DISTRICT 1 STANDARD TRAFFIC SIGNAL DESIGN DETAIL. THE CONTRACTOR SHALL MARK LOOP LOCATIONS ON RECORD DRAWINGS AND PRESENT TO THE ENGINEER AFTER FINAL INSPECTION. LOOPS SHALL BE MARKED BY LANE AND LOOP NUMBER. SEE DETAIL BELOW.
- ALL LOOP CABLE SHALL BE FASTENED WITH PLASTIC TIE WRAP TO THE HANDHOLE HOOKS.
- IN ASPHALT PAVEMENT, LOOPS SHOULD BE PLACED IN THE BINDER AND DIVEHOLES MARKED AT THE CURB WITH A SAW-CUT. THE SAW-CUT SHALL BE CUT IN ACCORDANCE WITH LOCAL AND E.P.A. DUST CONTROL REQUIREMENTS. DETECTOR LOOP(S) SHALL NOT BE INSTALLED IN WET CONDITIONS AND THE SAW-CUTS MUST BE FREE OF DEBRIS AND RESIDUE SUCH AS DUST AND WATER WHICH IS TO BE ACHIEVED BY THE USE OF COMPRESSED AIR, WIRE BRUSHING AND HEAT DRYING ACCORDING TO SEALANT MANUFACTURER REQUIREMENTS. THE DETECTOR WIRE SHALL BE HELD IN PLACE BY THE USE OF FORM WEDGES. WEDGES SHALL BE SPACED NO MORE THAN 18" (450 mm) APART.
- LOOP SPLICES SHALL BE SOLDERED USING A SOLDERING IRON. BLOW TORCHES OR OTHER DEVICES WHICH OXIDIZE COPPER CABLE SHALL NOT BE ALLOWED FOR SOLDERING OPERATIONS. SEE DETAIL BELOW RIGHT.
- PREFORMED DETECTOR LOOPS SHALL BE USED, AS SHOWN ON THE PLANS, WHERE NEW CONCRETE PAVEMENT IS PROPOSED. THE INSTALLATION OF PREFORMED LOOPS SHALL BE IN ACCORDANCE WITH THE DISTRICT 1 SPECIFICATIONS OR AS DIRECTED BY THE ENGINEER.

LOOP LEAD-IN CABLE TAG

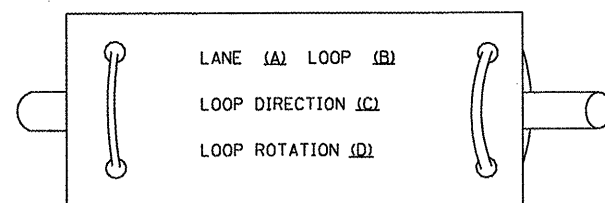

- LANE 1 IS THE LANE CLOSEST TO THE CENTERLINE OF THE ROADWAY
- LOOP #1 IS THE LOOP IN THE LANE CLOSEST TO THE INTERSECTION.
- LABEL LOOP CABLE "IN" OR LOOP CABLE "OUT".
- LABEL LOOP CABLE CLOCKWISE OR LOOP CABLE COUNTERCLOCKWISE.

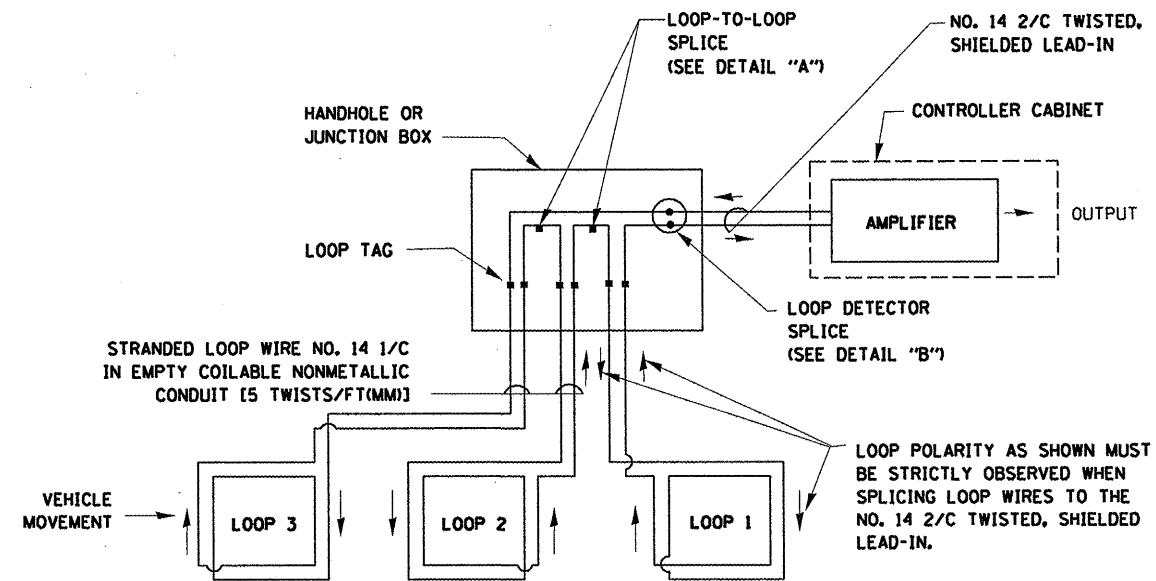

DETECTOR LOOP WIRING SCHEMATIC

- LOOPS SHALL BE SPLICED IN SERIES.
- SAW-CUTS SHALL BE A MINIMUM WIDTH OF 5/16" (8 mm).
- SAW-CUT DEPTHS SHALL BE 3" (75 mm). IF IN CONCRETE, THE SAW-CUT DEPTH SHALL BE TO THE TOP OF THE REINFORCEMENT.
- LOOP CORNERS SHALL BE DRILLED WITH A 2" (50 mm) DIAMETER CORE.

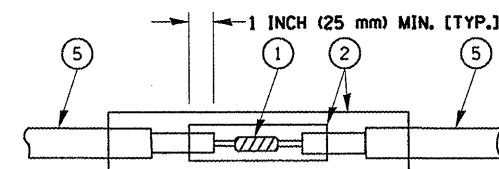

DETAIL "A"
LOOP-TO-LOOP SPLICE

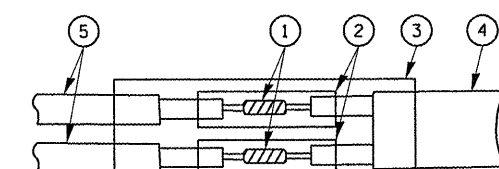

DETAIL "B"
LOOP-TO-CONTROLLER SPLICE

TYPE I LOOP

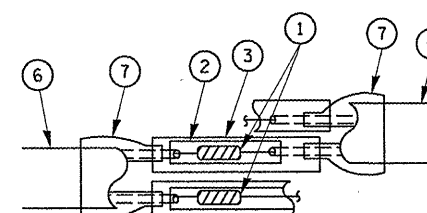

DETAIL "A"
LOOP-TO-LOOP SPLICE

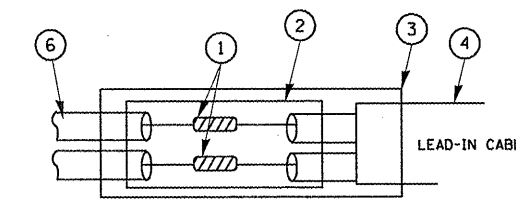

DETAIL "B"
LOOP-TO-CONTROLLER SPLICE

LOOP DETECTOR SPLICE

- WESTERN UNION SPLICE SOLDERED WITH ROSIN CORE FLUX. ALL EXPOSED SURFACES OF THE SOLDER SHALL BE SMOOTH.
- WCSMW 30/100 HEAT SHRINK TUBE, MINIMUM LENGTH 3" (75 mm), UNDERWATER GRADE.
- WCS 200/750 HEAT SHRINK TUBE, MINIMUM LENGTH 6" (150 mm), UNDERWATER GRADE.
- NO. 14 2/C TWISTED, SHIELDED CABLE.
- LOOP CONDUCTOR WITH FLEXIBLE PLASTIC TUBE.
- PREFORMED LOOP
- XL POLYOLEFIN 2 CONDUCTOR BREAKOUT SEALS. TYCO CBR-2 OR APPROVED EQUAL

FILE NAME =	USER NAME = VelichkovVV	DESIGNED - DAD	REVISED -	STATE OF ILLINOIS DEPARTMENT OF TRANSPORTATION	DISTRICT ONE STANDARD TRAFFIC SIGNAL DESIGN DETAILS			F.A. RTE.	SECTION	COUNTY	TOTAL SHEETS	SHEET NO.	
cr\pw_work\p\midot\velichkovvv\d0260110\	etStd.dgn	DRAWN - BCK	REVISED -		SCALE: NONE	SHEET NO. 1 OF 6 SHEETS	STA.	TO STA.	VAR.	2011-007-RS	LAKE	50	49
		CHECKED - DAD	REVISED -							TS-05			CONTRACT NO. 60N95
		DATE - 10-28-09	REVISED -							FED. ROAD DIST. NO. 1 ILLINOIS FED. AID PROJECT			

LOOPS NEXT TO SHOULDERS

PROVIDE A PAVEMENT REPLACEMENT NOTE WHICH SHOULD EQUAL 3' (900 mm) X WIDTH OF PAVED SHOULDER.

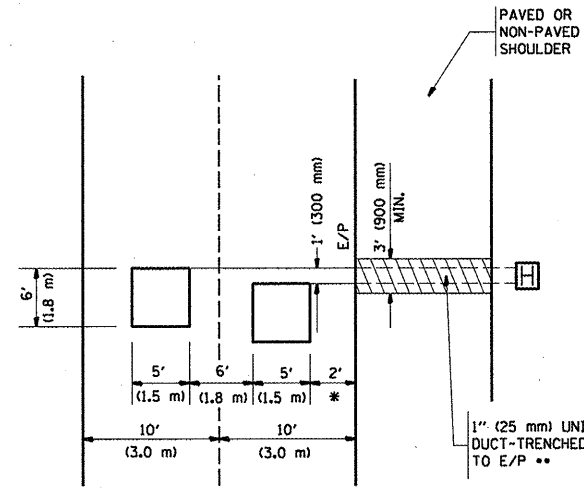

* = (600 mm)

** UNIT DUCT IS TO BE SHOWN ON PLAN SHEETS BUT SHALL NOT BE INCLUDED IN THE PAY ITEMS.

**LEFT TURN LANES WITH MEDIANS
VOLUME DENSITY ("FAR OUT" DETECTION)
ON SAME APPROACH
(PROTECTED / PERMITTED LEFT TURN PHASING)**

HANDHOLE LOCATION MAY VARY DEPENDING ON GEOMETRICS AND DESIGN OF TRAFFIC SIGNALS. HEAVY-DUTY HANDHOLES TO BE USED WHEN THE MEDIAN IS MOUNTABLE. REFER TO STANDARD 814001 TO ENSURE THAT HANDHOLE FITS IN MEDIAN.

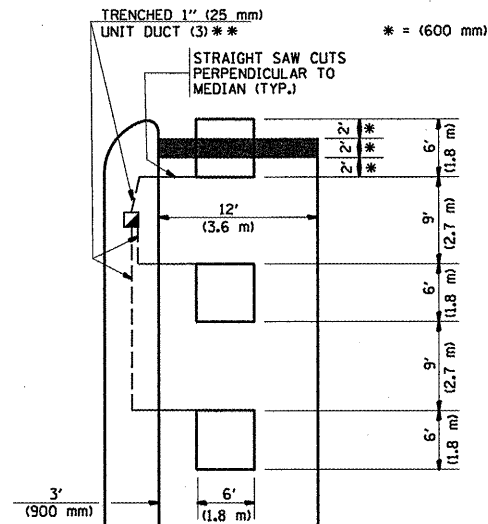

** UNIT DUCT IS TO BE SHOWN ON PLAN SHEETS BUT SHALL NOT BE INCLUDED IN THE PAY ITEMS.

NOTE: DUAL LEFT TURNS NOT SHOWN REFER TO PLAN SHEET FOR DETECTOR LOOP REPLACEMENT

**LEFT TURN LANES WITHOUT MEDIANS
VOLUME DENSITY ("FAR OUT" DETECTION)
ON SAME APPROACH
(PROTECTED / PERMITTED LEFT TURN PHASING)**

* = (600 mm)

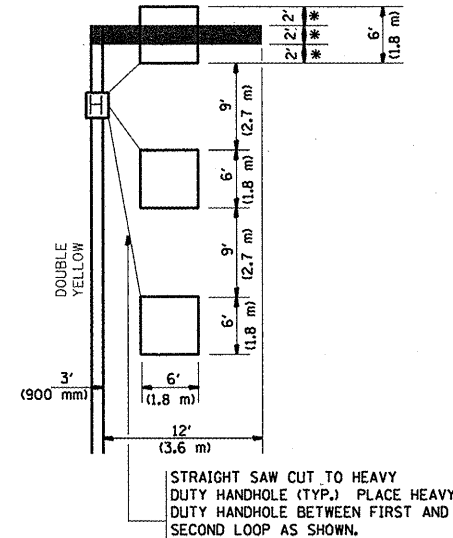

NOTE: DUAL LEFT TURNS NOT SHOWN REFER TO PLAN SHEET FOR DETECTOR LOOP REPLACEMENT

**ARTERIAL-VOLUME DENSITY ("FAR OUT" DETECTION)
CROSS STREET-VOLUME DENSITY ("FAR OUT" DETECTION)**

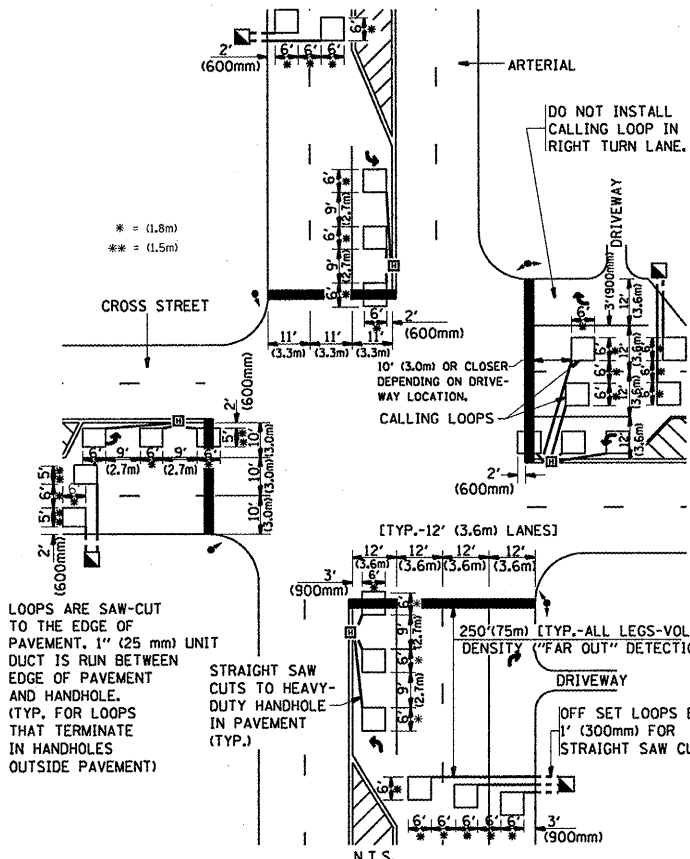

**DETAIL 1
N.T.S.**

**ARTERIAL-VOLUME DENSITY ("FAR OUT" DETECTION)
CROSS STREET-NON VOLUME DENSITY ("UPTIGHT" PRESENCE DETECTION)**

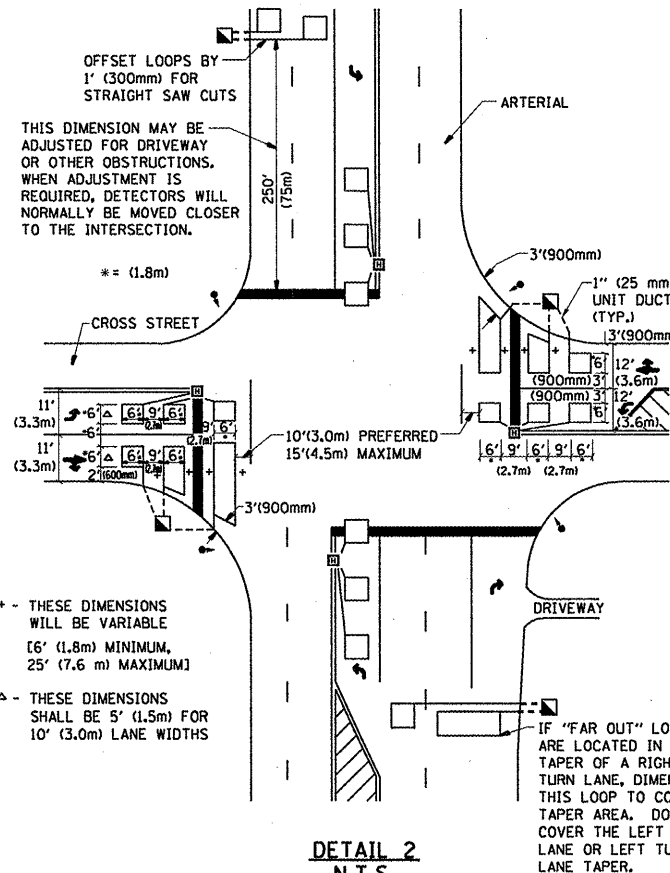

**DETAIL 2
N.T.S.**

NOTES:

VEHICLES LOOP DETECTORS

- * ALL LEAD IN CABLE SHALL BE TWO CONDUCTOR NO. 14 TWISTED, SHIELDED.
- * EACH DETECTOR LOOP SHALL HAVE ITS OWN SAW CUT FROM THE LOOP TO THE EDGE OF PAVEMENT OR TO A HANDHOLE IN THE PAVEMENT.
- * EACH DETECTOR LOOP SHALL HAVE ITS OWN ONE INCH (25 mm) UNIT DUCT BETWEEN THE EDGE OF PAVEMENT AND THE FIRST HANDHOLE OR JUNCTION BOX. EACH UNIT DUCT RUN SHALL BE SHOWN ON THE PLANS BY THE DESIGNER, BUT SHALL NOT BE PAID FOR SEPARATELY. THIS ITEM IS INCIDENTAL TO THE PAY ITEM FOR DETECTOR LOOPS.
- * ONE DIMENSION OF ALL DETECTOR LOOPS SHALL BE SIX FEET (1.8 m)
- * EACH LANE OF NON-LOCKING, PRESENCE DETECTION AND EACH LANE OF A DOUBLE LEFT TURN LANE REQUIRES A SEPARATE INDUCTIVE LOOP DETECTOR AND LEAD IN CABLE.
- * WHEN NON-LOCKING, PRESENCE DETECTION IS USED, MORE THAN ONE LOOP PER LANE IS REQUIRED BEHIND THE STOP BAR (i.e. 1-1/2, 1-3/4, 2).
- * WHEN SYSTEM LOOPS ARE REQUIRED ON AN APPROACH OF AN INTERSECTION, THE LOOPS USED FOR VOLUME DENSITY AND INTERSECTION TIMING SHALL ALSO BE USED AS SYSTEM DETECTORS. EACH ONE OF THESE TYPE OF LOOPS REQUIRES A SEPARATE TWO CONDUCTOR NO. 14 TWISTED SHIELDED CABLE AND A SEPARATE INDUCTIVE LOOP DETECTOR WHEN NEW CONTROLLERS ARE UTILIZED. THE DESIGNER SHALL LABEL THESE TYPES OF LOOPS AS "INTERSECTION AND SAMPLING (SYSTEM) DETECTORS" ON THE SIGNAL LAYOUT, THE INTERCONNECT PLAN AND THE SYSTEM CABLE PLAN. WHEN AN EXISTING CONTROLLER IS UTILIZED FOR THIS TYPE OF DETECTION, THE PAY ITEM "INDUCTIVE LOOP DETECTOR WITH SYSTEM OUTPUT" SHOULD BE USED.

PLACEMENT OF DETECTORS

THE FOLLOWING FIGURES REPRESENT THE MOST COMMON DETECTOR LOOP LOCATIONS AND SIZES. ADJUSTMENTS WILL BE NECESSARY FOR SPECIFIC GEOMETRIC CONSIDERATIONS.

LOCATIONS AND DEMENSIONS OF DETECTOR LOOPS ARE REQUIRED ON ALL SIGNAL LAYOUT PLAN SHEETS.

"FAR OUT" DETECTION REFERS TO LOCKING, PRESENCE TYPE DETECTION LOCATED IN THRU LANES, RIGHT TURN LANES, AND RIGHT TURN LANE TAPER AREAS (IF APPLICABLE), USUALLY 250' (75 m) IN ADVANCE OF STOP BARS. "UPTIGHT" DETECTION REFERS TO NON-LOCKING PRESENCE TYPE DETECTION LOCATED IN ALL LANES AND 10'-15' (3.0 m-4.5 m) BEHIND THE CROSSING STREET'S EDGE OF PAVEMENT EXTENDED.

NOTE:

ALL DETAILS AND NOTES SHOWN ARE FROM THE I.D.O.T. DISTRICT 1 TRAFFIC SIGNAL DESIGN GUIDELINES DATED JANUARY 1995

THIS DRAWING HAS BEEN PREPARED TO ASSIST THE RESIDENT ENGINEER FOR ALL ROADWAY RESURFACING OR S.M.A.R.T. PROJECTS WHERE THE DIMENSIONS ARE NOT SHOWN ON THE PLANS AND THE FINAL LOCATIONS FOR CROSSWALKS OR STOP BARS ARE NOT DETERMINED.

FILE NAME =	USER NAME = Veliachkov	DESIGNED -	REVISED -	STATE OF ILLINOIS DEPARTMENT OF TRANSPORTATION	DISTRICT 1 - DETECTOR LOOP INSTALLATION DETAILS FOR ROADWAY RESURFACING			F.A. RTE. VAR.	SECTION	COUNTY	TOTAL SHEETS	SHEET NO.	
ca\pwwork\pwwork\velichkov\10260110\10260110.dgn	10260110.dgn	DRAWN -	REVISED -		SCALE: NONE	SHEET NO. 1 OF 1 SHEETS	STA.	TO STA.	2011-007-RS	LAKE	50	50	
PLOT SCALE = 100.0000 / IN.		CHECKED - R.K.F.	REVISED -						TS-07				
PLOT DATE = 4/13/2011		DATE	REVISED -						FED. ROAD DIST. NO. 1	ILLINOIS	FED. AID PROJECT		