

EXISTING TYPICAL CROSS SECTION  
STA. 65+21 TO 115+20

**LEGEND:**

- ① EXIST. P.C.C. PAVEMENT, ±10"
  - ② EXIST. HOT-MIX ASPHALT SURFACE, ±3"
  - ③ EXIST. CORRUGATED MEDIAN
  - ④ EXIST. COMB. CONC. CURB AND GUTTER, TYPE B-6.12
  - ⑤ EXIST. P.C.C. SIDEWALK
  - ⑥ EXIST. STABILIZED SUB-BASE
  - ⑦ PROP. P.C.C. SURFACE REMOVAL, VARIABLE DEPTH
  - ⑧ PROP. HOT-MIX ASPHALT SURFACE REMOVAL, 2 1/4"
  - ⑨ PROP. POLYMERIZED LEVELING BINDER (MACHINE METHOD), IL-4.75, N50, 3/4"
  - ⑩ PROP. POLYMERIZED HOT-MIX ASPHALT SURFACE COURSE, MIX "D", N70, 1 1/2"
- R SIDEWALK, CURB AND GUTTER REMOVAL AND REPLACEMENT  
(LOCATION AS DIRECTED BY THE ENGINEER)

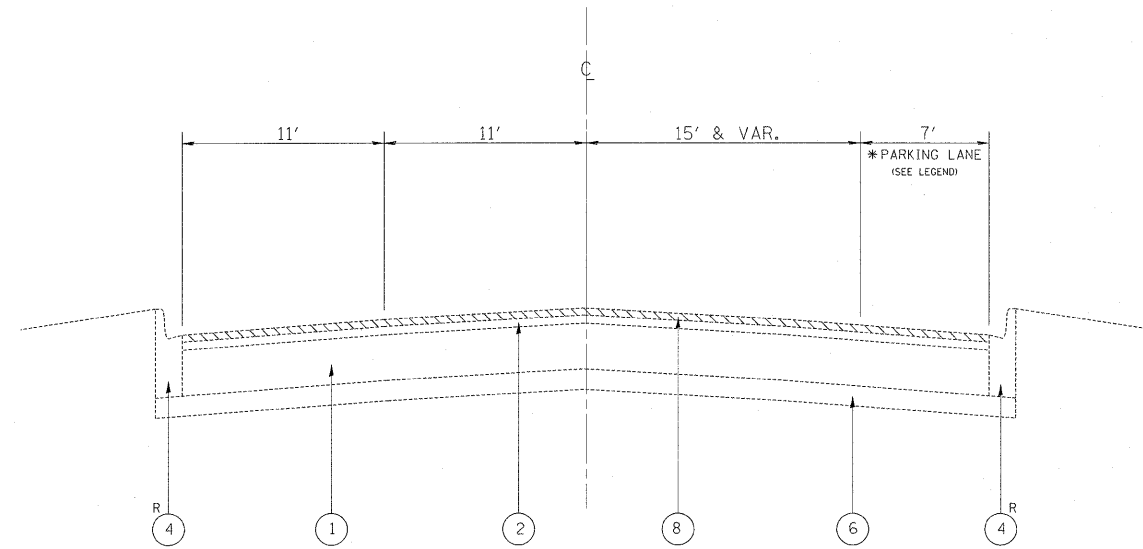

EXISTING TYPICAL CROSS SECTION  
STA. 129+15 TO 157+34

**LEGEND:**

- \* RESIDENTIAL PARKING  
STA. 129+15 TO 135+69  
STA. 144+33 TO 147+51
- PUBLIC PARKING  
STA. 152+73 TO 157+01

FILE NAME =  
0129101-sht-plen.dgn

USER NAME = steedpa  
PLOT SCALE = 50.7684' / IN.  
PLOT DATE = 3/25/2011

DESIGNED -  
DRAWN -  
CHECKED -  
DATE -

REVISED -  
REVISED -  
REVISED -  
REVISED -

**STATE OF ILLINOIS  
DEPARTMENT OF TRANSPORTATION**

EXISTING AND PROPOSED TYPICAL SECTIONS  
F.A.U. 3597 (PARK AVE.)--167th ST. TO 154th ST.

SCALE: NONE SHEET NO. OF SHEETS STA. TO STA.

F.A.U. RTE.	SECTION	COUNTY	TOTAL SHEETS	SHEET NO.
3597	(B,R,&S) RS-5	COOK	28	4
			CONTRACT NO. 62251	
ILLINOIS FED. AID PROJECT				