

PLAN
FOR LOCATION SEE DRAINAGE PLANS

ENCASEMENT DETAILS			
DROP M.H. LOCATION STA., OFFSET			
INV. "A"			
INLET PIPE			
INV. "B"			
INV. "C"			
A			
B			
"V" BAR LENGTH			
NO. OF "U" BARS			
REINF. BARS			
CLASS "SI" CONC. CUBIC YARD			

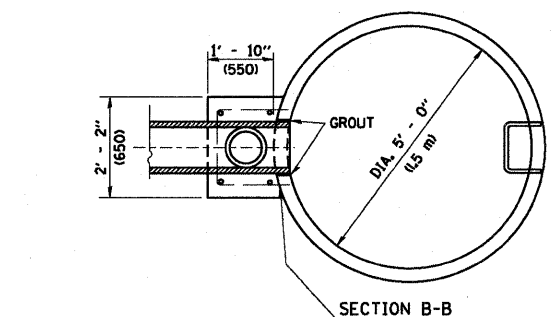

DRILL 1/4" (30) HOLE IN MANHOLE RISER WALLS, FILL WITH MORTAR AND INSERT DOWELS. (TYPICAL FOR ALL DOWELS)

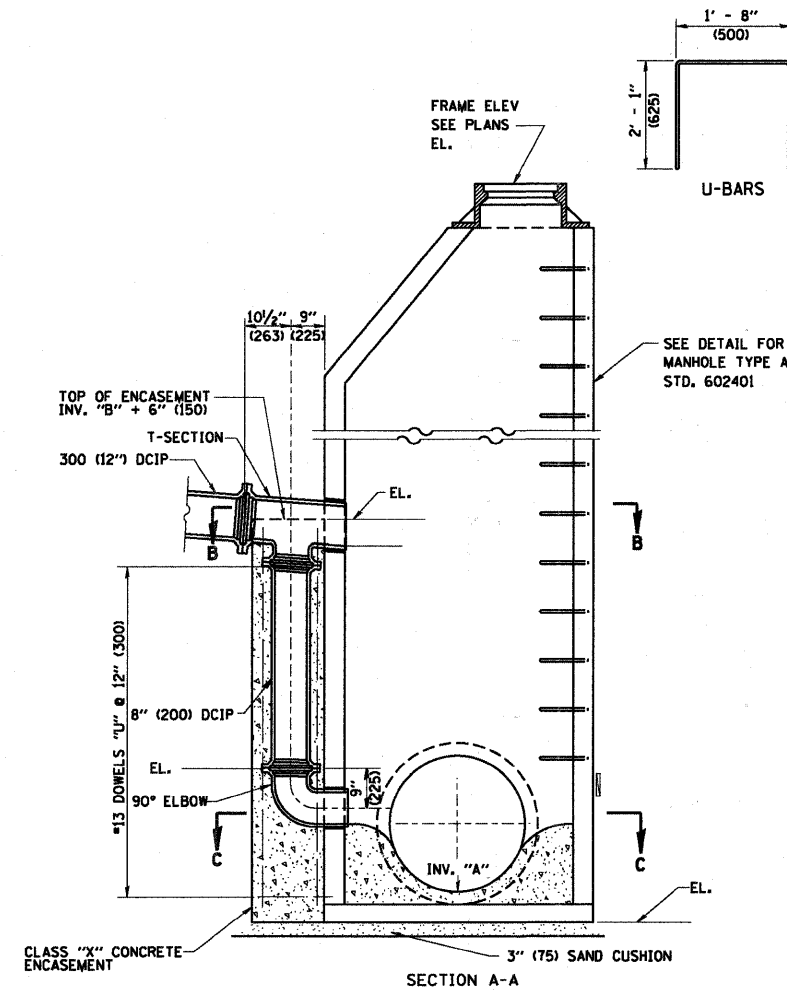
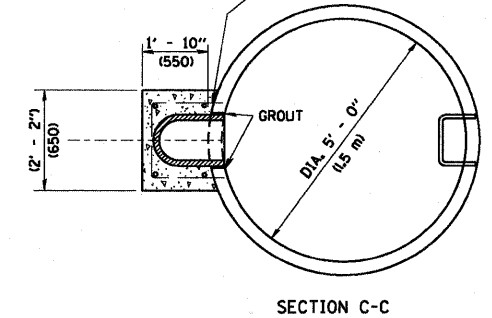

- TYPE A1-1 MANHOLE WITH 1 DROP AND DEPTH UP TO 10' (3 m)
- TYPE A1-2 " " " " " " FROM 10' TO 15' (3 m TO 1.5 m)
- TYPE A1-3 " " " " " " FROM 15' TO 20' (1.5 m TO 6 m)
- TYPE A1-4 " " " " " " OVER 20' (6 m)

- TYPE A2-1 MANHOLE WITH 2 DROPS AND DEPTH UP TO 10' (3 m)
- TYPE A2-2 " " " " " " FROM 10' TO 15' (3 m TO 1.5 m)
- TYPE A2-3 " " " " " " FROM 15' TO 20' (1.5 m TO 6 m)
- TYPE A2-4 " " " " " " OVER 20' (6 m)

ALL DIMENSIONS ARE IN INCHES (MILLIMETERS) UNLESS OTHERWISE SHOWN

FILE NAME = W:\distatd\22x34\bd16.dgn	USER NAME = gaglienabt	DESIGNED -	REVISED -	STATE OF ILLINOIS DEPARTMENT OF TRANSPORTATION	DROP MANHOLE DETAILS			F.A. RTE.	SECTION	COUNTY	TOTAL SHEETS	SHEET NO.
		DRAWN -	REVISED -		SCALE: NONE	SHEET NO. 1 OF 1 SHEETS	STA.	TO STA.	08-00355-00-BR	McHENRY	69	58
		CHECKED -	REVISED -						BD600-05	(BD-16)	CONTRACT NO. 63583	
		DATE - 10-18-02	REVISED -						FED. ROAD DIST. NO. 1 ILLINOIS FED. AID PROJECT			