

OFFSETS TO FACE OF RAIL

Post	X ^m (ft)	Y ^m (ft)
①	11.345 (37.22)	1.22 (4.0)
②	9.475 (31.09)	0.850 (2.79)
③	7.595 (24.92)	0.545 (1.79)
④	6.335 (20.79)	0.380 (1.25)
⑤	5.070 (16.64)	0.245 (0.80)
⑥	3.805 (12.49)	0.135 (0.45)
⑦	1.905 (6.25)	0.035 (0.11)
⑧	0 (0.00)	0 (0.00)

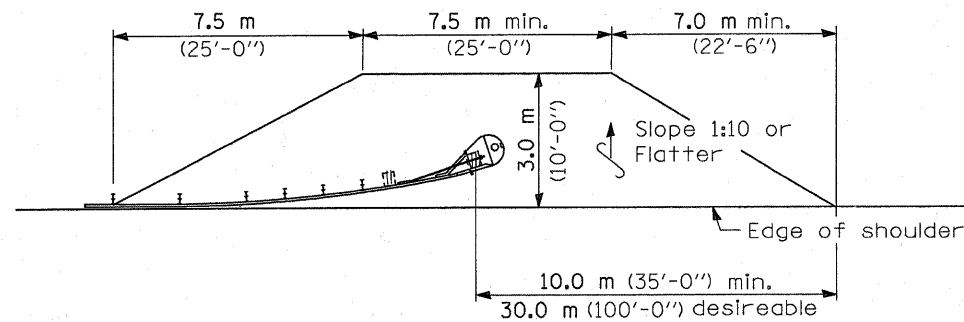

SHOULDER WIDENING TRANSITION

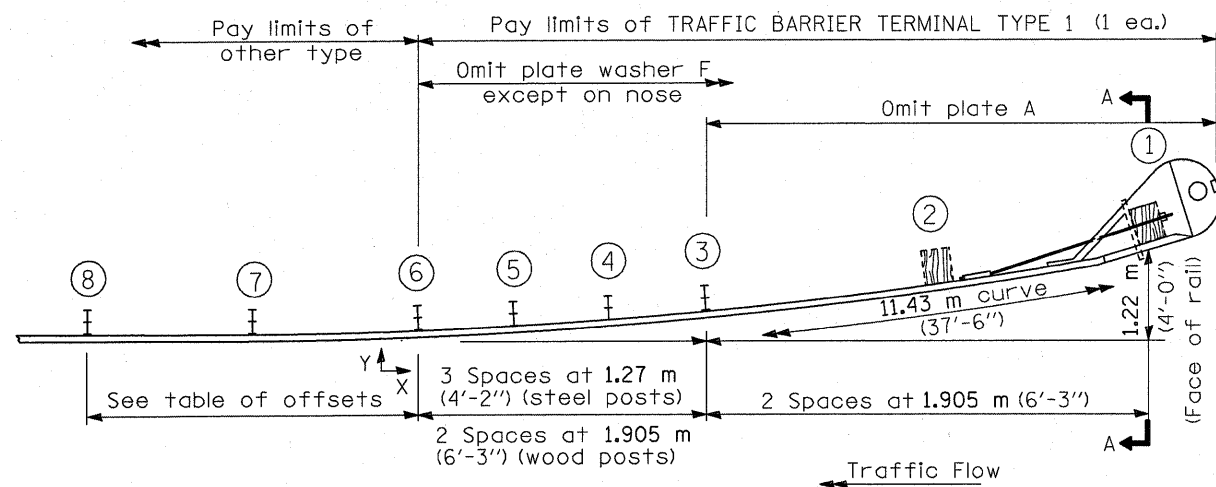

PLAN

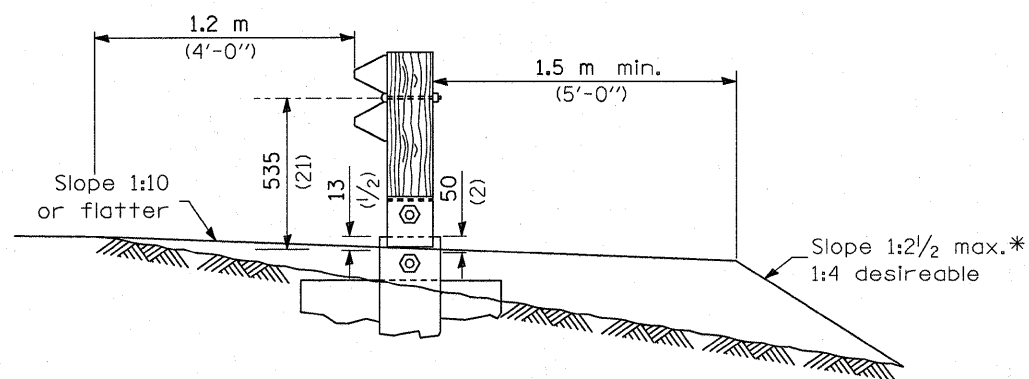

SECTION A-A

* If fill height exceeds 1.5 m (5'-0") use 1:3 max.

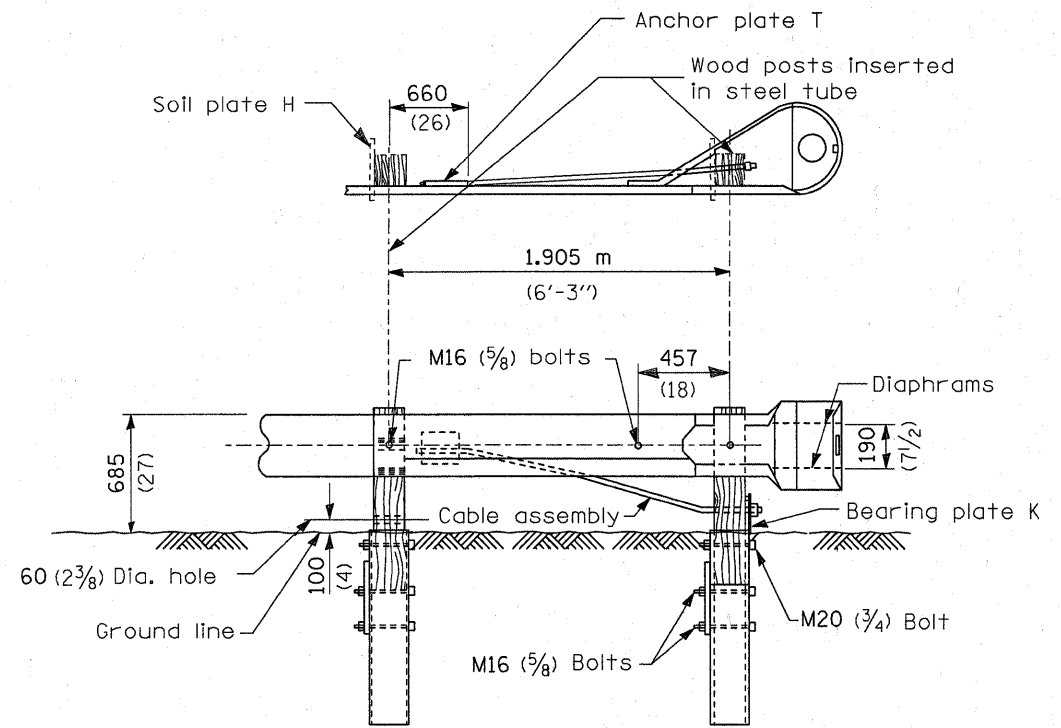

WOOD BREAKAWAY POSTS
TUBULAR STEEL FOUNDATIONS

GENERAL NOTES

See Standard 630001 for details of guardrail not shown.

Posts at location 1 & 2 shall be wood breakaway posts. Posts other than 1 & 2 may be either standard wood posts or steel posts, at the option of the Contractor. If standard wood posts are used, one post shall be located midway between and in lieu of posts 4 & 5. The offset (Y) for this post shall be 300 mm (12 inches).

A two-piece assembly may be substituted for the one piece nose shown above.

The bearing plate K shall be held in position by (2) two eightpenny nails driven into the post and bent over the top of the plate.

All slope ratios are expressed as units of vertical displacement to units of horizontal displacement (V:H).

All dimensions are in millimeters (inches) unless otherwise shown.

**DETAIL INCLUDED
FOR REPAIR ONLY**