

**SHOULDER WIDENING TRANSITION
FOR FLARED TERMINAL**

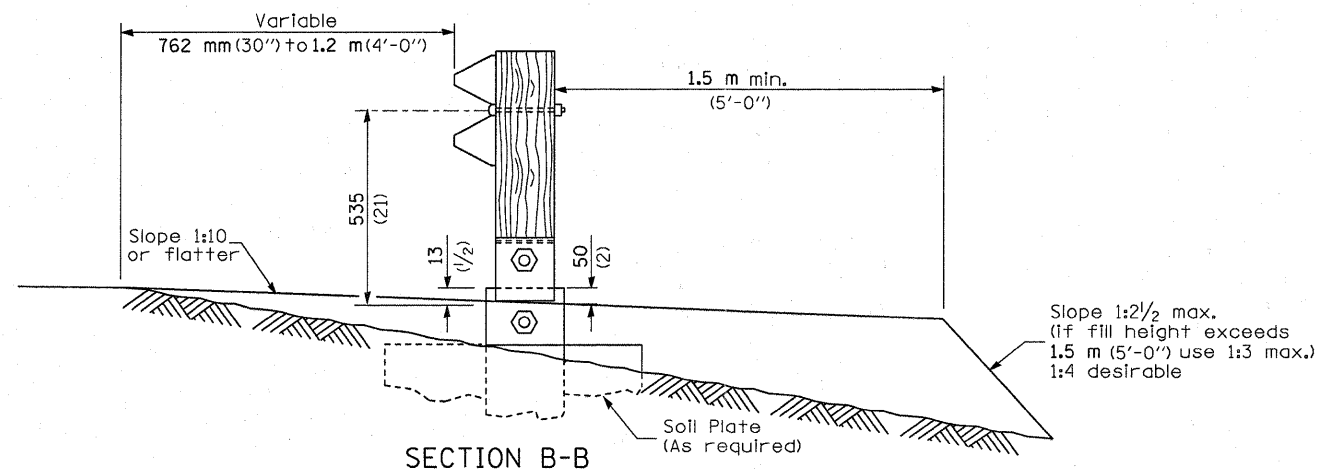

SECTION B-B

(End section omitted for clarity.)

• D-3 HIGHWAY DAMAGE REPAIR 2011

FILE NAME =	USER NAME = quigleyml	DESIGNED -	REVISED -	STATE OF ILLINOIS DEPARTMENT OF TRANSPORTATION	PRE-MGS EFFECTIVE 4-1-06 SHOULDER WIDENING FOR TYPE 1 (SPECIAL) GUARDRAIL TERMINALS STANDARD 630301-03				F.A. RTE.	SECTION	COUNTY	TOTAL SHEETS	SHEET NO.
c:\pw_work\pwsdot\quigleyml\d0258015\0366829-sht-DETAILS.dgn		DRAWN -	REVISED -		SCALE:	SHEET NO.	OF SHEETS	STA.	TO STA.	VAR.	VAR.	35	22
		CHECKED -	REVISED -		(Sheet 2 of 2)				CONTRACT NO. 66B29				
		DATE -	REVISED -		FED. ROAD DIST. NO. ILLINOIS FED. AID PROJECT								