

**GENERAL NOTES**

THIS DETAIL SHALL BE USED WHERE, AT ANY TIME, ANY VEHICLE, EQUIPMENT, WORKERS, OR THEIR ACTIVITIES WILL ENCR OACH ON ONE LANE OF A 2L, 2W HIGHWAY OR BRIDGE. TRAFFIC SIGNALS SHALL BE REQUIRED. THIS DETAIL SHALL BE USED IN CONJUNCTION WITH TRAFFIC CONTROL AND PROTECTION STANDARD 701321.

WHEN TRAFFIC SIGNALS ARE NOT IN OPERATION, FLAGGERS SHALL BE USED AND TRAFFIC CONTROL SHALL CONFORM TO TRAFFIC CONTROL AND PROTECTION STANDARDS 701201 OR 701206.

BIDIRECTIONAL LIGHTS SHALL BE USED AT NIGHT ALONG THE CENTERLINE WHERE THE WORK AREA IS SEPARATED FROM THE TRAVEL LANE USING DRUMS. MONO DIRECTIONAL LIGHTS SHALL BE USED AT NIGHT ON ALL OTHER DRUMS.

EXISTING OR TEMPORARY PAVEMENT MARKING SHALL BE ON BOTH SIDES OF THE OPEN LANE FROM STOP BAR TO STOP BAR. REQUIRED TEMPORARY PAVEMENT MARKING SHALL NOT BE PAID FOR SEPARATELY BUT SHALL BE INCLUDED IN THE COST OF THE TRAFFIC CONTROL AND PROTECTION, STANDARD 701321.

RELOCATION OF TRAFFIC CONTROL DEVICES FOR STAGING SHALL NOT BE PAID FOR SEPARATELY BUT SHALL BE INCLUDED IN THE COST OF TRAFFIC CONTROL AND PROTECTION, STANDARD 701316.

**SYMBOLS**

- WORK AREA
- SIGN
- TYPE III BARRICADE WITH STEADY BURNING LIGHT
- DRUM WITH STEADY BURNING LIGHT
- TRAFFIC SIGNAL WITH BACKPLATE
- DOUBLE VERTICAL PANEL
- MICROWAVE DETECTOR
- IMPACT ATTENUATOR
- TEMPORARY CONCRETE BARRIER
- AIR MONITORS

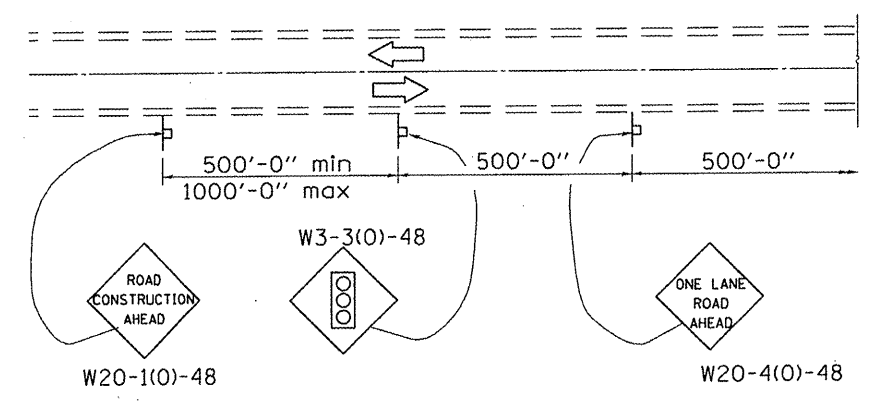

**BILL OF MATERIAL**

ITEM	UNIT	TOTAL
RELOCATE TEMPORARY CONCRETE BARRIER	FOOT	402