

STA. 202+91 TO STA. 238+00
 STA. 242+50 TO STA. 300+00
 STA. 304+00 TO STA. 317+90.25
 STA. 328+98 TO STA. 368+96
 STA. 380+12 TO STA. 408+00
 STA. 424+80 TO STA. 431+37.50
 STA. 434+10 TO STA. 446+37.50
 STA. 449+62.50 TO STA. 531+00
 STA. 547+62.50 TO STA. 558+50

STA. 558+50 TO STA. 588+70 (OMISSION)
 STA. EQ. 563+35.31 BK = 563+35.80 AH
 STA. 588+70 TO STA. 590+37.50
 STA. 601+25 TO STA. 607+71.98
 STA. EQ. 607+71.98 BK = 607+92.41AH
 STA. 607+92.41 TO STA. 617+12.19
 STA. EQ. 617+12.19 BK = 616+60.02 AH
 STA. 616+60.02 TO STA. 623+14

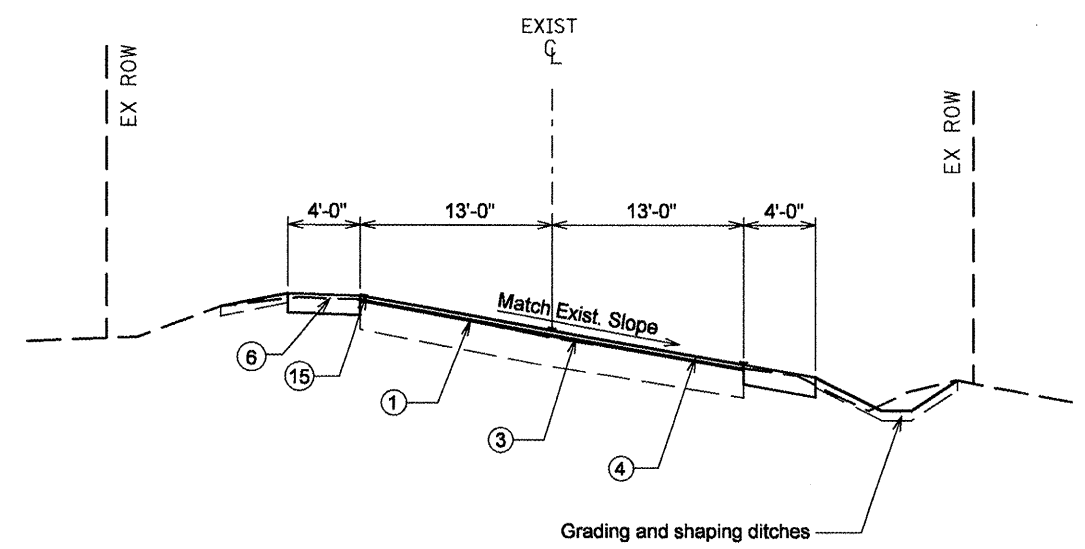

STA. 317+90.25 TO STA. 327+48.13
 STA. EQ. 327+48.13 BK = 327+30.04 AH
 STA. 327+30.04 TO STA. 328+98.00
 STA. 368+96.00 TO STA. 380+12.00

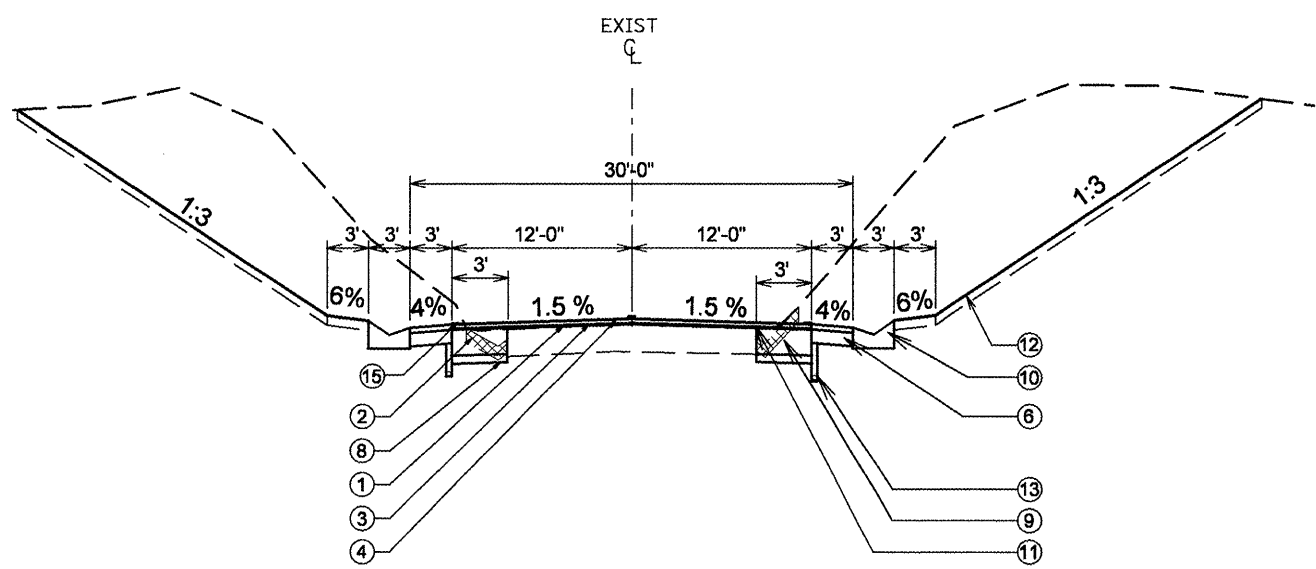

STA. 410+75 TO STA. 415+50

LEGEND

- 1 - H.M.A. Surface Removal, 1½"
- 2 - Gutter Removal (Special)
- 3 - Poly. Leveling Binder (M.M.), ¾"
- 4 - H.M.A. Surface Course, 1½"
- 5 - Aggregate Shoulders, Type B (Wedge)
- 6 - H.M.A. Shoulders 8"
- 7 - Aggregate Shoulders Type B, 6"
- 8 - Subbase Granular Material Type B, 4"
- 9 - H.M.A. Binder Course 10"
- 10 - Concrete Gutter Type A (Special)
- 11 - Strip Reflective Crack Control Treatment
- 12 - Topsoil Furnished and Place, 4"
- 13 - Pipe Under Drain, 4"
- 14 - Proposed Retaining Wall
- 15 - Proposed Pavement Marking
- 16 - Pipe underdrain for Structures, 4"

FILE NAME = typical sections.dgn	USER NAME = mendezpj	DESIGNED -	REVISED -
		DRAWN -	REVISED -
		CHECKED -	REVISED -
		DATE -	REVISED -

STATE OF ILLINOIS
DEPARTMENT OF TRANSPORTATION

TYPICAL SECTIONS			
SCALE:	SHEET NO.	OF SHEETS	STA. TO STA.

F.A.P. RTE. 685	SECTION ..	COUNTY ..	TOTAL SHEETS 329	SHEET NO. 15
CONTRACT NO. 68599				
ILLINOIS FED. AID PROJECT				