

GENERAL NOTES

Length and number of steel pipes shall be determined by the Contractor except as shown. All steel pipe shall be standard weight (Sch. 40) unless otherwise noted.

All components of the Steel Pipe Grate System shall be galvanized according to the requirements of AASHTO M 111 or M 232 as applicable.

Fabrication of the Steel Pipe Grate System shall conform to the requirements in Section 505 of the Standard Specifications unless noted otherwise.

Structural steel shapes and plates shall conform to the requirements of Article 1006.04 of the Standard Specifications. Steel pipes shall conform to the requirements of ASTM A 53 (Type E or S), Grade B.

Anchor rods shall conform to the requirements of ASTM F1554, Grade 105. Anchor rods shall be drilled and epoxy grouted according to the requirements of Section 584 of the Standard Specifications. The chemical adhesive system shall be capable of achieving a minimum proof load of 5000 pounds and an ultimate shear capacity of 8000 pounds per anchor.

Bolts and thru bolts shall conform to the requirements of Article 1006.08 of the Standard Specifications except threaded rods conforming to the requirements of ASTM F1554, Grade 105 may be used for the thru bolts.

The minimum edge distance from the center of a hole to the free edge of a structural shape or plate shall be $1\frac{1}{2}$ " unless noted otherwise.

Bolts and anchor rods shall be snug tightened by a few impacts of an impact wrench or the full force of a worker using an ordinary spud wrench.

All cost associated with fabricating, furnishing, and installing the Steel Pipe Grate System shall be included in the contract unit price for Grating for Drop Box.

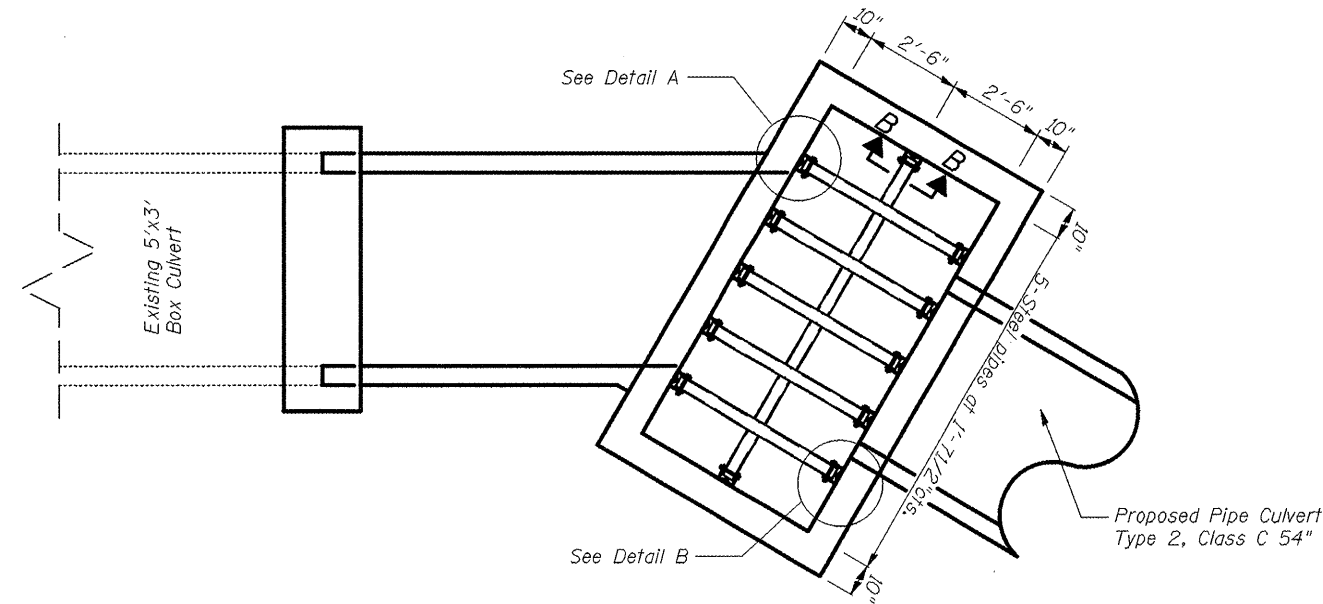

PLAN VIEW

NOT TO SCALE

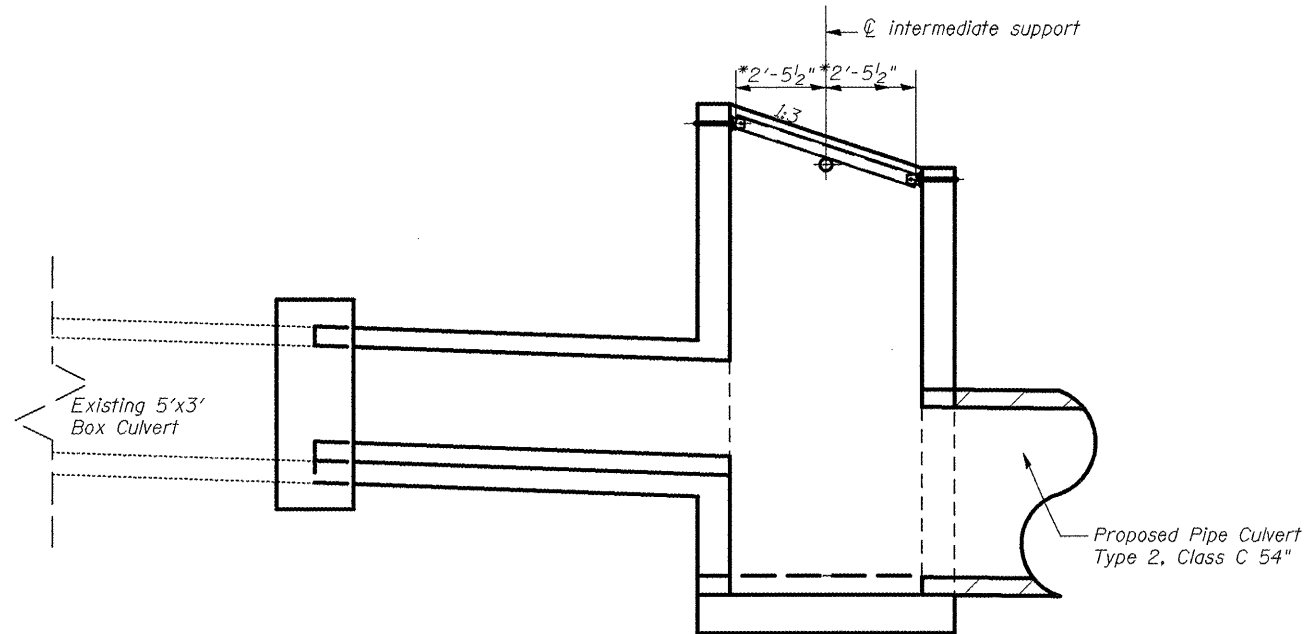

LONGITUDINAL SECTION

NOT TO SCALE

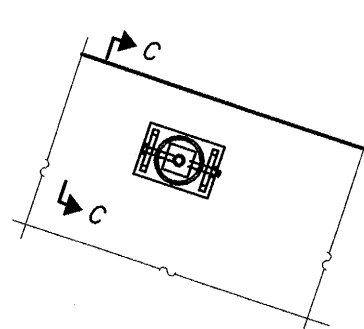

SECTION B-B

(See Detail A for dimensions and details not shown.)

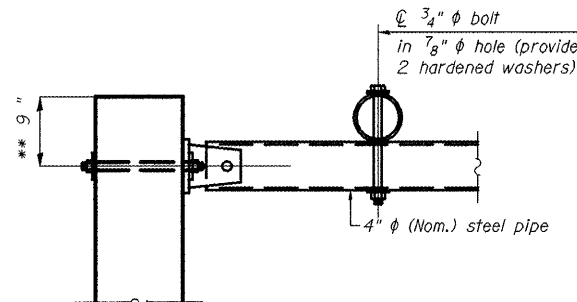

SECTION C-C

** Measured perpendicular to top of culvert wall. In addition, formed hole shall be located a minimum of 6" measured horizontally from any vertical joints necessary for construction of the culvert end section.

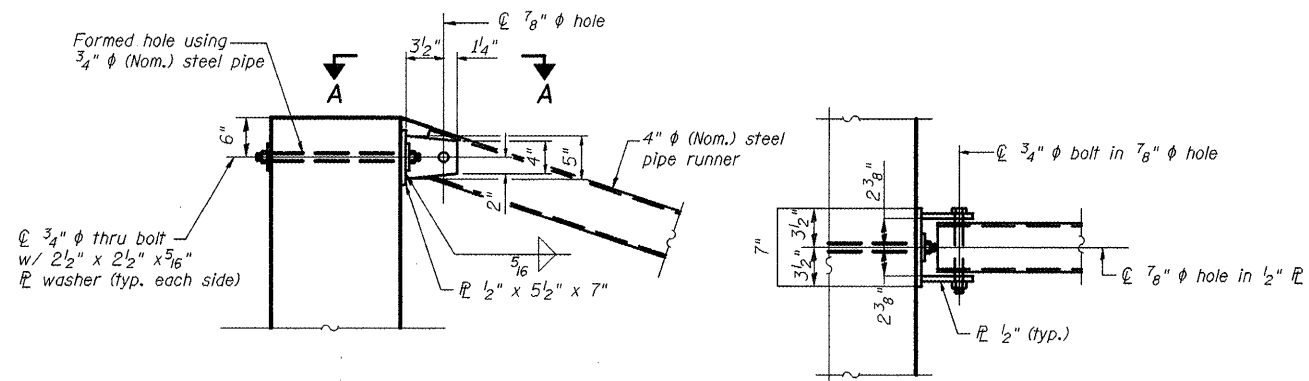

DETAIL A

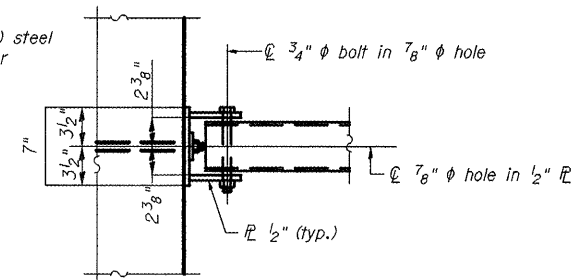

SECTION A-A

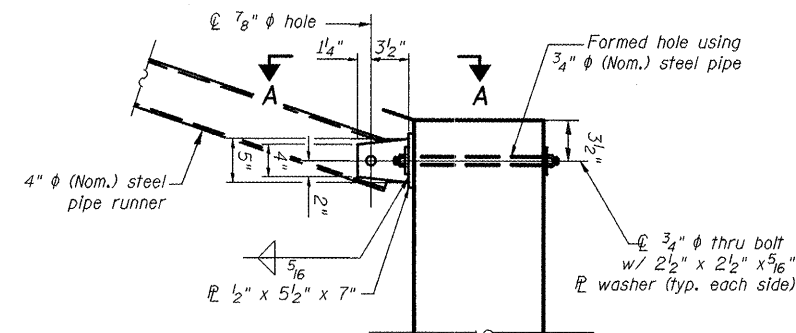

DETAIL B

FILE NAME = sht-details.dgn	USER NAME = mendezpj	DESIGNED -	REVISED -
		DRAWN -	REVISED -
		CHECKED -	REVISED -
		DATE -	REVISED -

**STATE OF ILLINOIS
DEPARTMENT OF TRANSPORTATION**

**GRADED INLET, SPECIAL DETAIL
RT. STA. 534 + 29.26**

F.A.P. RTE. 685	SECTION ..	COUNTY ..	TOTAL SHEETS 329	SHEET NO. 150
CONTRACT NO. 68599				

SCALE: SHEET NO. OF SHEETS STA. TO STA.