

**ELEVATION**  
(Looking North)

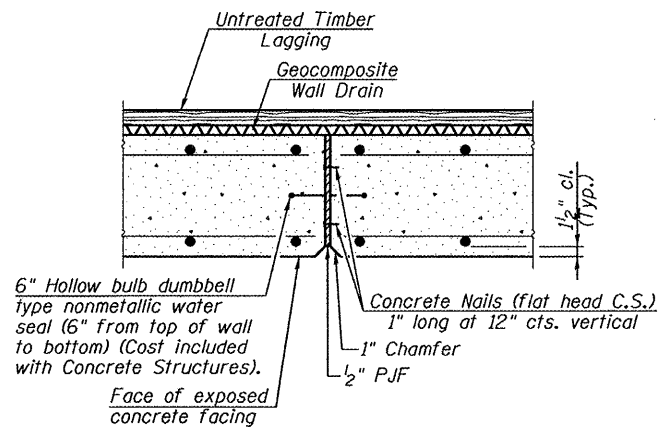

**WALL EXPANSION JOINT**

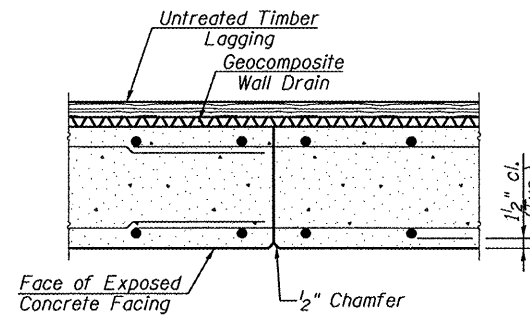

**WALL CONSTRUCTION JOINT**

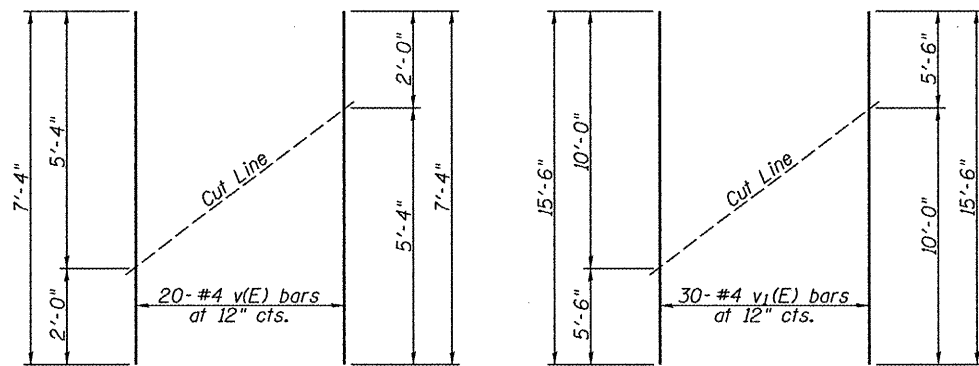

**BAR v(E)**

**BAR v<sub>1</sub>(E)**

**FIELD CUTTING DIAGRAMS**

Order v(E) & v<sub>1</sub>(E) bars full length.  
Cut as shown and use remainder of bars  
in opposite face.

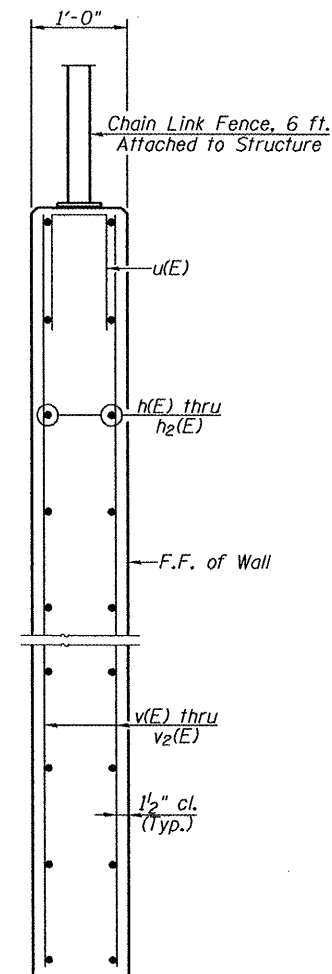

**SECTION THRU CONCRETE FACING**  
(Looking East)

**MIN. BAR LAPS**

#4 bar = 2'-0"  
#5 bar = 3'-3"

Notes: Bars indicated thus 30 x 2-#4 etc.  
indicates 30 lines of bars with 2 lengths  
per line.  
See Sheet 9 of 12 for Bill of Material and  
u(E) bar details.  
See Sheet 10 of 12 for Fence Details  
and Post Spacing.

FILE NAME =	USER NAME =	DESIGNED -	REVISED -	<p>Allen Henderson &amp; Associates, Inc. Civil and Structural Engineers Springfield, IL 62703 Phone: (217)544-8033 IL Design Firm No. 184-001907</p>	CONCRETE FACING SECTION	F.A.P. RTE.	SECTION	COUNTY	TOTAL SHEETS	SHEET NO.
		CHECKED -	REVISED -		STRUCTURE NO. 029-8505	685	(37,38) RS-3, 39RS-5	FULTON	329	161
		DRAWN -	REVISED -		SHEET NO. 5 OF 12 SHEETS	CONTRACT NO. 68599				
		CHECKED -	REVISED -		ILLINOIS FED. AID PROJECT					