

ELEVATION
(Looking North)

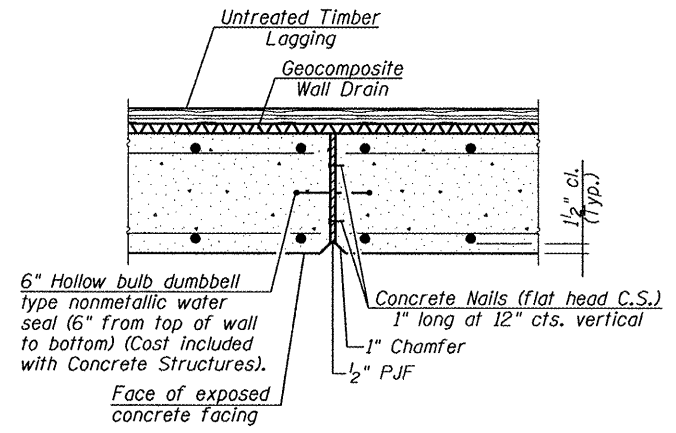

WALL EXPANSION JOINT

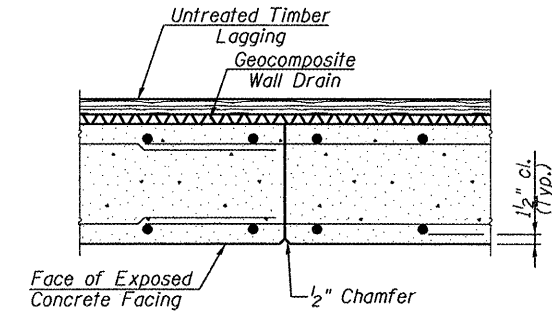

WALL CONSTRUCTION JOINT

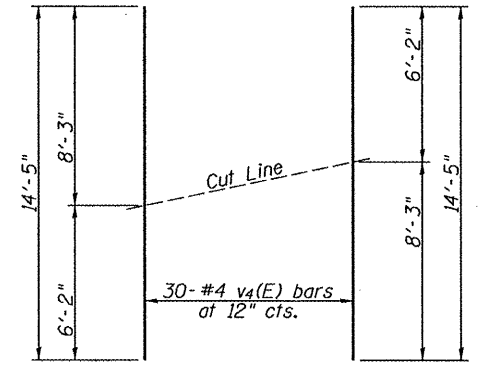

BAR v₄(E)

FIELD CUTTING DIAGRAM
Order v₄(E) bars full length. Cut as shown and use remainder of bars in opposite face.

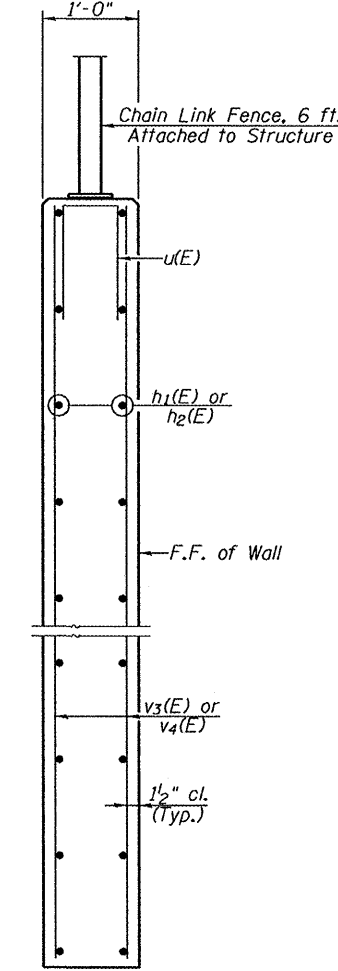

SECTION THRU CONCRETE FACING
(Looking East)

MIN. BAR LAPS
#4 bar = 2'-0"
#5 bar = 3'-3"

Notes: Bars indicated thus 30 x 2- #4 etc. indicates 30 lines of bars with 2 lengths per line.
See Sheet 9 of 12 for Bill of Material and u(E) bar details.
See Sheet 10 of 12 for Fence Details and Post Spacing.

FILE NAME =	USER NAME =	DESIGNED -	REVISED -	 Allen Henderson & Associates, Inc. Civil and Structural Engineers Springfield, IL. 62703 Phone: (217)544-8033 IL Design Firm No. 184-001907	CONCRETE FACING SECTION		F.A.P. RTE.	SECTION	COUNTY	TOTAL SHEETS	SHEET NO.
PLOT SCALE =	CHECKED -	REVISED -	REVISED -		685	(37,38) RS-3, 39RS-5	FULTON	329	164		
PLOT DATE =	DRAWN -	REVISED -	REVISED -		CONTRACT NO. 68599			ILLINOIS FED. AID PROJECT			
	CHECKED -	REVISED -	REVISED -		SHEET NO. 8 OF 12 SHEETS						