

TYPE A

1.905 m (6'-3") Typical post spacing

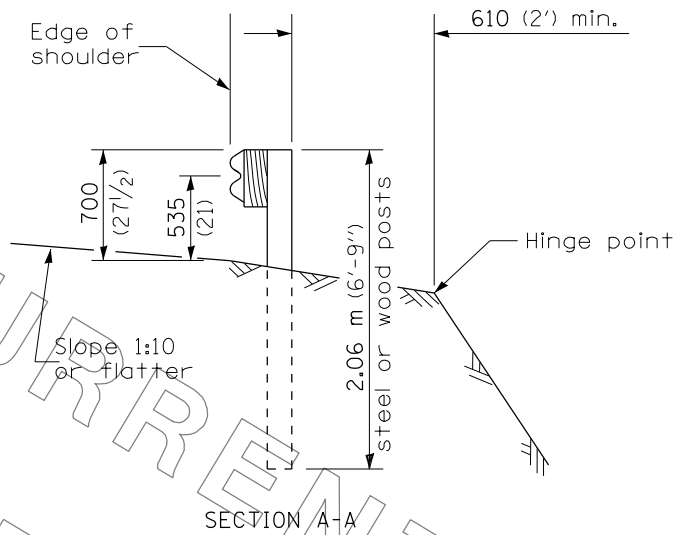

SECTION A-A

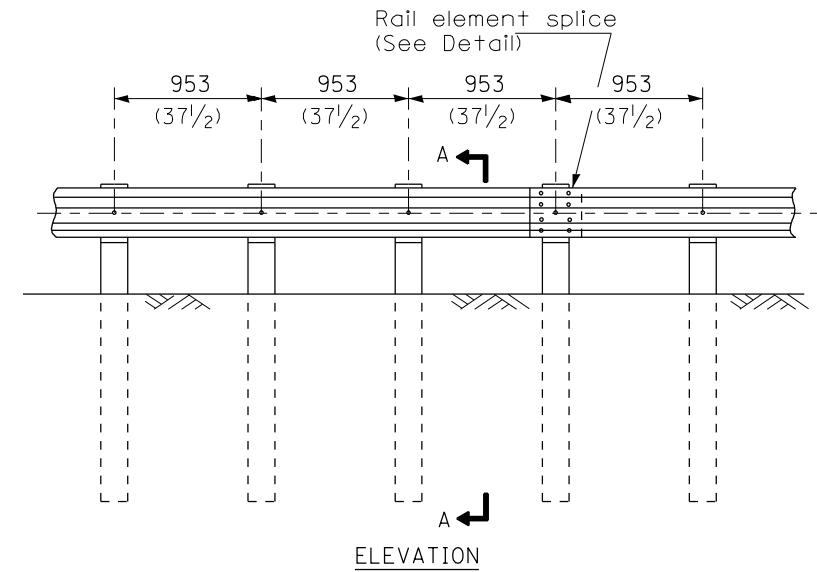

TYPE B

953 (37 1/2) Closed post spacing

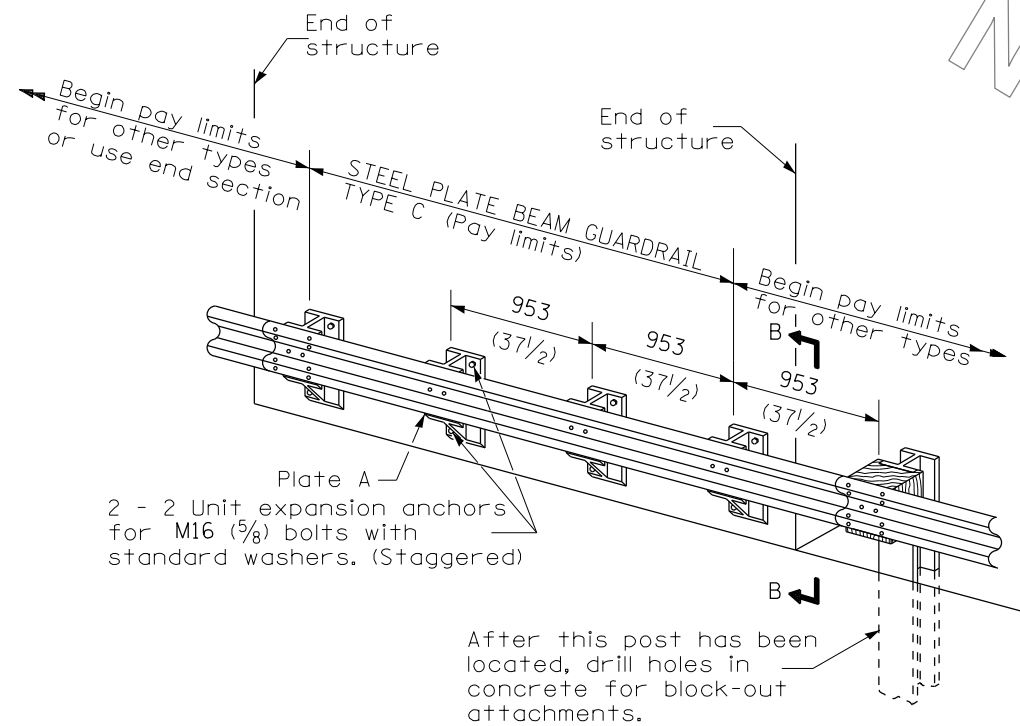

TYPE C

953 (37 1/2) Block-out spacing

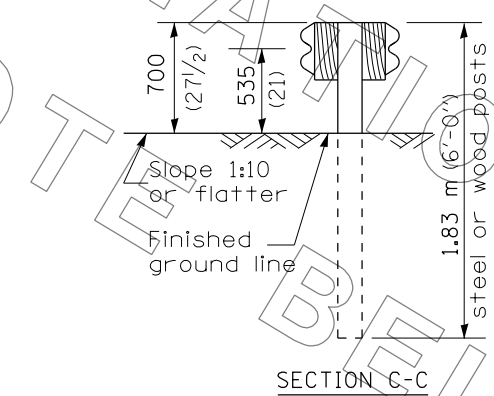

SECTION C-C

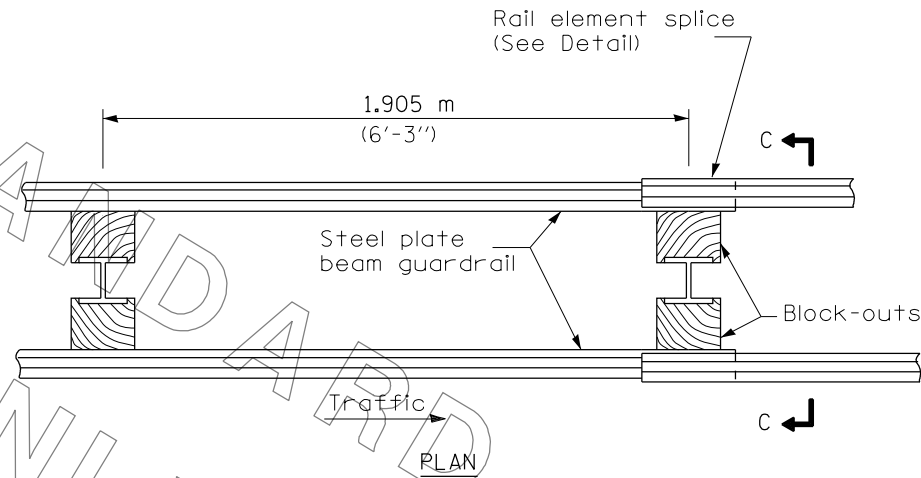

TYPE D

Double steel plate beam guardrail
1.905 m (6'-3") typical post spacing

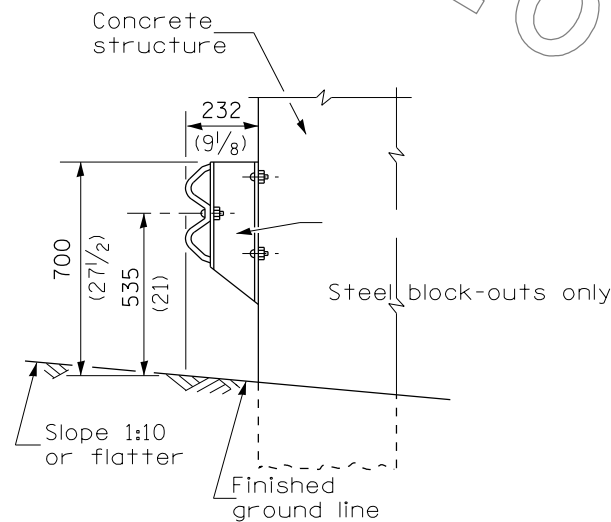

SECTION B-B

NOTE:

THIS DETAIL SHALL BE USED FOR GUARDRAIL REPAIRS WHERE NEW STEEL PLATE BEAM GUARDRAIL AND TERMINAL SECTIONS WILL BE TIED INTO EXISTING STEEL PLATE BEAM GUARDRAIL AS WELL AS FOR REMOVING AND RE-ERECTING THE RAIL ELEMENT.

GENERAL NOTES

All slope ratios are expressed as units of vertical displacement to units of horizontal displacement (V:H).

All dimensions are in millimeters (inches) unless otherwise shown.

The existing steel posts may be drilled to match the bolt pattern shown herein for the wood block-out, or a new steel post shall be provided.

This detail is applicable to the guardrail system used prior to January 1, 2007. For details on the Midwest Guardrail System, see Standard 630001.

FILE NAME =	USER NAME = Sparksgw	DESIGNED -	REVISED -	STATE OF ILLINOIS DEPARTMENT OF TRANSPORTATION	D6 GUARDRAIL END REPL GUARDRAIL MODIFICATION SHEETS			F.A.P. RT.	SECTION	COUNTY	TOTAL SHEETS	SHEET NO.	
c:\pwork\work\pwork\sparksgw\0247448\0672E16-sht-guardrail-modification.dgn		DRAWN -	REVISED -		SCALE:	SHEET NO.	OF SHEETS	STA.	TO STA.	ILLINOIS FED. AID PROJECT	CONTRACT NO. 72E16	17	14
		CHECKED -	REVISED -										
		DATE -	REVISED -										