

STATE OF ILLINOIS  
DEPARTMENT OF TRANSPORTATION

Notes:

Remove unstable material along bottom of undermined area prior to bag placement and filling with grout.

Stack grout bags along face of pier in front of undermined area. Bags stacked in successive rows and tiers shall be staggered.

Once vent/fill pipes have been installed and bags are filled, pump grout into the undermined area until material appears in the top of adjacent vent pipes. Cut or remove the vent/fill pipes and flush with the top of the bags after pumping operation is complete.

Adequate venting of water to be displaced in the undermined area is important. The water must be able to escape when displaced by grout pumped into the cavity. A max 4ft spacing of vent/fill pipes is recommended.

Keep nozzle buried in the grout during pumping to reduce the amount of mixing of the grout and water to be displaced.

All bags shall be 1 ft max thick, 3 ft max wide and 4 ft max long.

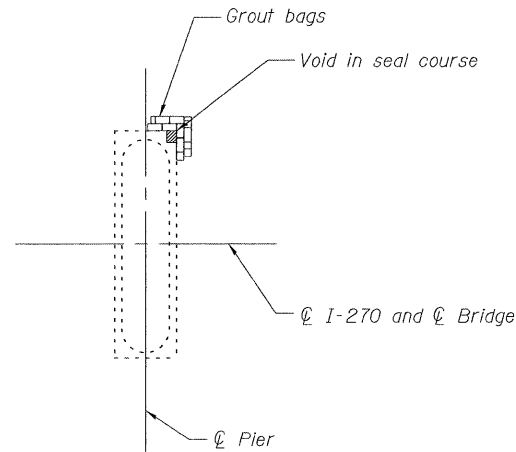

PLAN AT PIER 18

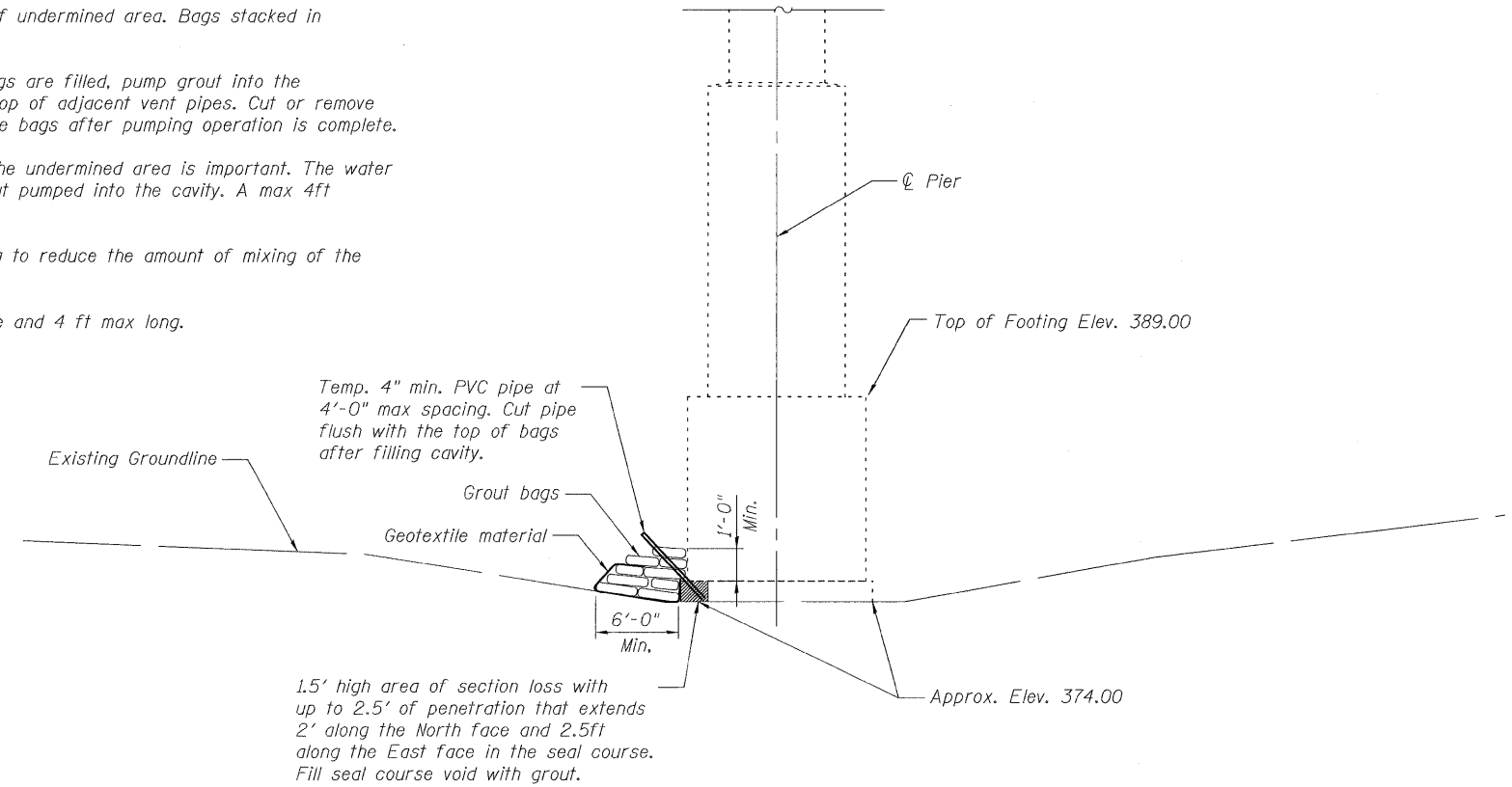

SECTION

North Face shown, South Face similar with the exception of the void and grout bags.

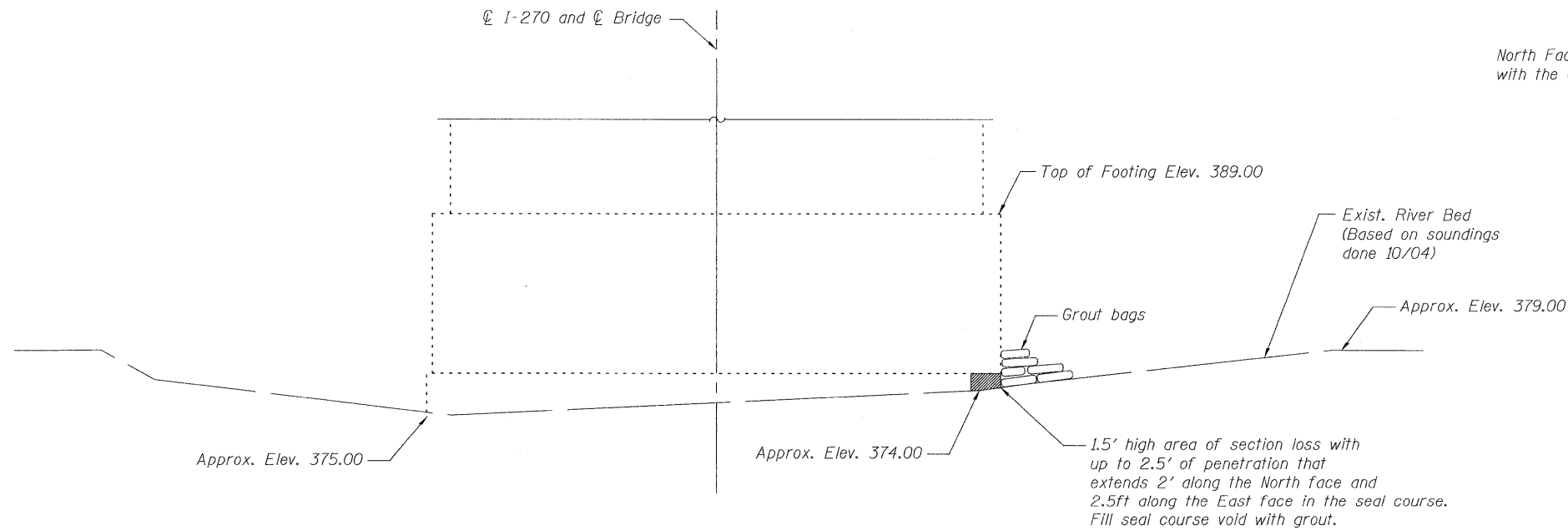

ELEVATION

East Face shown, West Face similar with the exception of the void and grout bags.

Notes:

Area of section loss based on Under Water Inspection. See sht 36 of 36.

Plan dimensions and details relative to existing structure have been taken from existing plans and are subject to minimal construction variations. It shall be the Contractor's responsibility to verify such dimensions and details in the field and make necessary approved adjustments prior to construction or ordering of materials. Such variations shall not be cause for additional compensation for a change in the scope of the work, however, the Contractor will be paid for the quantity actually furnished at the unit price bid for the work.

The Contractor shall submit a complete repair plan 3 weeks prior to starting this work for approval by the Engineer.

SCOUR PROTECTION PIER 18  
STRUCTURE NO. 060-0035

**BILL OF MATERIAL**

Item	Unit	Quantity
Substructure Repairs (Grout Bags)	L SUM	1

SHEET NO. 35	F.A.I. RTE.	SECTION	COUNTY	TOTAL SHEETS	SHEET NO.
	270	60B-I-8	MADISON	49	48
36 SHEETS	CONTRACT NO. 76A92				
FED. ROAD DIST. NO. 8 ILLINOIS FED. AID PROJECT					

DESIGNED	TMB
CHECKED	TSB
DRAWN	JGC / TMB
CHECKED	TSB

