

EAST CURB LINE

Location	Station	Offset	Theoretical Grade Elevations
Bk. S. Abutment	713+19.00	-16.42	389.77
A	713+29.00	-16.42	389.77
B	713+39.00	-16.42	389.77
End of S. Approach Slab	713+49.00	-16.42	389.77

EAST EDGE OF PAVEMENT

Location	Station	Offset	Theoretical Grade Elevations
Bk. S. Abutment	713+19.00	-12.00	389.86
A	713+29.00	-12.00	389.86
B	713+39.00	-12.00	389.86
End of S. Approach Slab	713+49.00	-12.00	389.86

☉ STRUCTURE & STAGE CONSTRUCTION LINE

Location	Station	Offset	Theoretical Grade Elevations
Bk. S. Abutment	713+19.00	0.00	390.05
A	713+29.00	0.00	390.05
B	713+39.00	0.00	390.05
End of S. Approach Slab	713+49.00	0.00	390.05

WEST EDGE OF PAVEMENT

Location	Station	Offset	Theoretical Grade Elevations
Bk. S. Abutment	713+19.00	12.00	389.86
A	713+29.00	12.00	389.86
B	713+39.00	12.00	389.86
End of S. Approach Slab	713+49.00	12.00	389.86

WEST CURB LINE

Location	Station	Offset	Theoretical Grade Elevations
Bk. S. Abutment	713+19.00	16.42	389.77
A	713+29.00	16.42	389.77
B	713+39.00	16.42	389.77
End of S. Approach Slab	713+49.00	16.42	389.77

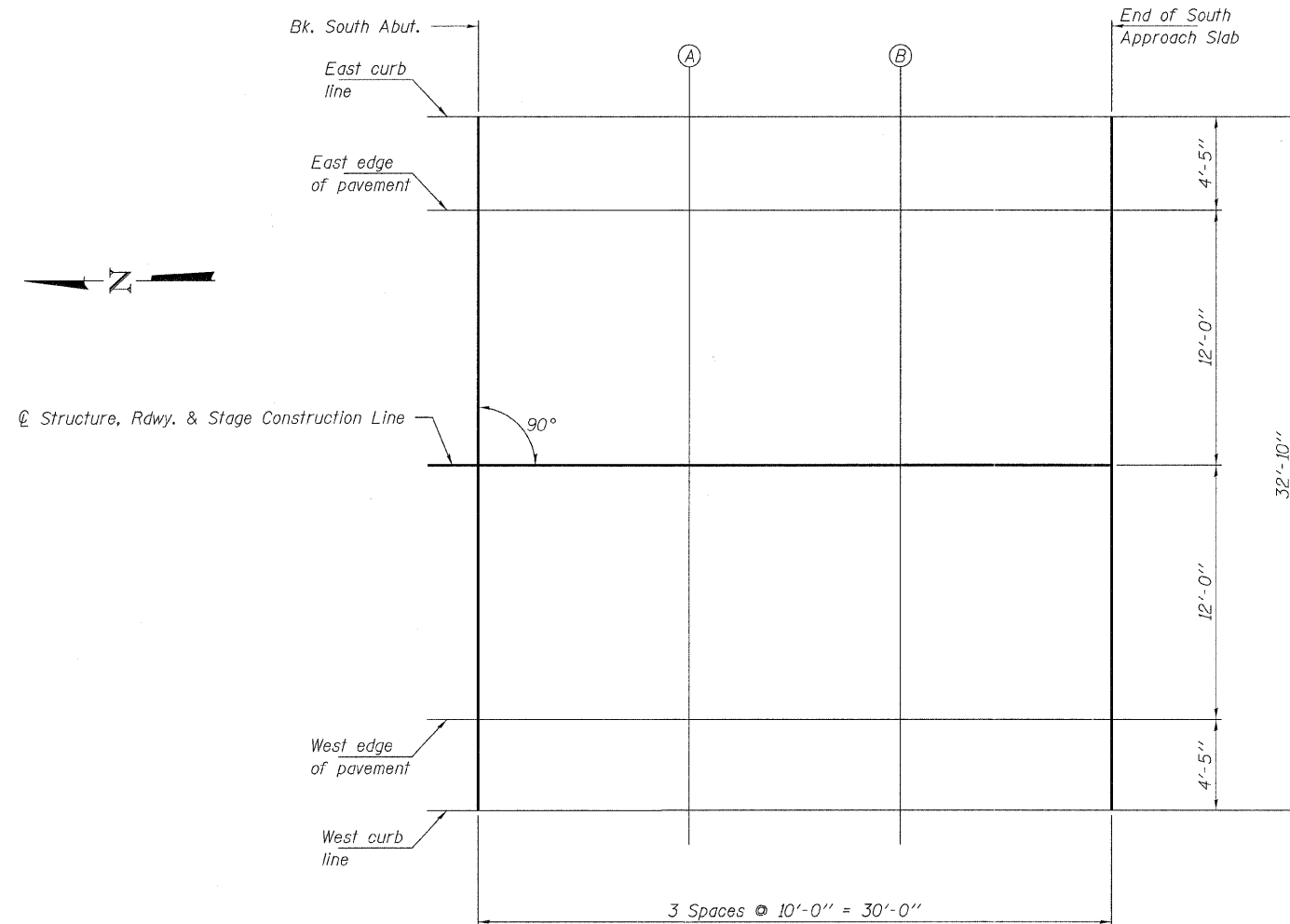

SOUTH APPROACH SLAB - PLAN