

ELEVATION
Showing Rail Post Spaces
See sheet 6 of 9 for Railing Details.

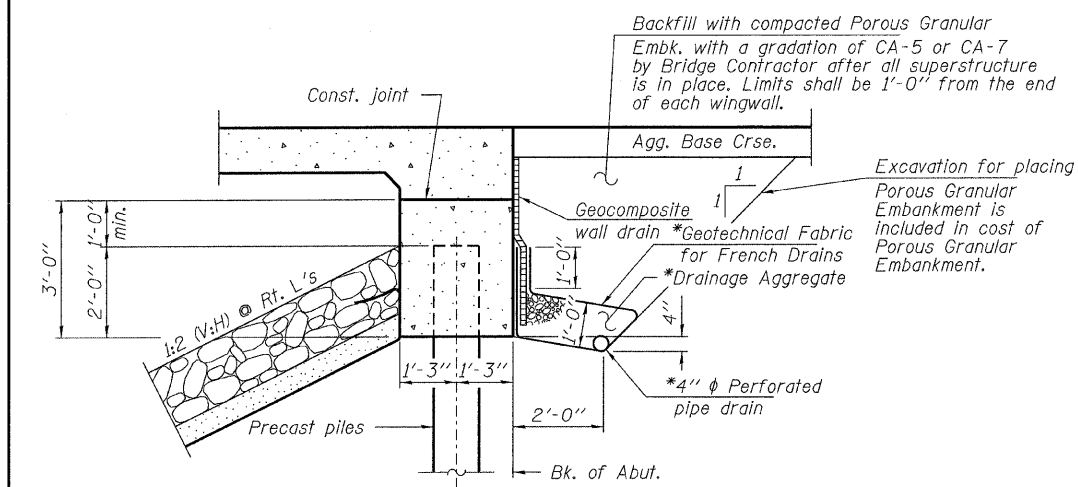

SECTION A-A
(Horiz. dim. @ Rt. L's)

*Included in the cost of Pipe Underdrains for Structures, 4".

Note:
All drainage system components shall extend to 2'-0" from the end of each wingwall except an outlet pipe shall extend until intersecting with the side slopes. The pipes shall drain into concrete headwalls. (See Article 601.05 of the Standard Specifications and Highway Standard 601101).

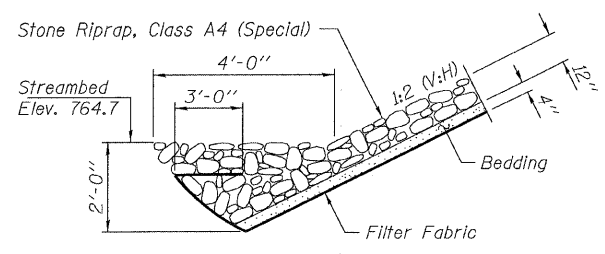

SECTION B-B

Note: See Special Provisions for Stone Riprap, Class A4 (Special).

GENERAL NOTES

Layout of the slope protection system may be varied to suit ground conditions in the field as directed by the Engineer.
The Contractor shall drive test piles to 110% of the nominal required bearing specified in production locations at West Abutment and Pier 2 or approved by the Engineer before ordering the remainder of piles.
Reinforcement bars shall conform to the requirements of ASTM A 706 Gr 60. See Special Provisions.
Excavation required to construct the Abutments and Piers shall be included in the cost of Concrete Structures. No additional compensation will be allowed for Structure Excavation.
All proposed construction activities shall be in accordance with Nationwide Permit number 14 of the Department of the Army authorized under Section 404 of the Clean Water Act. The IEPA has issued Section 401 Water Quality Certification for this activity. See Special Provisions for conditions.
The top surface of the deck shall be screeded with a straight edge and then finished with a wooden hand float. Further finishing shall be delayed until the water sheen appears, but not to the point of rendering further manipulation ineffective. The surface then shall be roughened with a suitable stiff-bristled broom or wire brush drawn in transverse direction removing any laitance present and breaking up the water sheen. The corrugations formed shall be uniform in appearance and in no case more than 1/4" in depth.

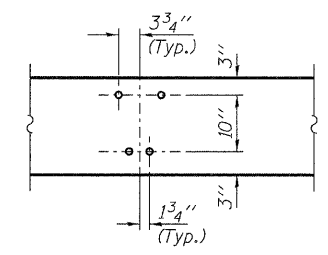

DETAIL A

TOTAL BILL OF MATERIAL

ITEM	UNIT	SUPER	SUB	TOTAL
Channel Excavation	Cu. Yd.			250
Porous Granular Embankment	Ton		89	89
Removal of Existing Structures	Each			1
Concrete Structures	Cu. Yd.		34.4	34.4
Concrete Superstructure	Cu. Yd.	79.3		79.3
Reinforcement Bars, Epoxy Coated	Pound		34,160	34,160
Steel Railing, Type S1	Foot	137		137
Furnishing Precast Concrete Piles, 14"	Foot		555	555
Driving Piles	Foot		555	555
Test Pile Precast Concrete	Each		2	2
Name Plates	Each		1	1
Geocomposite Wall Drain	Sq. Yd.			40
Stone Riprap, Class A4 (Special)	Ton			240
Pipe Underdrains for Structures, 4"	Foot			120

FILE NAME = 100353-shr-bridge.dgn	USER NAME =	DESIGNED - A.S.L.	REVISED -
HAMPTON, LENZINI AND RENWICK, INC.		CHECKED - S.W.M.	REVISED -
3045 STEVENSON DRIVE, SUITE 201 SPRINGFIELD, ILLINOIS 62781	PLOT SCALE =	DRAWN - D.T.M.	REVISED -
ILLINOIS PROFESSIONAL DESIGN FIRM LS / PE / SE CORP. 184-00069	PLOT DATE = 3/2/2011	CHECKED - S.W.M.	REVISED -

STATE OF ILLINOIS
McLEAN COUNTY HIGHWAY DEPARTMENT

GENERAL DETAILS
STRUCTURE NO. 057-3519
SHEET NO. 2 OF 9 SHEETS

T.R.	SECTION	COUNTY	TOTAL SHEETS	SHEET NO.
221A	10-07133-00-BR	McLEAN	19	12
SCHULTZ BRIDGE		CONTRACT NO. 91455		
		ILLINOIS FED. AID PROJECT BR05-0113034		