

ROUTE NO.	SECTION	COUNTY	TOTAL SHEETS	SHEET NO.
FAU 8390	04-00084-01-PV	EFFINGHAM	139	6
FED. ROAD DIST. NO. 7	ILLINOIS			

CONTRACT #95639

**PAVING LEGEND**

- ① HOT-MIX ASPHALT SURFACE COURSE, MIX "C", N70, 1 3/4"
- ② HOT-MIX ASPHALT BINDER COURSE, IL-25.0, N70, 1 3/4"
- ③ HOT-MIX ASPHALT BINDER COURSE, IL-25.0, N70, 1 3/4"
- ④ 10" SOIL CEMENT BASE COURSE, CONSIST OF 5" AGGREGATE BASE COURSE, TYPE A AND 5" OF SOIL ALL MIXED WITH 12% CEMENT (BY VOLUME)
- ⑤ HOT-MIX ASPHALT SURFACE COURSE, MIX "C", N70, 1 3/4"
- ⑥ AGGREGATE BASE COURSE, TYPE A, 8"

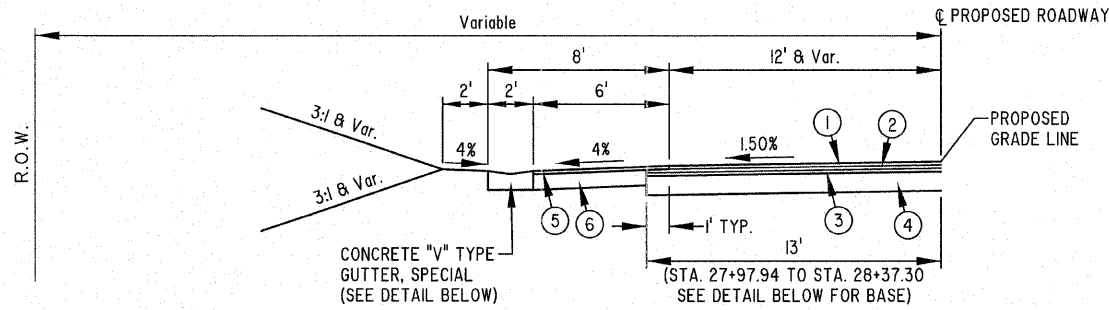

**TYPICAL SECTION - EVERGREEN AVENUE**  
LT STA. 27+79.94 TO STA. 32+35.30

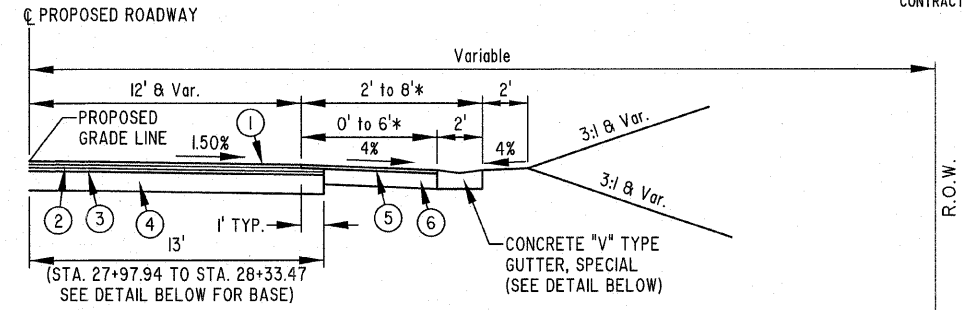

**TYPICAL SECTION - EVERGREEN AVENUE**  
RT STA. 27+79.94 TO STA. 28+33.47

\* STA. 28+08.49 TO STA. 28+33.47

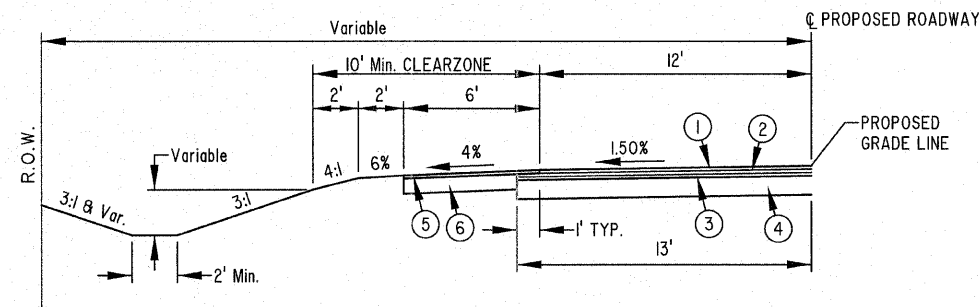

**TYPICAL SECTION - EVERGREEN AVENUE**  
LT STA. 32+35.30 TO STA. 32+63.87

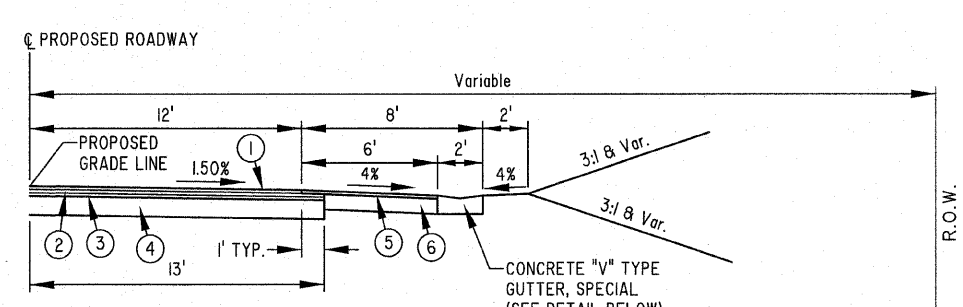

**TYPICAL SECTION - EVERGREEN AVENUE**  
RT STA. 28+33.47 TO STA. 32+63.87

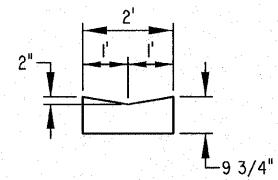

**"V" TYPE GUTTER, SPECIAL**

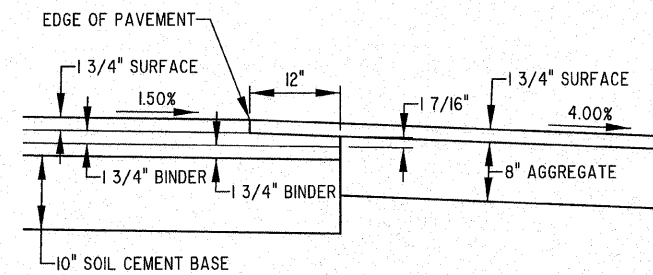

**THICKNESS TRANSITION - HOT-MIX BINDER**

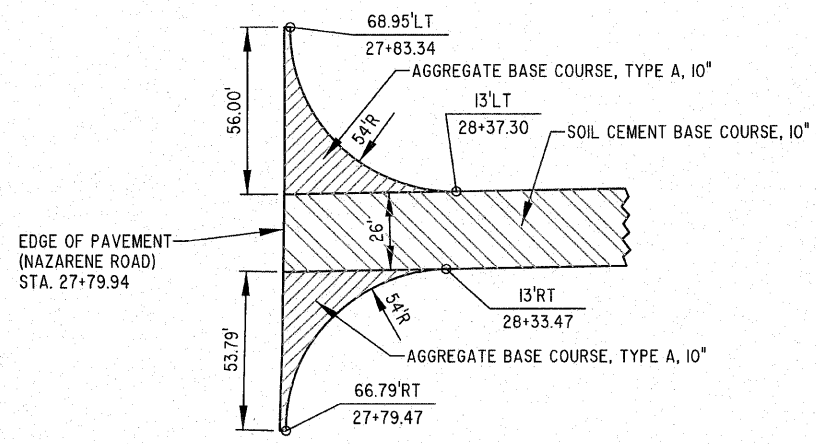

**NAZARENE ROAD AND EVERGREEN AVENUE INTERSECTION BASE DETAIL**

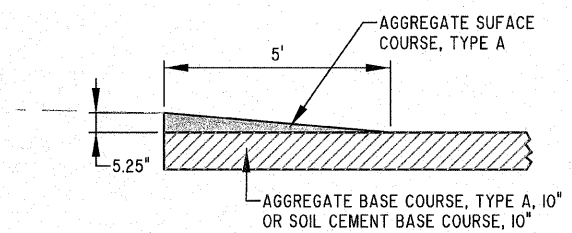

**NAZARENE ROAD AND EVERGREEN AVENUE TEMPORARY FILLET DETAIL**

PAVEMENT DESIGN - EVERGREEN AVENUE  
SECTION 04-00084-01-PV  
STA. 27+79.94 TO STA. 94+92.73  
WINPAS PAVEMENT ANALYSIS SOFTWARE  
CLASS II STREET: LOCAL ROAD (80,000 lb Trucks)

URBAN  
STRUCTURAL DESIGN PV=2966  
TRAFFIC (2021): SU=III  
MU=7  
TOTAL FLEXIBLE ESALS: 3,207,562  
REQUIRED STRUCTURAL NUMBER: 5.47  
DESIGNED STRUCTURAL NUMBER: 5.67

STA. 27+79.94 TO STA. 32+63.87

**MILANO & GRUNLOH ENGINEERS, LLC**  
84 WEST WASHINGTON  
P.O. BOX 897  
EFFINGHAM, ILLINOIS 62401  
PHONE: (217) 347-7282  
(800) 677-2714  
FAX #: (217) 342-3433  
File name: S:\DWG\05\05227\dwg\Typical.dwg  
Plot date: 02/08/11 at 16:00

TYPICAL SECTIONS  
EVERGREEN AVENUE  
COUNTY OF EFFINGHAM, ILLINOIS