

STATE OF ILLINOIS  
DEPARTMENT OF TRANSPORTATION

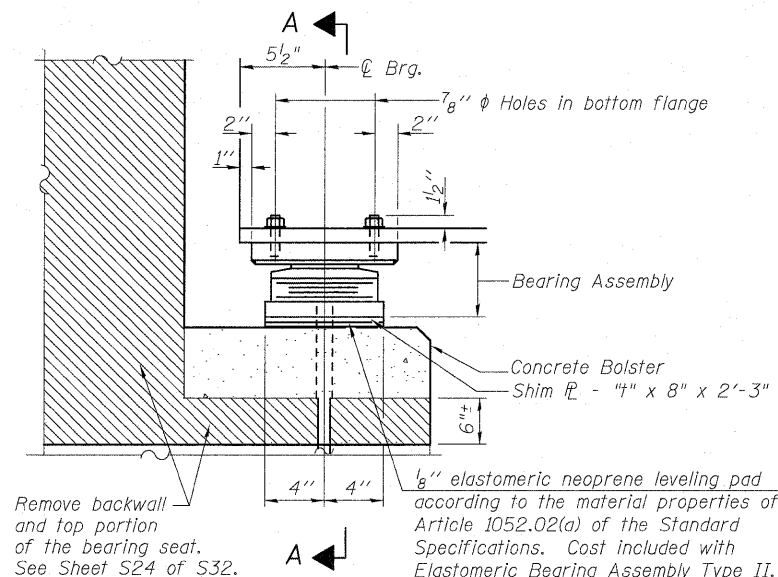

ELEVATION AT WEST ABUT.

TYPE II ELASTOMERIC EXP. BRG.

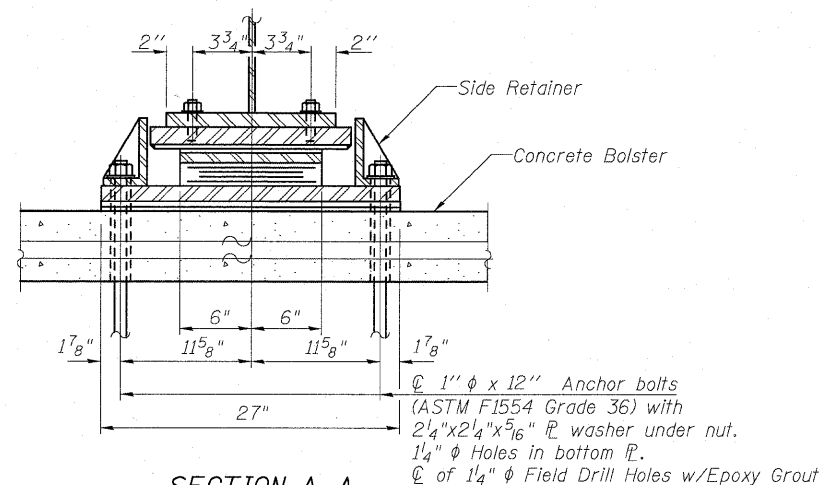

SECTION A-A

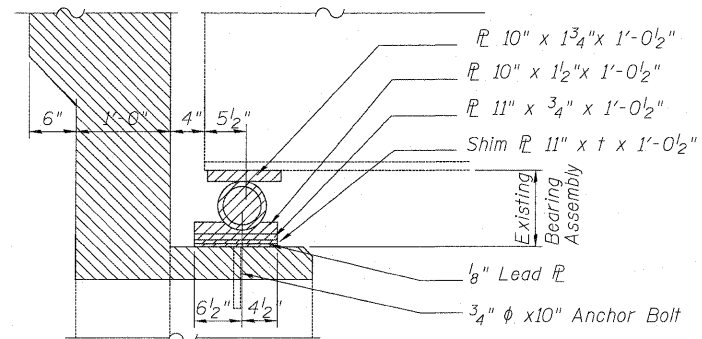

EXISTING WEST ABUTMENT BEARING TO BE REMOVED

Remove and replace all existing bearing assembly at the West and East Abutments with Elastomeric Bearing Assembly

NOTES - JACKING AND CRIBBING

- The contractor shall submit for approval by the engineer, plans for jacking and cribbing prior to commencing any work on the bearing.
- Jacking and removing existing bearing, including top and bottom plates and the lead plates, shall be done after deck removal is completed and before the new deck is poured.
- All Stage I or Stage II beams shall be lifted simultaneously in stages.
- Top plates welded to the bottom flange of beams shall be removed using the air-arc method and grind smooth all weld material remaining on the bottom flange. Cost included with Jack and Remove Existing Bearing.
- The new bearings shall be in place and the jacks shall be lowered before the new deck is poured.
- The cost of removing existing bearings is included in the cost of Jacking and Cribbing.

Notes:

Anchor bolts shall be ASTM F1554 all-thread (or an Engineer-approved alternate material) of the grade(s) and diameter(s) specified. ASTM A307 Grade C anchor bolts may be used in lieu of ASTM F1554 Grade 36 (Fy=36ksi). The corresponding specified grade of AASHTO M314 anchor bolts may be used in lieu of ASTM F1554.

Anchor bolts for Type II bearings shall be placed in holes drilled in the concrete through holes in the bottom bearing plate after members are in place. Side retainers shall be placed after bolts are installed.

Drilled and set anchor bolts shall be installed according to Article 521.06 of the Standard Specifications.

Side retainers and other steel members required for the bearing assembly shall be included in the cost of Elastomeric Bearing Assembly, Type II.

The 1/8" PTFE sheet shall be bonded directly to the top steel plate with a two-component, medium viscosity epoxy resin, conforming to the requirements of the Federal Specification MMM-A-134, Type I. The bond agent shall be applied on the full area of the contact surfaces.

Bonding of 1/8" PTFE sheet during vulcanizing process will be permitted provided the process and method of adjusting assembly height is approved by the Engineer.

The structural steel plates of the Bearing Assembly shall conform to the requirements of AASHTO M 270 Grade 50. Two 1/8 in. adjusting shims shall be provided for each bearing in addition to all other plates or shims and placed as shown on bearing details.

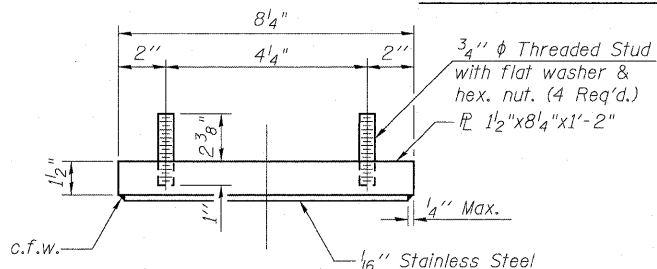

TOP BEARING ASSEMBLY

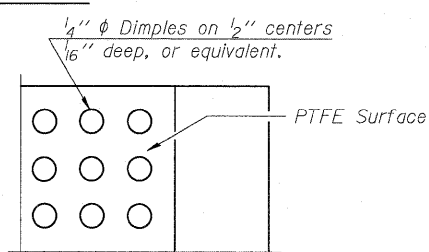

PLAN-PTFE SURFACE

SHIM "t" DIMENSIONS

Location	"t"
Beam 1	-
Beam 2	5/8"
Beam 3	-
Beam 4	5/8"
Beam 5	-
Beam 6	5/8"
Beam 7	5/8"
Beam 8	-
Beam 9	5/8"
Beam 10	-
Beam 11	5/8"
Beam 12	-

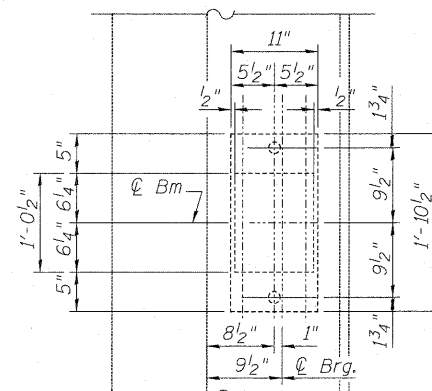

EXISTING BEARING PLAN

\* Burn existing Anchor Bolts flush with concrete removal line. Cost included with Jack and Remove Existing Bearing

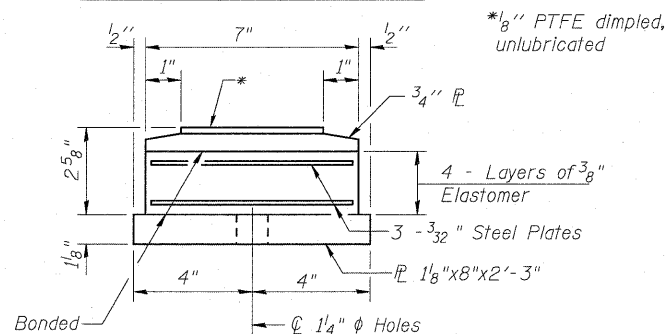

BOTTOM BEARING ASSEMBLY

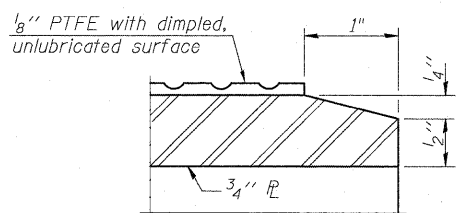

SECTION THRU PTFE

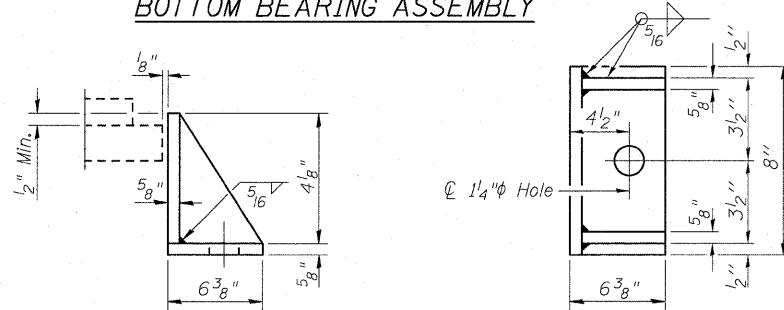

SIDE RETAINER

Equivalent rolled angle with stiffeners will be allowed in lieu of welded plates.

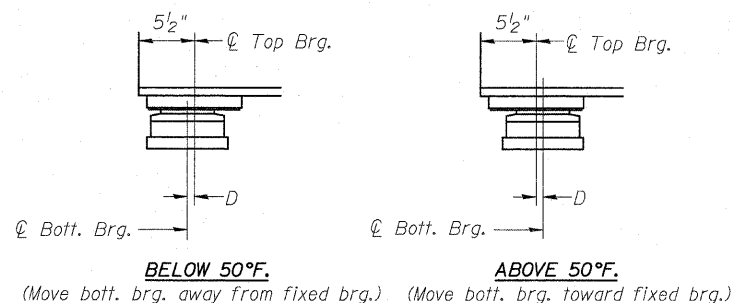

SETTING ANCHOR BOLTS AT EXP. BRG.

D=1/8" per each 100' of expansion for every 15° temp. change from the normal temp. of 50°F.

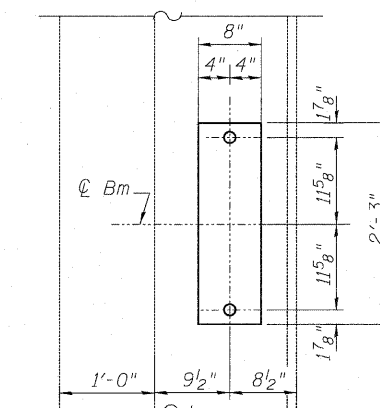

PROPOSED BEARING PLAN

BILL OF MATERIAL

Item	Unit	Total
Elastomeric Bearing Assembly, Type II	Each	12
Anchor Bolts, 1"	Each	24
Jacking and Cribbing	Each	12

ELASTOMERIC BEARING TYPE II DETAILS  
STRUCTURE NO. 016-0519

DESIGNED	JPM
CHECKED	TG
DRAWN	MPS
CHECKED	JPM, TG



180 S. WACKER DRIVE, SUITE 700, CHICAGO, IL 60606, P.312-606-0910 F.312-606-0415

LEGEND

Denotes concrete removal Billed in Abutment modification and Repair Details

SHEET NO.	F.A.U. RTE.	SECTION	COUNTY	TOTAL SHEETS	SHEET NO.
S22	1548	461 (VB&VF) I	COOK	52	34
S34 SHEETS			CONTRACT NO. 60H65		
DATE: 06-22-2010		ILLINOIS FED. AID PROJECT			