

### OPEN DITCH INSTALLATION

**NOTES:**

- 1) **FOUNDATION:** WHERE THE TRENCH BOTTOM IS UNSTABLE, THE CONTRACTOR SHALL EXCAVATE TO A DEPTH REQUIRED BY THE ENGINEER. THIS WORK SHALL BE PAID FOR AS UNDERCUT UNSUITABLE MATERIAL (SEE SPECIAL PROVISIONS).
- 2) **BEDDING:** 4" OF GRANULAR MATERIAL MEETING THE REQUIREMENTS OF SECTION 208 (TRENCH BACKFILL) SHALL BE USED FOR BEDDING. THIS WORK SHALL BE INCIDENTAL TO THE STORM SEWER, TYPE B (SEE SPECIAL PROVISIONS FOR STORM SEWER, CLASS B).
- 3) **HAUNCHING AND INITIAL BACKFILL:** MATERIAL MEETING THE REQUIREMENTS OF SECTION 208 (TRENCH BACKFILL) SHALL BE USED. THIS WORK SHALL BE INCIDENTAL TO THE STORM SEWER, TYPE B.
- 4) UNLESS OTHERWISE SPECIFIED BY THE ENGINEER, MINIMUM TRENCH WIDTHS SHALL BE AS FOLLOWS:

NOMINAL DIA. IN	MIN RECOMMENDED TRENCH WIDTH, IN
4	21
6	23
8	25
10	28
12	31
15	34
18	39
24	48
30	66
36	78
42	83
48	89
60	102

5) **MINIMUM COVER:** MINIMUM RECOMMENDED DEPTHS OF COVER FOR VARIOUS LIVE LOADING CONDITIONS ARE SUMMARIZED IN THE FOLLOWING TABLE. UNLESS OTHERWISE NOTED, ALL DIMENSIONS ARE TAKEN FROM THE TOP OF PIPE TO THE GROUND SURFACE.

SURFACE LIVE LOADING CONDITION	MINIMUM RECOMMENDED COVER, IN
H25 (FLEXIBLE PAVEMENT)	12 (24 FOR 60" PIPE)
H25 (RIGID PAVEMENT)	12 (24 FOR 60" PIPE)
E30 (RAILWAY)	24
HEAVY CONSTRUCTION	48

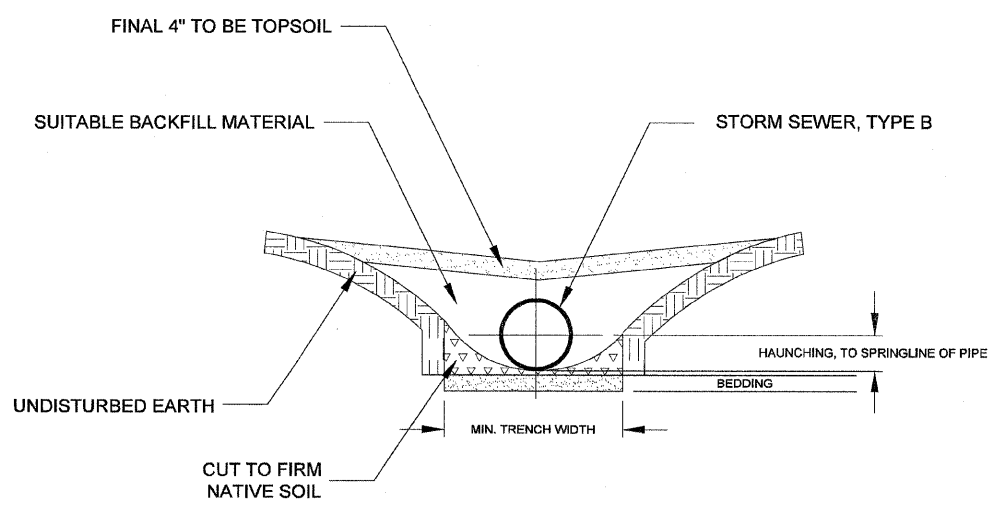

OPEN DITCH INSTALLATION  
TYPICAL CROSS-SECTION