

F.A.I. RTE.	SECTION	COUNTY	TOTAL SHEETS	SHEET NO.
94	1516.1 I-9	COOK	59	30
STA. 117+38.11 (SB I-57) TO STA. 154+09.94 (SB I-57)				
STA. 218+25.72 (NB I-57)				
FED. ROAD DIST. NO.	ILLINOIS	FED. AID PROJECT	62977	

NOTE:
THIS OPTION SHALL BE USED WHEN THE CARRIAGE WALK AREA MEASURES LESS THAN 12" IN WIDTH

NOTE:
THIS OPTION SHALL BE USED WHEN THE CARRIAGE WALK AREA MEASURES 12" TO 18" IN WIDTH

NOTE:
THIS OPTION SHALL BE USED WHEN THE CARRIAGE WALK AREA MEASURES 18" OR GREATER IN WIDTH

VARIES PANEL:
• IF THE WIDTH IS $\geq 4"$ THEN APPLY BROOM FINISH FLUSH TO THE KNEE WALL WITH 4" CALIFORNIA JOINT
• IF THE WIDTH IS $< 4"$ THEN SURFACE TO BE HARD TROWELLED (SEE DETAIL A)

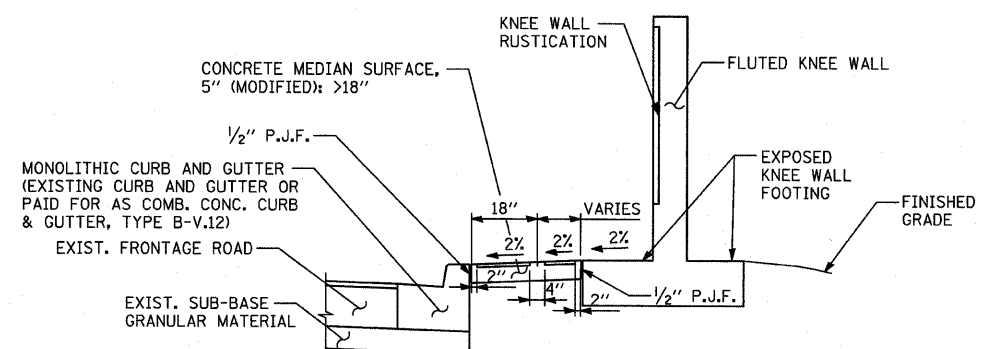
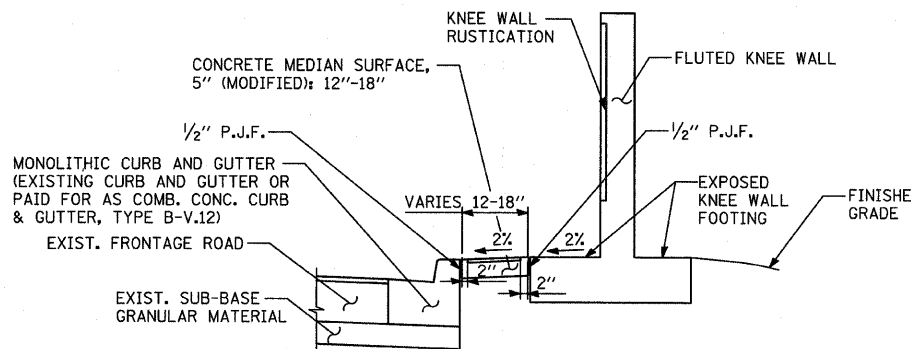
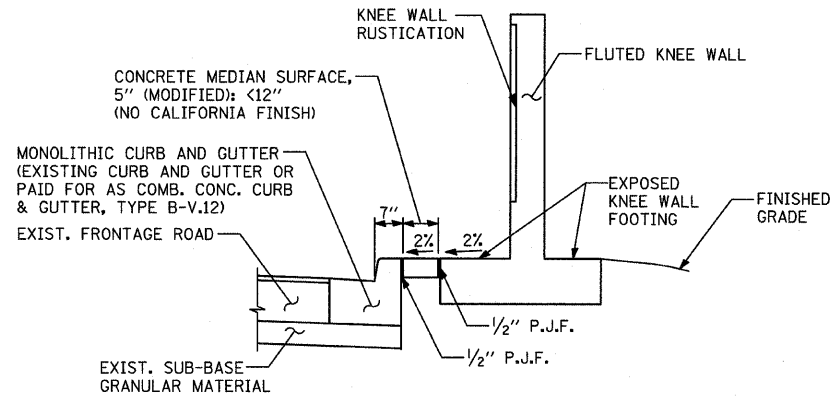
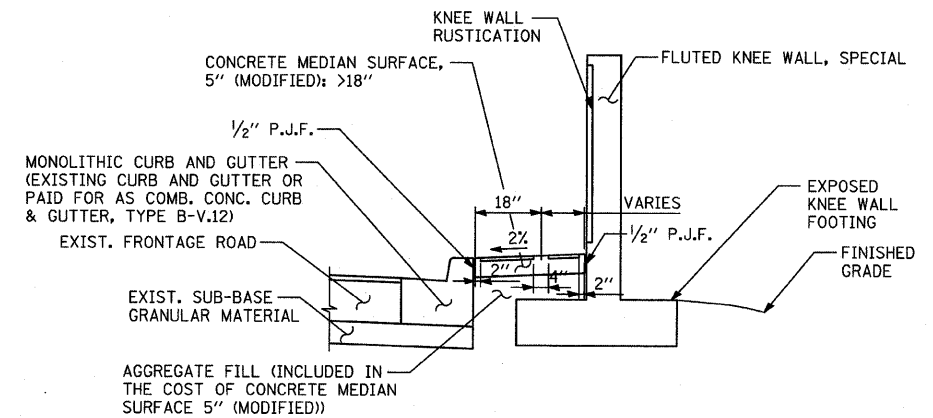
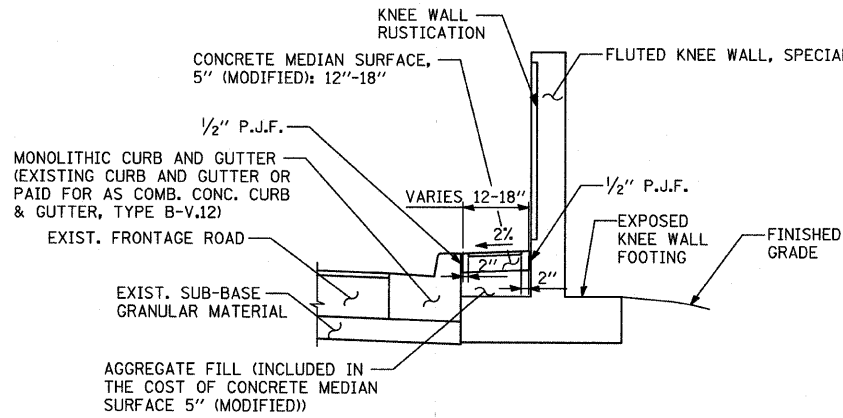
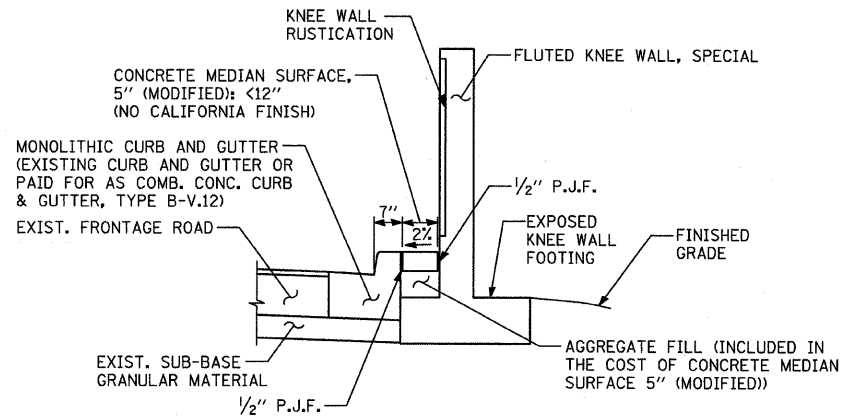

CONCRETE MEDIAN SURFACE, 5" (MODIFIED) "A"
AREA $< 12"$ WIDE

CONCRETE MEDIAN SURFACE, 5" (MODIFIED) "B"
AREA $12"-18"$ WIDE

CONCRETE MEDIAN SURFACE, 5" (MODIFIED) "C"
AREA $> 18"$ WIDE

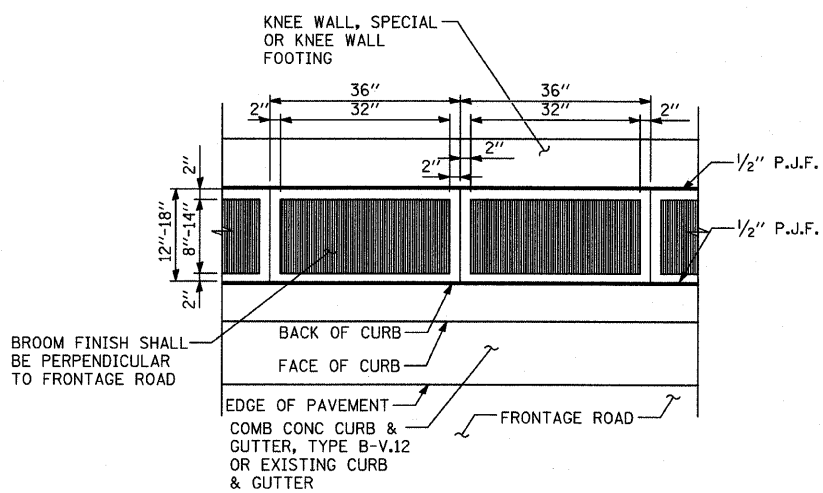

DETAIL "B": COORDINATE WITH CONC. MED. SURFACE, 5" (MODIFIED) "B"
CALIFORNIA FINISH

VARIES PANEL:
• IF THE WIDTH IS $\geq 4"$ THEN APPLY BROOM FINISH FLUSH TO THE KNEE WALL FACE WITH 4" CALIFORNIA JOINT
• IF THE WIDTH IS $< 4"$ THEN SURFACE TO BE HARD TROWELLED

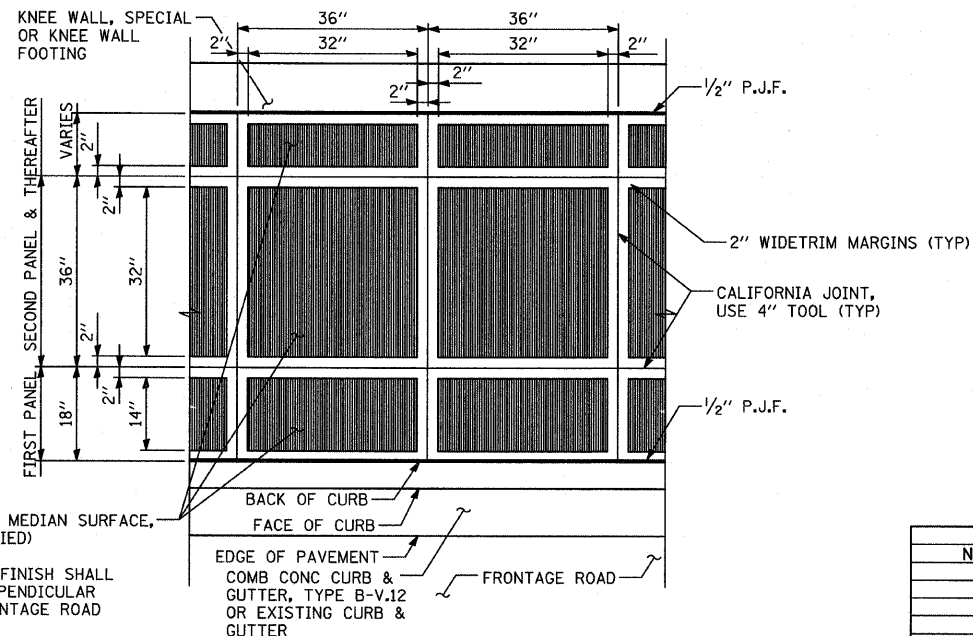

DETAIL "A": COORDINATE WITH CONC. MED. SURFACE, 5" (MODIFIED) "C"
CALIFORNIA FINISH

NOTE:
NOT ALL ITEMS SHOWN ON THIS SHEET ARE PROPOSED. SEE PLANS FOR PROPOSED ITEMS.

REVISIONS	
NAME	DATE

ILLINOIS DEPARTMENT OF TRANSPORTATION
F.A.I. 94 (DAN RYAN EXPRESSWAY)
CONCRETE MEDIAN SURFACE, 5" (MODIFIED) WITH CALIFORNIA FINISH DETAIL
SCALE: NONE
DATE: JANUARY 16, 2009
DRAWN BY: MPG
CHECKED BY: JPM